

BAB VI

KESIMPULAN DAN SARAN

6.1 Kesimpulan

Berdasarkan pengujian yang telah dilakukan pada balok *Self Compacting Concrete* dengan Serat *Polypropylene* dan Bahan Tambah *Silica fume* dapat ditarik kesimpulan sebagai berikut :

1. Berat jenis beton rerata yang didapatkan dari masing-masing benda uji yaitu untuk umur 7 hari BN sebesar 2417.649 kg/m^3 , BS sebesar 2320.391 kg/m^3 ; untuk umur 14 hari BN sebesar 2461.91 kg/m^3 , BS sebesar 2372.852 kg/m^3 ; untuk umur 28 hari BN sebesar 2410.179 kg/m^3 , BS sebesar 2352.412 kg/m^3 . Dari hasil yang didapat maka dapat disimpulkan bahwa berat jenis dari tiap variasi masih tergolong beton non serat.
2. Kuat tekan beton rerata yang didapatkan dari masing-masing benda uji yaitu untuk umur 7 hari BN sebesar 44.646 MPa , BS sebesar 25.149 MPa ; untuk umur 14 hari BN sebesar 46.8295 MPa , BS sebesar 30.344 MPa ; untuk umur 28 hari BN sebesar 49.899 MPa , BS sebesar 35.482 MPa .
3. Kuat tarik belah beton rerata yang didapatkan dari masing-masing benda uji yaitu untuk umur 7 hari BN sebesar 3.727 MPa , BS sebesar 2.397 MPa ; untuk umur 14 hari BN sebesar 3.877 MPa , BS sebesar 3.556 MPa ; untuk umur 28 hari BN sebesar 4.350 MPa , BS sebesar 4.465 MPa .
4. Modulus elastisitas beton rerata yang didapatkan dari masing-masing benda uji yaitu untuk umur 7 hari BN sebesar 20958.7182 MPa , BS sebesar 14851.3983 MPa ; untuk umur 14 hari BN sebesar 27151.5948 MPa , BS sebesar

20564.8757 MPa; untuk umur 28 hari BN sebesar 19961.8818 MPa, BS sebesar 25680.4728 MPa.

5. Modulus of Rupture rerata yang didapatkan dari masing-masing benda uji yaitu untuk umur 7 hari BN sebesar 3.7209 MPa , BS sebesar 3.4497 MPa; untuk umur 14 hari BN sebesar 4.1670 MPa, BS sebesar 3.8897 MPa; untuk umur 28 hari BN sebesar 4.7007 MPa, BS sebesar 4.8260 MPa.
6. Kapasitas balok untuk masing-masing benda uji yaitu BN 1 Shear sebesar 62.75 kN dan BN 2 Shear sebesar 63.44 kN sehingga didapatkan kapasitas rerata untuk BN Shear yaitu 63.095 kN, BS 1 Shear sebesar 60.76 kN dan BS 2 Shear sebesar 50.60 kN sehingga didapatkan kapasitas rerata untuk BS Shear yaitu 55.68 kN.
7. Beban retak pertama pada masing-masing benda uji adalah BN 1 Shear sebesar 27.58 kN dan BN 2 Shear sebesar 24.85 kN sehingga didapatkan beban retak pertama rerata untuk BN Shear yaitu 26.215 kN, BS 1 Shear sebesar 26.95 kN dan BS 2 Shear sebesar 18.92 kN sehingga didapatkan beban retak pertama rerata untuk BS Shear yaitu 22.935 kN.
8. Berdasarkan beberapa pengujian yang telah dilakukan , penggunaan serat sebanyak 0.6 tidak banyak berpengaruh terhadap benda uji, pada umur 28 hari untuk kuat tarik belah, modulus elastis, dan *modulus of rupture* beton lebih tinggi dari beton serat, akan tetapi untuk kuat tekan dan kapasitas geser pada balok pada umur 28 hari kurang dari beton non serat yang tidak menggunakan serat.

6.2 Saran

Saran yang dapat penulis berikan setelah melihat penelitian ini adalah sebagai berikut :

1. Perlu penelitian lebih lanjut mengenai penambahan serat pada balok dalam jumlah variasi yang lebih banyak sehingga bisa didapatkan komposisi yang optimum untuk diterapkan pada benda uji balok.
2. Penelitian selanjutnya sebaiknya memperhatikan proses pencampuran bahan-bahan dan saat proses *mixing* perlu diperhatikan agar tidak ada yang terbuang dan perbedaan antar spesimen tidak terlalu jauh.
3. Perlu disediakan alat bantu dalam mendeteksi retakan agar pada saat terjadi retak pertama tidak terjadi kesalahan dari faktor manusia, sehingga didapatkan hasil yang lebih akurat.

DAFTAR PUSTAKA

- As'ad, S., *Beton Memadat Mandiri*, JOGLOSEMAR, Agustus 2012.
- Asmara, P. Y., 2016, Pengaruh Variasi Kadar *Silica fume* terhadap sifat Mekanik *Self Compacting Fibre Reinforced Concrete (SCFRC)*, Laporan Penelitian Tugas Akhir Universitas Atma Jaya Yogyakarta, Yogyakarta.
- ASTM C.78, 1996, *Concrete and Aggregates*, Annual Book of ASTM Standards, vol. 04.02, USA.
- EFNARC, BIBM, CEMBUREAU, EFCA, ERMCO, 2005, *The European Guidelines for Self-Compacting Concrete*.
- Iqbal, M., Sumajouw, M.D.J., Windah, R. S., Imbar, S. E.J., *Pengujian Geser Balok Beton Bertulang Dengan Menggunakan Sengkok Konvensional*, Jurnal Sipil Statik Vol.1 no.2, Januari 2013 (65-69).
- Mariani, Sampebulu, V., Ahmad, A.G., *Pengaruh Penambahan Admixture terhadap Karakteristik Self Compacting Concrete*, Jurnal SMARTek vol. 7 no. 3 Agustus 2009.
- Mukti, D. K., 2016, *Pengaruh High Volume Fly ash Concrete Substitusi Agregat Halus Terhadap Kuat Geser Balok*, Laporan Penelitian Tugas Akhir Universitas Atma Jaya Yogyakarta, Yogyakarta.
- Nardo, L., *Studi Pengaruh Penambahan Fiber Lokal Terhadap Kuat Geser Balok Beton Memadat Mandiri*, Laporan Penelitian Tugas Akhir Universitas Atma Jaya Yogyakarta, Yogyakarta.
- Widodo, S., *Kapasitas Geser Interface antara Beton Ringan Berserat sebagai stay-in place form work dengan self-compacting concrete topping untuk konstruksi pelat lantai komposit*, November 2013.
- Tjaronge, M.W., Irnawaty, R., Chandra, E., Limpo, A., *Slump flow dan Kuat Lentur Self Compacting Concrete (SCC) dengan kandungan superplasticizer yang bervariasi*, Media Teknik Sipil, Januari 2006.
- Wibawa, T. K., *Silica fume (SF) Untuk Beton*, dalam situsnya <http://tatangw.blogspot.co.id/2011/04/silikafume-sf-untuk-beton.html> , 30 April 2011.
- Widodo, S., 2008, Uji Karakteristik Beton Segar Akibat Penambahan Serat *Polypropylene* Dalam Adukan Self-Consolidating Concrete, *Prosiding Seminar Nasional Aplikasi Teknologi Prasarana Perkotaan*, ISBN 978- 979-18342-0-9, B-154.



UNIVERSITAS ATMA JAYA YOGYAKARTA
Fakultas Teknik Program Studi Teknik Sipil
Laboratorium Transportasi

Jl. Babarsari No.44 Yogyakarta 55281 Indonesia Kotak Pos 1086
 Telp. +62-274-487711 (hunting) Fax. +62-274-487748

Lampiran 1
 Halaman 88

Lampiran Surat/Laporan No. : Dikerjakan :
 Pekerjaan : Diperiksa :
 Tgl. Pemeriksaan :

**PEMERIKSAAN KEAUSAN AGREGAT
 DENGAN MESIN LOS ANGELES**

GRADASI SARINGAN		NOMOR CONTOH	
		I	II
LOLOS	TERTAHAN	BERAT MASING- MASING AGREGAT	BERAT MASING- MASING AGREGAT
3/8"	1/4"	2500	-
1/4"	No. 4	2500	-

NOMOR CONTOH	I
BERAT SEBELUMNYA (A)	5000 gram
BERAT SESUDAH DIYAK SARINGAN NO.12 (B)	3784 gram
BERAT SESUDAH (A)-(B)	1216 gram
KEAUSAN = $\frac{(A)-(B)}{(A)} \times 100\%$	24.32 %

UKURAN SARINGAN		BERAT AGREGAT			
LOLOS	TERTAHAN	A	B	C	D
1 1/2"	1"	1250			
1"	3/4"	1250			
3/4"	1/2"	1250	2500		
1/2"	3/8"	1250	2500		
3/8"	1/4"			2500	
1/4"	No. 4			2500	
No. 4	No. 8				5000
TOTAL		5000	5000	5000	5000
JUMLAH BOLA BAJA		12	11	8	6



UNIVERSITAS ATMA JAYA YOGYAKARTA
Fakultas Teknik Program Studi Teknik Sipil
Laboratorium Transportasi

Jl. Babarsari No.44 Yogyakarta 55281 Indonesia Kotak Pos 1086
Telp. +62-274-487711 (hunting) Fax. +62-274-487748

Lampiran 1
Halaman 89

Laporan No. : Dikerjakan :
Pekerjaan : Diperiksa :
..... Tgl. Pemeriksaan :

ANALISIS SARINGAN AGREGAT KASAR

BERAT KERING : 1000 gram						
Nomor Saringan	B.Saringan (gram)	Berat Saringan + Tertahan (gram)	B.Tertahan (gram)	Σ B.Tertahan (gram)	Persentase	
					B.Tertahan %	Lolos %
3/4" (19,1 mm)	573	573	0	0	0	100
1/2" (12,7 mm)	453	483	30	30	3	97
3/8" (9,52mm)	459	673	214	244	24	76
No.4(4,75 mm)	531	1087	556	800	80	20
No.8(2,36 mm)	327	493	166	966	97	3
No.30(0,60mm)	293	307	14	980	98	2
No.50(0,30mm)	376	381	5	985	99	1
No.100(0,15mm)	352	356	5	990	99	1
No.200(0,75mm)	337	341	4	994	99	1
PAN	375	381	6	1000	100	0

$$\text{MHB Agregat Kasar} = \frac{5988}{1000} = 5.988$$



UNIVERSITAS ATMA JAYA YOGYAKARTA
Fakultas Teknik Program Studi Teknik Sipil
Laboratorium Transportasi

Jl. Babarsari No.44 Yogyakarta 55281 Indonesia Kotak Pos 1086
Telp. +62-274-487711 (hunting) Fax. +62-274-487748

Lampiran 2
Halaman 90

Laporan No. : Dikerjakan :
Pekerjaan : Diperiksa :
..... Tgl. Pemeriksaan :

ANALISIS SARINGAN AGREGAT HALUS

BERAT KERING: 1000 gram						
Nomor Saringan	B.Saringan (gram)	Berat Saringan + Tertahan (gram)	B.Tertahan (gram)	Σ B.Tertahan (gram)	Persentase	
					B.Tertahan %	Lolos %
3/4" (19,1 mm)	573	573	0	0	0.0	100.0
1/2" (12,7 mm)	453	453	0	0	0.0	100.0
3/8" (9,52 mm)	459	461	3	3	0.3	99.7
No.4(4,75 mm)	531	533	2	5	0.5	99.5
No.8(2,36 mm)	327	329	2	7	0.7	99.3
No.30(0,60 mm)	293	766	473	480	48.0	52.0
No.50(0,30 mm)	376	619	243	724	72.4	27.6
No.100(0,15 mm)	352	500	148	872	87.2	12.8
No.200(0,75 mm)	241	355	114	986	98.6	1.4
PAN	375	389	14	1000	100.0	0.0

Masuk Gradasi Pasir No. 2 (Sedang)

$$\text{MHB Agregat Halus} = \frac{3077}{1000} = 3.077$$



PEMERIKSAAN KANDUNGAN LUMPUR AGREGAT HALUS

- A. Waktu pemeriksaan : 20 September 2016
- B. Bahan
- Pasir kering tungku, asal : Kali Progo, berat : 100 gram
 - Air jernih asal : LSBB Prodi TS FT-UAJY
- C. Alat
- Gelas ukur, ukuran: 250 cc
 - Timbangan
 - Tungku (oven), suhu antara 105-110°C
 - Pasir + piring masuk tungku tanggal 20 September 2016 jam 09.00 WIB
- D. Hasil
- Pasir + piring keluar tungku tanggal 30 Maret 2016 jam 11.00 WIB
- Berat pasir = 100 gram
 - Berat pasir kering oven = 97.1925 gram

$$\text{Kandungan Lumpur} = \frac{100 - 97.1925}{100} \times 100\% = 2.8075\%$$

Kesimpulan: Kandungan lumpur 2.8075% < 5%, syarat terpenuhi (OK)



PEMERIKSAAN KANDUNGAN ZAT ORGANIK AGREGAT HALUS

- A. Waktu pemeriksaan : 20 September 2016
- B. Bahan
- a. Pasir kering tungku, asal : Kali Progo, berat : 120 gram
- b. Larutan NaOH 3%
- C. Alat
- Gelas ukur, ukuran : 250 cc
- D. Sketsa

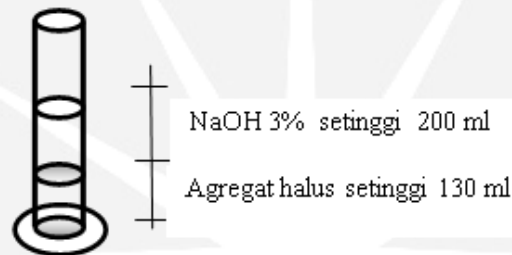

- E. Hasil
- Setelah didiamkan selama 24 jam, warna larutan di atas pasir sesuai dengan warna Gardner Standard Color sesuai dengan No. 8.

Kesimpulan: Warna Gardner Standard Color No. 8 yaitu kuning muda, maka syarat terpenuhi (OK)



PERHITUNGAN *MIX DESIGN*

(SNI 02-2834-2000)

A. Data Bahan

1. Bahan agergat halus (pasir) : Kali Progo, Yogyakarta
2. Bahan agregat kasar : Clereng, Yogyakarta
3. Jenis semen : Semen PPC merk Gresik

B. Data *Specific Gravity*

1. *Specific Gravity* agregat halus (pasir) : 2,5253
2. *Specific Gravity* agregat kasar : 2,4405

C. Hitungan

1. Kuat tekan beton yang disyaratkan (f'_c) pada umur 28 hari. $F'_c = 40$ MPa.
2. Menentukan nilai devisiasi standar berdasarkan tingkat mutu pengendalian pelaksanaan campuran.
3. Nilai margin ditentukan sebesar 12 MPa.
4. Menetapkan kuat tekan beton rata-rata yang direncanakan berdasarkan SNI butir

4.2.3.1 3.

$$f'_c = f_c + M = 40 + 12 = 52 \text{ MPa.}$$

5. Menentukan jenis semen. Jenis semen PPC dengan merk Gresik.
6. Menetapkan jenis agregat
 - a. Agregat halus : Pasir alam (Golongan 2)
 - b. Agregat kasar : Batu Pecah



7. Menetapkan faktor air-semen. Berdasarkan tipe semen dan kuat tekan rata-rata silinder beton yang direncanakan pada umur tertentu. Faktor air-semen direncanakan sebesar 0,42.
8. Menetapkan faktor air-semen maksimum.

Persyaratan Jumlah Semen Minimum dan Faktor Air Semen Maksimum Untuk Berbagai Macam Pembetonan dalam Lingkungan Khusus

Lokasi	Jumlah Semen Minimum Per m³ Beton (kg)	Nilai Faktor Air Semen Maksimum
Beton di dalam ruang bangunan : a. Keadaan keliling non-korosif	275	0,6
b. Keadaan keliling korosif disebabkan oleh kondensasi atau uap korosif	325	0,52
Beton diluar ruangan bangunan : a. tidak terlindung dari hujan dan terik matahari langsung	325	0,60
b. terlindung dari hujan dan terik matahari langsung	275	0,60
Beton masuk kedalam tanah : a. mengalami keadaan basah dan kering berganti-ganti	325	0,55
b. mendapat pengaruh sulfat dan alkali dari tanah		Lihat Tabel 5
Beton yang kontinu berhubungan: a. Air tawar		Lihat Tabel 6
b. Air laut		

(Sumber : SNI 03-2834-2000 : Tabel 4)

Berdasarkan Tabel 4 SNI 03-2834-2000, untuk beton dalam ruang bangunan sekeliling non-korosif, fas maksimum adalah 0,6. Fas maksimum dibandingkan dengan langkah No.7 kemudian dipakai yang terkecil. Maka digunakan fas 0,42.

9. Menetapkan nilai *slump*. Nilai *slump* direncanakan 60-180 mm.



10. Ukuran butiran maksimum (krikil) adalah 10 mm.

11. Menetapkan jumlah air yang diperlukan tiap m³ beton.

- Ukuran butir maksimum 10 mm.
- Nilai *slump* 60-180 mm.
- Agregat halus berupa batu tak dipecah, maka $W_h = 225$
- Agregat kasar berupa batu pecah, maka $W_k = 250$

$$W = \frac{2}{3}W_h + \frac{1}{3}W_k$$

Dengan : W_h = Perkiraan jumlah air untuk agregat halus

W_k = Perkiraan jumlah air untuk agregat kasar

$$W = \frac{2}{3} \times 225 + \frac{1}{3} \times 250 = 233,333 \text{ liter}$$

12. Menghitung berat semen yang diperlukan :

a. Berdasarkan Tabel 4 SNI 03-2834-2000, didapat semen minimum 275 kg.

b. Berdasarkan $f_{as} = 0.42$. Semen per m³ beton = $\frac{A}{f_{as}} = \frac{233,25}{0,42}$

$$= 555,556 \text{ kg}$$

Dipilih berat semen paling besar. Maka digunakan berat semen 555,556 kg.

13. Penyesuaian jumlah air atau f_{as} .

$$f_{as} \text{ rencana} = 0,42$$

$$f_{as} \text{ maks} > f_{as} \text{ rencana}$$

$$0,6 > 0,42 \dots\dots\dots \text{OK!}$$

14. Perbandingan agregat halus dan kasar

- Ukuran maksimum agregat 10 mm.



- b. Nilai *slump* 60 – 180 mm.
- c. *fas* 0,42.
- d. Jenis gradasi pasir No. 2.

Persentase penggunaan agregat halus = 45,5 %

15. Berat jenis agregat campuran :

$$= \frac{P}{100} \times B_j \text{ agregat halus} + \frac{K}{100} \times B_j \text{ agregat kasar}$$
$$= 2,479$$

Keterangan :

P = % agregat halus terhadap agregat campuran

K = % agregat kasar terhadap agregat campuran

16. Diperoleh berat jenis beton adalah 2225 kg/m³

17. Berat agregat campuran

= berat tiap m³ – keperluan air dan semen

$$= 1436,111 \text{ kg/m}^3$$

18. Menghitung berat agregat halus

Berat agregat halus = % berat agregat halus x keperluan agregat campuran

$$= 653,431 \text{ kg/m}^3$$

19. Menghitung berat agregat kasar

Berat agregat kasar = % berat agregat kasar x keperluan agregat campuran

$$= 782,681 \text{ kg/m}^3$$



PERENCANAAN TULANGAN BALOK BETON

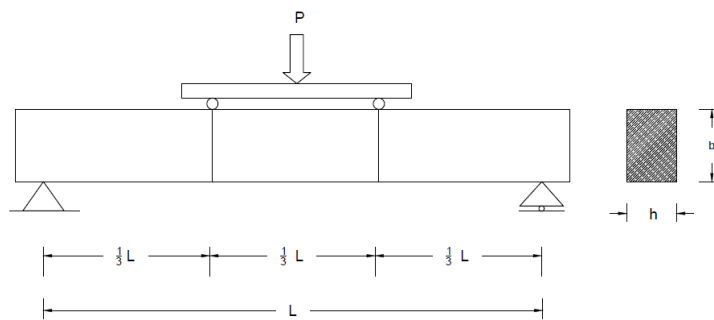
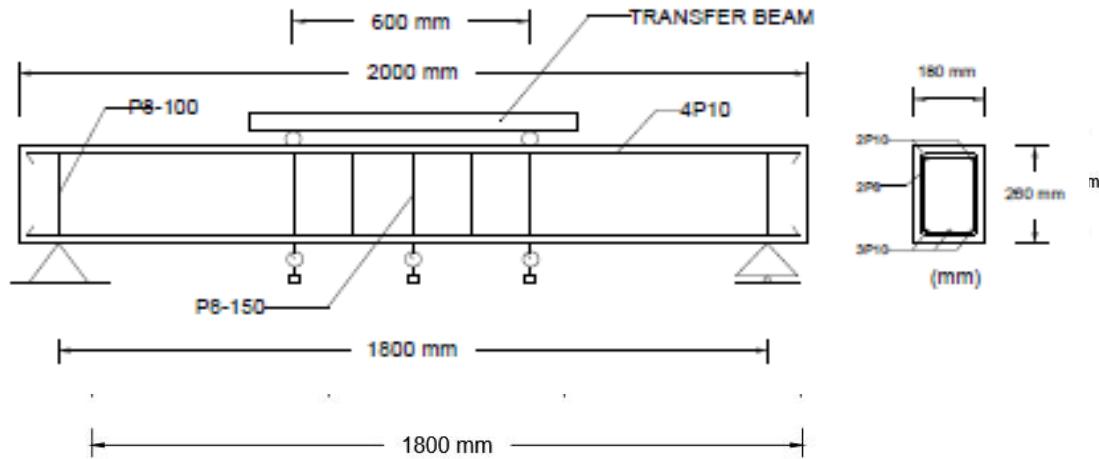

SFD

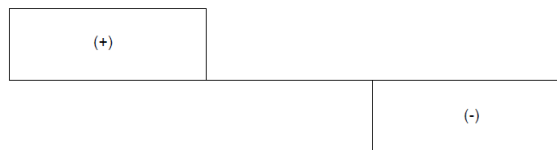

BMD

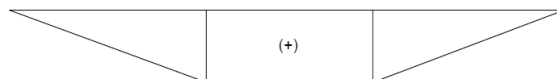

Berat sendiri balok diabaikan



A. Data Bahan

Lebar balok (bw)	= 180 mm
Tinggi balok (h)	= 260 mm
f_c	= 40 MPa
f_y	= 240 MPa
Diameter tulangan tarik	= polos 10 mm (P10)
Diameter tulangan geser	= polos 8 mm (P8)
Selimit beton	= 20 mm
Berat volume beton	= 24 kN/m ³
Beban rencana (P)	= 5 ton
Jarak tumpuan ke beban	= 600 mm = 0.6 m

B. Perhitungan Beban

$$\begin{aligned} \text{Jarak efektif (d)} &= H - \text{selimit} - \text{tulangan geser} - \frac{1}{2} \text{tulangan Longitudinal} \\ &= 260 - 20 - 8 - \frac{1}{2} \times 10 \\ &= 227 \text{ mm} \end{aligned}$$

Beban 5 ton didistribusikan menggunakan transfer beam yang kemudian dianggap beban pada kedua titik masing-masing 2.5 ton

$$\begin{aligned} \text{Mu lapangan} &= \frac{1}{2} P \times D = \frac{1}{2} \times 50 \times 0.6 \\ &= 15 \text{ kN} \end{aligned}$$

$$\text{Vu tumpuan} = 25 \text{ kN}$$



C. Rencana tulangan lapangan

$$R_n \text{ perlu} = \frac{M_u}{0.8 \times b \times d}$$

- $R_n \text{ perlu} = \frac{15 \times 1000}{0.8 \times 180 \times 227} = 0.4588839941 \text{ MPa}$

$$\rho \text{ perlu} = 0.85 \times \frac{f'_c}{f_y} \times \left(1 - \sqrt{1 - \frac{2R_n}{0.85 \times f'_c}} \right)$$

- $\rho \text{ perlu} = 0.85 \times \frac{40}{240} \times \left(1 - \sqrt{1 - \frac{2(1.3767)}{0.85 \times 40}} \right)$
 $= 0.00080127804$

$$\rho \text{ min} = \frac{1.4}{f_y}$$

- $\rho \text{ min} = \frac{1.4}{f_y} = 0.0058333333$

$$\rho \text{ max} = 0.75 \times \rho_b = 0.75 \times \left(0.85 \times \frac{f'_c \times \beta}{f_y} \times \frac{600}{600 + f_y} \right)$$

- $\rho \text{ max} = 0.75 \times \left(0.85 \times \frac{40 \times 0.85}{240} \times \frac{600}{600 + 240} \right)$
 $= 0.06450892857$

$$\rho \text{ min} < \rho \text{ perlu} < \rho \text{ max}$$

- dipakai $\rho = 0.0058333333$

$$A_s \text{ perlu} = \rho \times b_w \times d$$

- $A_s \text{ perlu} = 0.0058333333 \times 180 \times 227$
 $= 238.3499999 \text{ mm}^2$

- $\text{Luas P10} = \frac{1}{4} \times \pi \times \text{diameter}^2 = \frac{1}{4} \times \pi \times 10^2$
 $= 78.53981634 \text{ mm}^2$

$$\text{Jumlah Tulangan (n)} = \frac{A_s \text{ perlu}}{A_s \text{ tulangan}}$$



- Jumlah tulangan = 3.034766453 = 3 buah
- Digunakan = 3P10

D. Rencana tulangan geser

- Diketahui $V_u = 25$ kN

$$V_n = \frac{V_u}{\phi}$$

- $V_n = \frac{25}{0.75} = 33.33333$ kN

$$V_c = \frac{1}{6} \times \sqrt{f'_c} \times b_w \times d$$

- $V_c = \frac{1}{6} \times \sqrt{40} \times 180 \times 227$
 $= 43.07022173$ kN

$V_c > V_n$, secara teoritis tidak membutuhkan tulangan geser

Karena tidak memerlukan tulangan geser, maka dipakai jarak tulangan geser 2P8-100 untuk daerah tumpuan dan 2P8-150 untuk daerah lapangan.



PEMERIKSAAN TULANGAN BAJA

PENGUJIAN KUAT TARIK BAJA

Kode Baja	Diameter (mm)	Tegangan Leleh (fy) kgf	Tegangan Ultimate (fu) kgf
BJTP 10 - A	10,56	3120	4180
BJTP 10 - B	10,75	3150	4190
BJTP 10 - C	10,58	3220	4320
BJTP 8 - A	7,98	2250	3120
BJTP 8 - B	7,98	2260	3120
BJTP 8 - C	7,98	2265	3125

Contoh perhitungan BJTP 10 – A :

$$\text{Diameter baja (d)} = 10,56 \text{ mm}$$

$$\text{Tegangan leleh (fy)} = 3120 \text{ kgf}$$

$$\text{Tegangan ultimate (fu)} = 4180 \text{ kgf}$$

$$\begin{aligned} \text{Luas tampang baja (A)} &= \frac{1}{4} \times \pi \times d^2 = \frac{1}{4} \times \pi \times 10,56^2 \\ &= 87,5826 \text{ mm}^2 \end{aligned}$$

$$\text{Tegangan leleh (fy)} = \frac{fy \times 9,81}{A} = \frac{3120 \times 9,81}{87,5826} = 349,4668 \text{ MPa}$$

$$\text{Tegangan ultimate (fu)} = \frac{fu \times 9,81}{A} = \frac{4180 \times 9,81}{87,5826} = 468,1595 \text{ Mpa}$$



HASIL PERHITUNGAN

Kode Baja	Tegangan Leleh (fy) MPa	Tegangan Leleh Rerata (fy) kgf	Tegangan Ultimate (fu) kgf	Tegangan Ultimate Rerata (fu) kgf
BJTP 10 - A	349.4668	349.7458	468.1959	467.706
BJTP 10 - B	340.4652		452.8728	
BJTP 10 - C	359.3053		482.0494	
BJTP 8 - A	441.3223	442.9568	611.9669	612.2938
BJTP 8 - B	443.2837		611.9669	
BJTP 8 - C	444.2644		612.9476	



PENGUJIAN BETON

JADWAL PENGUJIAN BETON

No.	Kode	Uji 7 Hari	Uji 14 Hari	Uji 28 Hari
1	BN	15 November 2016	22 November 2016	5 Desember 2016
2	BS	22 November 2016	28 November 2016	13 Desember 2016

PEMERIKSAAN BERAT JENIS BETON

Variasi	Kode	7 Hari			14 Hari			28 Hari		
		Diameter (cm)	Tinggi (cm)	Berat (kg)	Diameter (cm)	Tinggi (cm)	Berat (kg)	Diameter (cm)	Tinggi (cm)	Berat (kg)
BN	BN-1	14.99	30.14	12.74	15.01	30.18	13	15.01	30.24	13
	BN-2	14.95	29.91	12.82	14.88	30.18	13.12	15.46	30.02	12.98
	BN-3	15.08	29.79	12.86	14.92	30.40	13.02	14.84	30.05	12.98
BS	BS-1	15.04	29.84	12.54	14.92	29.29	12.5	14.97	30.37	12.50
	BS-2	14.98	29.94	12.56	15.04	30.15	12.42	15.07	30.713	12.78
	BS-3	15.06	30.14	11.9	14.96	30.26	12.54	15.09	30.28	12.85

Contoh perhitungan :

Beton BN-1 Umur 7 Hari :

- Berat silinder beton = 12,74 kg
- Diameter silinder beton (d) = 14,99 cm
- Tinggi silinder (t) = 30,14 cm
- Volume (V) = $\frac{1}{4} \times \pi \times d^2 \times t = \frac{1}{4} \times \pi \times 14,99^2 \times 30,14$
= 5319,078 cm³ = 5319,078 x 10⁻⁶ m³
- Berat jenis beton = $\frac{\text{berat}}{\text{volume}} = \frac{12,74}{5319,078 \times 10^{-6}}$
= 2394,836 kg/m³



TABEL BERAT JENIS BETON

Variasi	Kode Variasi	7 hari		14 hari		28 hari	
		Berat Jenis (Kg/m ³)	Berat Jenis Rerata (Kg/m ³)	Berat Jenis (Kg/m ³)	Berat Jenis Rerata (Kg/m ³)	Berat Jenis (Kg/m ³)	Berat Jenis Rerata (Kg/m ³)
BN	BN-1	2392.704	2417,649	2433.052	2461,910	2428,652	2410,179
	BN-2	2441.631		2501.304		2304,574	
	BN-3	2418.613		2451.375		2497,310	
BS	BS-1	2365.629	2320,391	2442.202	2372,852	2373.851	2352.412
	BS-2	2379.015		2318.466		2327.603	
	BS-3	2216.529		2357.889		2355.782	



PENGUJIAN KUAT TEKAN BETON

Contoh perhitungan :

BN – 1 umur 7 hari

$$P_{maks} = 765 \text{ KN} = 765000 \text{ N}$$

$$\begin{aligned} \text{Luas (A)} &= \frac{1}{4} \times \pi \times d^2 = \frac{1}{4} \times \pi \times 150,36^2 \\ &= 17756 \text{ mm}^2 \end{aligned}$$

$$f_c = \frac{P}{A} = \frac{400000}{17756} = 43,083 \text{ Mpa}$$

TABEL HASIL PERHITUNGAN KUAT TEKAN BETON

Variasi	Kode Variasi	7 hari		14 hari		28 hari	
		f _c (Mpa)	f _c Rerata (Mpa)	f _c (Mpa)	f _c Rerata (Mpa)	f _c (Mpa)	f _c Rerata (Mpa)
BN	BN-1	22.378*	44.646	34.644*	46.8295	45.962	49.899
	BN-2	43.083		43.645		49.025	
	BN-3	46.209		50.014		50.775	
BS	BS-1	25.743	25.149	29.610	30.344	34.717	35.482
	BS-2	25.531		29.802		35.020	
	BS-3	24.175		31.619		36.711	



PENGUJIAN KUAT TARIK BELAH BETON

Contoh perhitungan :

BN – 1 umur 7 hari

$$P_{maks} = 180 \text{ KN} = 18348.6239 \text{ kg}$$

$$\text{Luas selimut} = \pi dt = 1418.7863 \text{ cm}^2$$

$$f_c = \frac{2P}{\pi dt} = \frac{2 \times 18348.6239}{1418.7863} = 25.8652 \text{ kg/cm}^2 = 2.537 \text{ MPa}$$

TABEL HASIL PERHITUNGAN KUAT TARIK BELAH BETON

Variasi	Kode Variasi	7 hari		14 hari		28 hari	
		f _c (Mpa)	f _c Rerata (Mpa)	f _c (Mpa)	f _c Rerata (Mpa)	f _c (Mpa)	f _c Rerata (Mpa)
BN	BN-1	2.537	3.727	4.372	3.877	4.377	4.350
	BN-2	4.283		3.976		4.085	
	BN-3	3.171		3.282		4.588	
BS	BS-1	2.393	2.397	3.525	3.556	4.579	4.465
	BS-2	2.689		3.879		4.240	
	BS-3	2.110		3.265		4.576	



PENGUJIAN *MODULUS OF RUPTURE*

Contoh perhitungan :

BN – 1 umur 7 hari

- Lebar beton (b) = 200 mm
- Jarak antar tumpuan (L) = 600 mm
- Tinggi beton (d) = 200 mm
- Beban maksimum = 4.9 ton
= 4.9 x 1000 x 9.81 = 48069 N
- Kuat Lentur (R) = $\frac{P \times L}{b \times d^2} = \frac{48069 \times 600}{200 \times 200^2}$
= 3.605 MPa

TABEL HASIL PENGUJIAN *MODULUS OF RUPTURE*

Variasi	Kode Variasi	7 hari		14 hari		28 hari	
		Kuat Lentur (MPa)	Kuat Lentur Rerata (MPa)	Kuat Lentur (MPa)	Kuat Lentur Rerata (MPa)	Kuat Lentur (MPa)	Kuat Lentur Rerata (MPa)
BN	BBN-1	3.6052	3.7209	4.0613	4.1670	4.5992	4.6573
	BBN-2	3.9598		4.2526		4.6720	
	BBN-3	3.5978		4.1872		4.7007	
BS	BBS-1	3.1792	3.3450	3.9804	3.8897	4.7088	4.8260
	BBS-2	3.3558		3.9179		4.8479	
	BBS-3	3.4999		3.7707		4.9214	



PENGUJIAN MODULUS ELASTISITAS BETON

Contoh perhitungan :

BN-1 umur 7 hari

- Diameter silinder beton (d) = 14,9973 cm
- Beban (kgf) = 24500 kgf
- Perpendekan (0,5 ΔP) = 120,5 mm
- Panjang awal (P_0) = 20,201 cm
- Luas alas silinder beton (A) = $\frac{1}{4} \times \pi \times d^2 = \frac{1}{4} \times \pi \times 14,9973^2 \times 100$
= 17665,1761 cm²
- Tegangan (f) = $\frac{\text{beban} \times 9,81}{A} = \frac{24500 \times 9,81}{17665,1761}$
= 13,6056 MPa
- Regangan (ϵ) = $\frac{0,5 \Delta P}{P_0} = \frac{120,5 \times 0,001}{20,201 \times 10}$
= 5,9651 x 10⁻⁴
- Regangan koreksi (ϵ) = Regangan (ϵ) + koreksi
= 6,1938 x 10⁻⁴
- Modulus elastisitas (E_c) = $\frac{f}{\epsilon} = \frac{13,6056}{6,1938 \times 10^{-4}}$
= 21966.6264 Mpa



UNIVERSITAS ATMA JAYA YOGYAKARTA
Fakultas Teknik Program Studi Teknik Sipil
Laboratorium Struktur dan Bahan Bangunan

Jl. Babarsari No.44 Yogyakarta 55281 Indonesia Kotak Pos 1086
Telp.+62-274-487711 (hunting) Fax. +62-274-487748

Lampiran 10
Halaman 109

Silinder BN-1 (7 Hari)

$E_c = 21966.6264 \text{ Mpa}$

Beban	ΔP (mm)	0.5 ΔP (mm)	Tegangan (f) (MPa)	Regangan (ϵ) (10^{-4})	Regangan Koreksi (ϵ) (10^{-4})
0	0	0	0.0000	-0.2287	0.0000
500	1	0.5	0.2777	0.0248	0.2535
1000	3	1.5	0.5553	0.0743	0.3030
1500	7	3.5	0.8330	0.1733	0.4020
2000	11	5.5	1.1107	0.2723	0.5010
2500	15	7.5	1.3883	0.3713	0.6000
3000	19	9.5	1.6660	0.4703	0.6990
3500	24	12	1.9437	0.5940	0.8227
4000	29	14.5	2.2213	0.7178	0.9465
4500	33	16.5	2.4990	0.8168	1.0455
5000	38	19	2.7766	0.9405	1.1692
5500	43	21.5	3.0543	1.0643	1.2930
6000	48	24	3.3320	1.1881	1.4168
6500	53	26.5	3.6096	1.3118	1.5405
7000	58	29	3.8873	1.4356	1.6643
7500	64	32	4.1650	1.5841	1.8128
8000	69	34.5	4.4426	1.7078	1.9365
8500	75	37.5	4.7203	1.8563	2.0850
9000	81	40.5	4.9980	2.0049	2.2336
9500	86	43	5.2756	2.1286	2.3573
10000	92	46	5.5533	2.2771	2.5058
10500	97	48.5	5.8310	2.4009	2.6296
11000	103	51.5	6.1086	2.5494	2.7781
11500	109	54.5	6.3863	2.6979	2.9266
12000	114	57	6.6640	2.8216	3.0503
12500	119	59.5	6.9416	2.9454	3.1741
13000	123	61.5	7.2193	3.0444	3.2731
13500	127	63.5	7.4970	3.1434	3.3721
14000	130	65	7.7746	3.2177	3.4464
14500	134	67	8.0523	3.3167	3.5454
15000	139	69.5	8.3299	3.4404	3.6691
15500	143	71.5	8.6076	3.5394	3.7681
16000	153	76.5	8.8853	3.7869	4.0156



UNIVERSITAS ATMA JAYA YOGYAKARTA
Fakultas Teknik Program Studi Teknik Sipil
Laboratorium Struktur dan Bahan Bangunan

Jl. Babarsari No.44 Yogyakarta 55281 Indonesia Kotak Pos 1086
Telp. +62-274-487711 (hunting) Fax. +62-274-487748

Lampiran 10
Halaman 110

16500	158	79	9.1629	3.9107	4.1394
17000	162	81	9.4406	4.0097	4.2384
17500	166	83	9.7183	4.1087	4.3374
18000	171	85.5	9.9959	4.2325	4.4612
18500	176	88	10.2736	4.3562	4.5849
19000	181	90.5	10.5513	4.4800	4.7087
19500	186	93	10.8289	4.6037	4.8324
20000	190	95	11.1066	4.7027	4.9314
20500	195	97.5	11.3843	4.8265	5.0552
21000	201	100.5	11.6619	4.9750	5.2037
21500	206	103	11.9396	5.0988	5.3275
22000	212	106	12.2173	5.2473	5.4760
22500	217	108.5	12.4949	5.3710	5.5997
23000	221	110.5	12.7726	5.4700	5.6987
23500	228	114	13.0503	5.6433	5.8720
24000	234	117	13.3279	5.7918	6.0205
24500	241	120.5	13.6056	5.9651	6.1938



UNIVERSITAS ATMA JAYA YOGYAKARTA
Fakultas Teknik Program Studi Teknik Sipil
Laboratorium Struktur dan Bahan Bangunan

Jl. Babarsari No.44 Yogyakarta 55281 Indonesia Kotak Pos 1086
Telp.+62-274-487711 (hunting) Fax. +62-274-487748

Lampiran 10
Halaman 111

Silinder BN-2 (7 Hari)

$E_c = 19950.8099 \text{ MPa}$

Beban	ΔP (mm)	0.5 ΔP (mm)	Tegangan (f) (MPa)	Regangan (ϵ) (10^{-4})	Regangan Koreksi (ϵ) (10^{-4})
0	0	0	0.0000	-0.1571	0.0000
500	1	0.5	0.2794	0.0248	0.1819
1000	3	1.5	0.5588	0.0745	0.2316
1500	6	3	0.8382	0.1490	0.3061
2000	10	5	1.1177	0.2483	0.4054
2500	14	7	1.3971	0.3477	0.5048
3000	18	9	1.6765	0.4470	0.6041
3500	23	11.5	1.9559	0.5712	0.7283
4000	28	14	2.2353	0.6954	0.8525
4500	34	17	2.5147	0.8444	1.0015
5000	40	20	2.7941	0.9934	1.1505
5500	44	22	3.0735	1.0927	1.2498
6000	49	24.5	3.3530	1.2169	1.3740
6500	54	27	3.6324	1.3411	1.4982
7000	59	29.5	3.9118	1.4653	1.6224
7500	64	32	4.1912	1.5894	1.7465
8000	68	34	4.4706	1.6888	1.8459
8500	73	36.5	4.7500	1.8129	1.9700
9000	76	38	5.0294	1.8874	2.0445
9500	81	40.5	5.3089	2.0116	2.1687
10000	86	43	5.5883	2.1358	2.2929
10500	91	45.5	5.8677	2.2600	2.4171
11000	96	48	6.1471	2.3841	2.5412
11500	101	50.5	6.4265	2.5083	2.6654
12000	106	53	6.7059	2.6325	2.7896
12500	111	55.5	6.9853	2.7567	2.9138
13000	118	59	7.2648	2.9305	3.0876
13500	124	62	7.5442	3.0795	3.2366
14000	130	65	7.8236	3.2285	3.3856
14500	135	67.5	8.1030	3.3527	3.5098
15000	141	70.5	8.3824	3.5017	3.6588
15500	146	73	8.6618	3.6259	3.7830



UNIVERSITAS ATMA JAYA YOGYAKARTA
Fakultas Teknik Program Studi Teknik Sipil
Laboratorium Struktur dan Bahan Bangunan

Jl. Babarsari No.44 Yogyakarta 55281 Indonesia Kotak Pos 1086
Telp. +62-274-487711 (hunting) Fax. +62-274-487748

Lampiran 10
Halaman 112

16000	151	75.5	8.9412	3.7501	3.9072
16500	157	78.5	9.2206	3.8991	4.0562
17000	165	82.5	9.5001	4.0977	4.2548
17500	174	87	9.7795	4.3213	4.4784
18000	182	91	10.0589	4.5199	4.6770
18500	189	94.5	10.3383	4.6938	4.8509
19000	196	98	10.6177	4.8676	5.0247
19500	203	101.5	10.8971	5.0415	5.1986
20000	210	105	11.1765	5.2153	5.3724
20500	216	108	11.4560	5.3643	5.5214
21000	222	111	11.7354	5.5133	5.6704
21500	229	114.5	12.0148	5.6872	5.8443
22000	237	118.5	12.2942	5.8859	6.0430
22500	244	122	12.5736	6.0597	6.2168
23000	251	125.5	12.8530	6.2335	6.3906
23500	257	128.5	13.1324	6.3826	6.5397
24000	263	131.5	13.4118	6.5316	6.6887
24500	270	135	13.6913	6.7054	6.8625



Silinder BN-3 (7 Hari)

$E_c = 4951.1114 \text{ MPa}$

Beban	ΔP (mm)	0.5 ΔP (mm)	Tegangan (f) (MPa)	Regangan (ϵ) (10^{-4})	Regangan Koreksi (ϵ) (10^{-4})
0	0	0	0.0000	-0.5460	0.0000
500	1	0.5	0.2794	0.0249	0.5708
1000	6	3	0.5588	0.1491	0.6951
1500	13	6.5	0.8382	0.3231	0.8691
2000	20	10	1.1177	0.4971	1.0430
2500	27	13.5	1.3971	0.6710	1.2170
3000	35	17.5	1.6765	0.8699	1.4158
3500	43	21.5	1.9559	1.0687	1.6147
4000	50	25	2.2353	1.2427	1.7886
4500	59	29.5	2.5147	1.4663	2.0123
5000	67	33.5	2.7941	1.6652	2.2111
5500	76	38	3.0735	1.8889	2.4348
6000	85	42.5	3.3530	2.1125	2.6585
6500	97	48.5	3.6324	2.4108	2.9567
7000	110	55	3.9118	2.7339	3.2798
7500	120	60	4.1912	2.9824	3.5284
8000	125	62.5	4.4706	3.1067	3.6526
8500	153	76.5	4.7500	3.8026	4.3485
9000	175	87.5	5.0294	4.3493	4.8953
9500	200	100	5.3089	4.9707	5.5166
10000	243	121.5	5.5883	6.0394	6.5853
10500	300	150	5.8677	7.4560	8.0020
11000	375	187.5	6.1471	9.3200	9.8660
11500	475	237.5	6.4265	11.8053	12.3513
12000	523	261.5	6.7059	12.9983	13.5443



UNIVERSITAS ATMA JAYA YOGYAKARTA
Fakultas Teknik Program Studi Teknik Sipil
Laboratorium Struktur dan Bahan Bangunan

Jl. Babarsari No.44 Yogyakarta 55281 Indonesia Kotak Pos 1086
Telp.+62-274-487711 (hunting) Fax. +62-274-487748

Lampiran 10
Halaman 114

Silinder BN-1 (14 Hari)

$E_c = 25304,4712 \text{ MPa}$

Beban	ΔP (mm)	0.5 ΔP (mm)	Tegangan (f) (MPa)	Regangan (ϵ) (10^{-4})	Regangan Koreksi (ϵ) (10^{-4})
0	0	0	0.0000	-0.0624	0.0000
500	1	0.5	0.2771	0.0248	0.0872
1000	3	1.5	0.5542	0.0744	0.1368
1500	7	3.5	0.8313	0.1737	0.2361
2000	10	5	1.1083	0.2481	0.3105
2500	14	7	1.3854	0.3473	0.4097
3000	16	8	1.6625	0.3969	0.4593
3500	20	10	1.9396	0.4962	0.5586
4000	23	11.5	2.2167	0.5706	0.6330
4500	27	13.5	2.4938	0.6698	0.7322
5000	30	15	2.7709	0.7443	0.8067
5500	33	16.5	3.0479	0.8187	0.8811
6000	36	18	3.3250	0.8931	0.9555
6500	41	20.5	3.6021	1.0172	1.0796
7000	44	22	3.8792	1.0916	1.1540
7500	48	24	4.1563	1.1908	1.2532
8000	50	25	4.4334	1.2404	1.3028
8500	55	27.5	4.7105	1.3645	1.4269
9000	60	30	4.9875	1.4885	1.5509
9500	64	32	5.2646	1.5878	1.6502
10000	67	33.5	5.5417	1.6622	1.7246
10500	70	35	5.8188	1.7366	1.7990
11000	74	37	6.0959	1.8359	1.8983
11500	78	39	6.3730	1.9351	1.9975
12000	82	41	6.6501	2.0343	2.0967
12500	85	42.5	6.9271	2.1088	2.1712
13000	90	45	7.2042	2.2328	2.2952
13500	94	47	7.4813	2.3320	2.3944
14000	97	48.5	7.7584	2.4065	2.4689
14500	100	50	8.0355	2.4809	2.5433
15000	105	52.5	8.3126	2.6049	2.6673
15500	109	54.5	8.5897	2.7042	2.7666
16000	113	56.5	8.8667	2.8034	2.8658



UNIVERSITAS ATMA JAYA YOGYAKARTA
Fakultas Teknik Program Studi Teknik Sipil
Laboratorium Struktur dan Bahan Bangunan

Jl. Babarsari No.44 Yogyakarta 55281 Indonesia Kotak Pos 1086
Telp.+62-274-487711 (hunting) Fax. +62-274-487748

Lampiran 10
Halaman 115

16500	118	59	9.1438	2.9275	2.9899
17000	124	62	9.4209	3.0763	3.1387
17500	130	65	9.6980	3.2252	3.2876
18000	135	67.5	9.9751	3.3492	3.4116
18500	139	69.5	10.2522	3.4484	3.5108
19000	144	72	10.5293	3.5725	3.6349
19500	150	75	10.8063	3.7213	3.7837
20000	155	77.5	11.0834	3.8454	3.9078
20500	159	79.5	11.3605	3.9446	4.0070
21000	164	82	11.6376	4.0687	4.1311
21500	170	85	11.9147	4.2175	4.2799
22000	176	88	12.1918	4.3664	4.4288
22500	183	91.5	12.4689	4.5400	4.6024
23000	189	94.5	12.7459	4.6889	4.7513
23500	196	98	13.0230	4.8626	4.9250
24000	202	101	13.3001	5.0114	5.0738
24500	209	104.5	13.5772	5.1851	5.2475
25000	214	107	13.8543	5.3091	5.3715
25500	221	110.5	14.1314	5.4828	5.5452
26000	227	113.5	14.4085	5.6316	5.6940



Silinder BN-2 (14 Hari)

$E_c = 27910,6942 \text{ MPa}$

Beban	ΔP (mm)	0.5 ΔP (mm)	Tegangan (f) (MPa)	Regangan (ϵ) (10^{-4})	Regangan Koreksi (ϵ) (10^{-4})
0	0	0	0.0000	-0.0989	0.0000
500	1	0.5	0.2822	0.0248	0.1237
1000	3	1.5	0.5644	0.0744	0.1733
1500	5	2.5	0.8466	0.1240	0.2229
2000	8	4	1.1288	0.1984	0.2973
2500	10	5	1.4110	0.2480	0.3469
3000	13	6.5	1.6932	0.3224	0.4213
3500	15	7.5	1.9754	0.3720	0.4709
4000	18	9	2.2576	0.4464	0.5453
4500	21	10.5	2.5398	0.5208	0.6197
5000	24	12	2.8220	0.5952	0.6941
5500	26	13	3.1042	0.6448	0.7437
6000	29	14.5	3.3864	0.7192	0.8181
6500	33	16.5	3.6686	0.8185	0.9174
7000	35	17.5	3.9508	0.8681	0.9670
7500	39	19.5	4.2330	0.9673	1.0662
8000	42	21	4.5152	1.0417	1.1406
8500	45	22.5	4.7974	1.1161	1.2150
9000	49	24.5	5.0796	1.2153	1.3142
9500	52	26	5.3618	1.2897	1.3886
10000	55	27.5	5.6440	1.3641	1.4630
10500	57	28.5	5.9262	1.4137	1.5126
11000	60	30	6.2084	1.4881	1.5870
11500	64	32	6.4906	1.5873	1.6862
12000	68	34	6.7728	1.6865	1.7854
12500	71	35.5	7.0550	1.7609	1.8598
13000	75	37.5	7.3372	1.8601	1.9590
13500	78	39	7.6194	1.9345	2.0334
14000	82	41	7.9016	2.0337	2.1326
14500	87	43.5	8.1838	2.1577	2.2566
15000	92	46	8.4660	2.2817	2.3806
15500	96	48	8.7482	2.3810	2.4799
16000	99	49.5	9.0304	2.4554	2.5543



UNIVERSITAS ATMA JAYA YOGYAKARTA
Fakultas Teknik Program Studi Teknik Sipil
Laboratorium Struktur dan Bahan Bangunan

Jl. Babarsari No.44 Yogyakarta 55281 Indonesia Kotak Pos 1086
Telp. +62-274-487711 (hunting) Fax. +62-274-487748

Lampiran 10
Halaman 117

16500	103	51.5	9.3126	2.5546	2.6535
17000	108	54	9.5948	2.6786	2.7775
17500	112	56	9.8770	2.7778	2.8767
18000	117	58.5	10.1592	2.9018	3.0007
18500	121	60.5	10.4414	3.0010	3.0999
19000	126	63	10.7236	3.1250	3.2239
19500	132	66	11.0058	3.2738	3.3727
20000	138	69	11.2880	3.4226	3.5215
20500	144	72	11.5702	3.5714	3.6703
21000	151	75.5	11.8524	3.7450	3.8439
21500	157	78.5	12.1346	3.8938	3.9927
22000	160	80	12.4168	3.9683	4.0672
22500	165	82.5	12.6990	4.0923	4.1912
23000	169	84.5	12.9812	4.1915	4.2904
23500	173	86.5	13.2634	4.2907	4.3896
24000	179	89.5	13.5456	4.4395	4.5384
24500	185	92.5	13.8278	4.5883	4.6872
25000	193	96.5	14.1100	4.7867	4.8856
25500	200	100	14.3922	4.9603	5.0592
26000	208	104	14.6744	5.1587	5.2576



Silinder BN-3 (14 Hari)

$E_c = 28239,6189 \text{ MPa}$

Beban	ΔP (mm)	0.5 ΔP (mm)	Tegangan (f) (MPa)	Regangan (ϵ) (10^{-4})	Regangan Koreksi (ϵ) (10^{-4})
0	0	0	0.0000	-0.0505	0.0000
500	1	0.5	0.2807	0.0248	0.0753
1000	4	2	0.5614	0.0994	0.1499
1500	7	3.5	0.8421	0.1739	0.2244
2000	10	5	1.1229	0.2485	0.2990
2500	12	6	1.4036	0.2982	0.3487
3000	15	7.5	1.6843	0.3727	0.4232
3500	18	9	1.9650	0.4472	0.4977
4000	20	10	2.2457	0.4969	0.5474
4500	24	12	2.5264	0.5963	0.6468
5000	26	13	2.8071	0.6460	0.6965
5500	29	14.5	3.0879	0.7206	0.7711
6000	32	16	3.3686	0.7951	0.8456
6500	35	17.5	3.6493	0.8697	0.9202
7000	38	19	3.9300	0.9442	0.9947
7500	41	20.5	4.2107	1.0187	1.0692
8000	44	22	4.4914	1.0933	1.1438
8500	48	24	4.7721	1.1927	1.2432
9000	51	25.5	5.0528	1.2672	1.3177
9500	54	27	5.3336	1.3417	1.3922
10000	57	28.5	5.6143	1.4163	1.4668
10500	60	30	5.8950	1.4908	1.5413
11000	64	32	6.1757	1.5902	1.6407
11500	67	33.5	6.4564	1.6648	1.7153
12000	70	35	6.7371	1.7393	1.7898
12500	74	37	7.0178	1.8387	1.8892
13000	77	38.5	7.2986	1.9132	1.9637
13500	81	40.5	7.5793	2.0126	2.0631
14000	84	42	7.8600	2.0872	2.1377
14500	88	44	8.1407	2.1866	2.2371
15000	92	46	8.4214	2.2859	2.3364
15500	96	48	8.7021	2.3853	2.4358
16000	101	50.5	8.9828	2.5096	2.5601



UNIVERSITAS ATMA JAYA YOGYAKARTA
Fakultas Teknik Program Studi Teknik Sipil
Laboratorium Struktur dan Bahan Bangunan

Jl. Babarsari No.44 Yogyakarta 55281 Indonesia Kotak Pos 1086
Telp.+62-274-487711 (hunting) Fax. +62-274-487748

Lampiran 10
Halaman 119

16500	106	53	9.2636	2.6338	2.6843
17000	110	55	9.5443	2.7332	2.7837
17500	115	57.5	9.8250	2.8574	2.9079
18000	119	59.5	10.1057	2.9568	3.0073
18500	125	62.5	10.3864	3.1059	3.1564
19000	130	65	10.6671	3.2301	3.2806
19500	136	68	10.9478	3.3792	3.4297
20000	140	70	11.2286	3.4786	3.5291
20500	144	72	11.5093	3.5780	3.6285
21000	149	74.5	11.7900	3.7022	3.7527
21500	154	77	12.0707	3.8265	3.8770
22000	158	79	12.3514	3.9259	3.9764
22500	164	82	12.6321	4.0749	4.1254
23000	168	84	12.9128	4.1743	4.2248
23500	174	87	13.1935	4.3234	4.3739
24000	182	91	13.4743	4.5222	4.5727
24500	188	94	13.7550	4.6713	4.7218
25000	195	97.5	14.0357	4.8452	4.8957
25500	200	100	14.3164	4.9694	5.0199
26000	206	103	14.5971	5.1185	5.1690



Silinder BN-1 (28 Hari)

$E_c = 26379.1345 \text{ MPa}$

Beban	ΔP (mm)	0.5 ΔP (mm)	Tegangan (f) (MPa)	Regangan (ϵ) (10^{-4})	Regangan Koreksi (ϵ) (10^{-4})
0	0	0	0.0000	-0.1853	0.0000
500	0	0	0.2771	0.0000	0.1853
1000	0	0	0.5541	0.0000	0.1853
1500	2	1	0.8312	0.0497	0.2350
2000	5	2.5	1.1083	0.1241	0.3094
2500	8	4	1.3854	0.1986	0.3839
3000	11	5.5	1.6624	0.2731	0.4584
3500	15	7.5	1.9395	0.3724	0.5577
4000	19	9.5	2.2166	0.4717	0.6570
4500	23	11.5	2.4937	0.5710	0.7563
5000	28	14	2.7707	0.6951	0.8804
5500	32	16	3.0478	0.7944	0.9797
6000	35	17.5	3.3249	0.8689	1.0542
6500	40	20	3.6020	0.9930	1.1783
7000	43	21.5	3.8790	1.0675	1.2528
7500	47	23.5	4.1561	1.1668	1.3521
8000	52	26	4.4332	1.2910	1.4763
8500	55	27.5	4.7102	1.3654	1.5507
9000	60	30	4.9873	1.4896	1.6749
9500	64	32	5.2644	1.5889	1.7742
10000	66	33	5.5415	1.6385	1.8238
10500	69	34.5	5.8185	1.7130	1.8983
11000	72	36	6.0956	1.7875	1.9728
11500	77	38.5	6.3727	1.9116	2.0969
12000	81	40.5	6.6498	2.0109	2.1962
12500	85	42.5	6.9268	2.1102	2.2955
13000	89	44.5	7.2039	2.2095	2.3948
13500	93	46.5	7.4810	2.3088	2.4941
14000	97	48.5	7.7581	2.4081	2.5934
14500	102	51	8.0351	2.5323	2.7176
15000	105	52.5	8.3122	2.6068	2.7921
15500	110	55	8.5893	2.7309	2.9162
16000	113	56.5	8.8663	2.8054	2.9907



UNIVERSITAS ATMA JAYA YOGYAKARTA
Fakultas Teknik Program Studi Teknik Sipil
Laboratorium Struktur dan Bahan Bangunan

Jl. Babarsari No.44 Yogyakarta 55281 Indonesia Kotak Pos 1086
Telp. +62-274-487711 (hunting) Fax. +62-274-487748

Lampiran 10
Halaman 121

16500	120	60	9.1434	2.9791	3.1644
17000	123	61.5	9.4205	3.0536	3.2389
17500	128	64	9.6976	3.1778	3.3631
18000	131	65.5	9.9746	3.2522	3.4375
18500	136	68	10.2517	3.3764	3.5617
19000	141	70.5	10.5288	3.5005	3.6858
19500	145	72.5	10.8059	3.5998	3.7851
20000	148	74	11.0829	3.6743	3.8596
20500	153	76.5	11.3600	3.7984	3.9837
21000	157	78.5	11.6371	3.8977	4.0830
21500	161	80.5	11.9142	3.9970	4.1823
22000	166	83	12.1912	4.1212	4.3065
22500	171	85.5	12.4683	4.2453	4.4306
23000	176	88	12.7454	4.3694	4.5547
23500	182	91	13.0225	4.5184	4.7037
24000	187	93.5	13.2995	4.6425	4.8278
24500	193	96.5	13.5766	4.7915	4.9768
25000	197	98.5	13.8537	4.8908	5.0761
25500	203	101.5	14.1307	5.0397	5.2250
26000	210	105	14.4078	5.2135	5.3988
26500	215	107.5	14.6849	5.3376	5.5229
27000	221	110.5	14.9620	5.4866	5.6719



Silinder BN-2 (28 Hari)

$E_c = 30649.9206 \text{ MPa}$

Beban	ΔP (mm)	0.5 ΔP (mm)	Tegangan (f) (MPa)	Regangan (ϵ) (10^{-4})	Regangan Koreksi (ϵ) (10^{-4})
0	0	0	0.0000	0.3376	0.0000
500	0	0	0.2614	0.0000	-0.3376
1000	0	0	0.5228	0.0000	-0.3376
1500	1	0.5	0.7842	0.0247	-0.3129
2000	3	1.5	1.0456	0.0741	-0.2635
2500	4	2	1.3070	0.0989	-0.2387
3000	6	3	1.5684	0.1483	-0.1893
3500	9	4.5	1.8298	0.2224	-0.1152
4000	12	6	2.0913	0.2966	-0.0410
4500	15	7.5	2.3527	0.3707	0.0331
5000	18	9	2.6141	0.4449	0.1073
5500	22	11	2.8755	0.5437	0.2061
6000	26	13	3.1369	0.6426	0.3050
6500	30	15	3.3983	0.7415	0.4039
7000	34	17	3.6597	0.8403	0.5027
7500	35	17.5	3.9211	0.8651	0.5275
8000	40	20	4.1825	0.9886	0.6510
8500	45	22.5	4.4439	1.1122	0.7746
9000	50	25	4.7053	1.2358	0.8982
9500	53	26.5	4.9667	1.3099	0.9723
10000	57	28.5	5.2281	1.4088	1.0712
10500	61	30.5	5.4895	1.5077	1.1701
11000	65	32.5	5.7510	1.6065	1.2689
11500	70	35	6.0124	1.7301	1.3925
12000	74	37	6.2738	1.8290	1.4914
12500	78	39	6.5352	1.9278	1.5902
13000	82	41	6.7966	2.0267	1.6891
13500	86	43	7.0580	2.1256	1.7880
14000	91	45.5	7.3194	2.2491	1.9115
14500	96	48	7.5808	2.3727	2.0351
15000	100	50	7.8422	2.4716	2.1340
15500	105	52.5	8.1036	2.5952	2.2576
16000	109	54.5	8.3650	2.6940	2.3564



UNIVERSITAS ATMA JAYA YOGYAKARTA
Fakultas Teknik Program Studi Teknik Sipil
Laboratorium Struktur dan Bahan Bangunan

Jl. Babarsari No.44 Yogyakarta 55281 Indonesia Kotak Pos 1086
Telp. +62-274-487711 (hunting) Fax. +62-274-487748

Lampiran 10
Halaman 123

16500	113	56.5	8.6264	2.7929	2.4553
17000	116	58	8.8878	2.8670	2.5294
17500	120	60	9.1492	2.9659	2.6283
18000	124	62	9.4107	3.0648	2.7272
18500	129	64.5	9.6721	3.1883	2.8507
19000	133	66.5	9.9335	3.2872	2.9496
19500	136	68	10.1949	3.3613	3.0237
20000	140	70	10.4563	3.4602	3.1226
20500	144	72	10.7177	3.5591	3.2215
21000	149	74.5	10.9791	3.6826	3.3450
21500	154	77	11.2405	3.8062	3.4686
22000	158	79	11.5019	3.9051	3.5675
22500	162	81	11.7633	4.0040	3.6664
23000	166	83	12.0247	4.1028	3.7652
23500	170	85	12.2861	4.2017	3.8641
24000	175	87.5	12.5475	4.3253	3.9877
24500	180	90	12.8089	4.4488	4.1112
25000	185	92.5	13.0704	4.5724	4.2348
25500	189	94.5	13.3318	4.6713	4.3337
26000	192	96	13.5932	4.7454	4.4078
26500	198	99	13.8546	4.8937	4.5561
27000	200	100	14.1160	4.9432	4.6056



Silinder BN-3 (28 Hari)

$E_c = 28557.0902 \text{ MPa}$

Beban	ΔP (mm)	0.5 ΔP (mm)	Tegangan (f) (MPa)	Regangan (ϵ) (10^{-4})	Regangan Koreksi (ϵ) (10^{-4})
0	0	0	0.0000	-0.3029	0.0000
500	0	0	0.2836	0.0000	0.3029
1000	2	1	0.5672	0.0496	0.3525
1500	3	1.5	0.8508	0.0744	0.3773
2000	4	2	1.1343	0.0992	0.4021
2500	5	2.5	1.4179	0.1240	0.4269
3000	7	3.5	1.7015	0.1736	0.4765
3500	9	4.5	1.9851	0.2232	0.5261
4000	11	5.5	2.2687	0.2728	0.5757
4500	14	7	2.5523	0.3472	0.6501
5000	17	8.5	2.8358	0.4216	0.7245
5500	20	10	3.1194	0.4960	0.7989
6000	24	12	3.4030	0.5952	0.8981
6500	27	13.5	3.6866	0.6696	0.9725
7000	30	15	3.9702	0.7440	1.0469
7500	33	16.5	4.2538	0.8185	1.1214
8000	34	17	4.5373	0.8433	1.1462
8500	38	19	4.8209	0.9425	1.2454
9000	41	20.5	5.1045	1.0169	1.3198
9500	44	22	5.3881	1.0913	1.3942
10000	47	23.5	5.6717	1.1657	1.4686
10500	51	25.5	5.9553	1.2649	1.5678
11000	55	27.5	6.2388	1.3641	1.6670
11500	60	30	6.5224	1.4881	1.7910
12000	64	32	6.8060	1.5873	1.8902
12500	68	34	7.0896	1.6865	1.9894
13000	73	36.5	7.3732	1.8105	2.1134
13500	78	39	7.6568	1.9345	2.2374
14000	83	41.5	7.9403	2.0585	2.3614
14500	88	44	8.2239	2.1825	2.4854
15000	93	46.5	8.5075	2.3065	2.6094
15500	98	49	8.7911	2.4306	2.7335
16000	102	51	9.0747	2.5298	2.8327



UNIVERSITAS ATMA JAYA YOGYAKARTA
Fakultas Teknik Program Studi Teknik Sipil
Laboratorium Struktur dan Bahan Bangunan

Jl. Babarsari No.44 Yogyakarta 55281 Indonesia Kotak Pos 1086
Telp. +62-274-487711 (hunting) Fax. +62-274-487748

Lampiran 10
Halaman 125

16500	107	53.5	9.3583	2.6538	2.9567
17000	112	56	9.6418	2.7778	3.0807
17500	117	58.5	9.9254	2.9018	3.2047
18000	121	60.5	10.2090	3.0010	3.3039
18500	125	62.5	10.4926	3.1002	3.4031
19000	130	65	10.7762	3.2242	3.5271
19500	134	67	11.0598	3.3234	3.6263
20000	139	69.5	11.3433	3.4474	3.7503
20500	143	71.5	11.6269	3.5466	3.8495
21000	148	74	11.9105	3.6706	3.9735
21500	153	76.5	12.1941	3.7946	4.0975
22000	158	79	12.4777	3.9187	4.2216
22500	163	81.5	12.7613	4.0427	4.3456
23000	167	83.5	13.0449	4.1419	4.4448
23500	172	86	13.3284	4.2659	4.5688
24000	177	88.5	13.6120	4.3899	4.6928
24500	181	90.5	13.8956	4.4891	4.7920
25000	186	93	14.1792	4.6131	4.9160
25500	190	95	14.4628	4.7123	5.0152
26000	194	97	14.7464	4.8115	5.1144
26500	199	99.5	15.0299	4.9355	5.2384
27000	204	102	15.3135	5.0595	5.3624



Silinder BS-1 (7 Hari)

$E_c = 14905.1781 \text{ MPa}$

Beban	ΔP (mm)	0,5 ΔP (mm)	Tegangan (f) (MPa)	Regangan (ϵ) (10^{-4})	Regangan Koreksi (ϵ) (10^{-4})
0	0	0	0.0000	-0.2883	0.0000
500	0	0	0.2761	0.0000	0.2883
1000	2	1	0.5523	0.0474	0.3357
1500	4	2	0.8284	0.0947	0.3830
2000	6	3	1.1045	0.1421	0.4304
2500	9	4.5	1.3806	0.2132	0.5015
3000	12	6	1.6568	0.2842	0.5725
3500	16	8	1.9329	0.3790	0.6673
4000	21	10.5	2.2090	0.4974	0.7857
4500	26	13	2.4852	0.6159	0.9042
5000	31	15.5	2.7613	0.7343	1.0226
5500	36	18	3.0374	0.8527	1.1410
6000	41	20.5	3.3135	0.9711	1.2594
6500	45	22.5	3.5897	1.0659	1.3542
7000	49	24.5	3.8658	1.1606	1.4489
7500	54	27	4.1419	1.2791	1.5674
8000	60	30	4.4181	1.4212	1.7095
8500	75	37.5	4.6942	1.7765	2.0648
9000	85	42.5	4.9703	2.0134	2.3017
9500	96	48	5.2464	2.2739	2.5622
10000	105	52.5	5.5226	2.4871	2.7754
10500	120	60	5.7987	2.8424	3.1307
11000	136	68	6.0748	3.2214	3.5097
11500	145	72.5	6.3510	3.4346	3.7229
12000	159	79.5	6.6271	3.7662	4.0545
12500	174	87	6.9032	4.1215	4.4098
13000	188	94	7.1793	4.4531	4.7414
13500	199	99.5	7.4555	4.7136	5.0019



UNIVERSITAS ATMA JAYA YOGYAKARTA
Fakultas Teknik Program Studi Teknik Sipil
Laboratorium Struktur dan Bahan Bangunan

Jl. Babarsari No.44 Yogyakarta 55281 Indonesia Kotak Pos 1086
Telp. +62-274-487711 (hunting) Fax. +62-274-487748

Lampiran 10
Halaman 127

Silinder BS-2 (7 Hari)

$E_c = 14337.1032 \text{ MPa}$

Beban	ΔP (mm)	0,5 ΔP (mm)	Tegangan (f) (MPa)	Regangan (ϵ) (10^{-4})	Regangan Koreksi (ϵ) (10^{-4})
0	0	0	0.0000	-0.2817	0.0000
500	1	0.5	0.2782	0.0248	0.3065
1000	4	2	0.5564	0.0991	0.3808
1500	6	3	0.8346	0.1487	0.4304
2000	9	4.5	1.1128	0.2231	0.5048
2500	13	6.5	1.3910	0.3222	0.6039
3000	17	8.5	1.6692	0.4214	0.7031
3500	20	10	1.9474	0.4957	0.7774
4000	25	12.5	2.2256	0.6197	0.9014
4500	27	13.5	2.5038	0.6692	0.9509
5000	32	16	2.7820	0.7932	1.0749
5500	36	18	3.0602	0.8923	1.1740
6000	41	20.5	3.3384	1.0163	1.2980
6500	45	22.5	3.6166	1.1154	1.3971
7000	52	26	3.8948	1.2889	1.5706
7500	70	35	4.1729	1.7351	2.0168
8000	75	37.5	4.4511	1.8590	2.1407
8500	87	43.5	4.7293	2.1565	2.4382
9000	97	48.5	5.0075	2.4043	2.6860
9500	107	53.5	5.2857	2.6522	2.9339
10000	116	58	5.5639	2.8753	3.1570
10500	123	61.5	5.8421	3.0488	3.3305
11000	130	65	6.1203	3.2223	3.5040
11500	141	70.5	6.3985	3.4949	3.7766
12000	153	76.5	6.6767	3.7924	4.0741
12500	165	82.5	6.9549	4.0898	4.3715
13000	181	90.5	7.2331	4.4864	4.7681
13500	200	100	7.5113	4.9574	5.2391



Silinder BS-3 (7 Hari)

$E_c = 14537.5422 \text{ MPa}$

Beban	ΔP (mm)	0,5 ΔP (mm)	Tegangan (f) (MPa)	Regangan (ϵ) (10^{-4})	Regangan Koreksi (ϵ) (10^{-4})
0	0	0	0.0000	-0.2613	0.0000
500	2	1	0.2782	0.0486	0.3099
1000	4	2	0.5564	0.0971	0.3584
1500	9	4.5	0.8346	0.2186	0.4799
2000	13	6.5	1.1128	0.3157	0.5770
2500	16	8	1.3910	0.3886	0.6499
3000	20	10	1.6692	0.4857	0.7470
3500	24	12	1.9474	0.5828	0.8441
4000	29	14.5	2.2256	0.7043	0.9656
4500	33	16.5	2.5038	0.8014	1.0627
5000	38	19	2.7820	0.9228	1.1841
5500	42	21	3.0602	1.0200	1.2813
6000	52	26	3.3384	1.2628	1.5241
6500	62	31	3.6166	1.5057	1.7670
7000	71	35.5	3.8948	1.7242	1.9855
7500	80	40	4.1729	1.9428	2.2041
8000	90	45	4.4511	2.1856	2.4469
8500	99	49.5	4.7293	2.4042	2.6655
9000	108	54	5.0075	2.6228	2.8841
9500	118	59	5.2857	2.8656	3.1269
10000	127	63.5	5.5639	3.0842	3.3455
10500	136	68	5.8421	3.3027	3.5640
11000	145	72.5	6.1203	3.5213	3.7826
11500	152	76	6.3985	3.6913	3.9526
12000	159	79.5	6.6767	3.8613	4.1226
12500	175	87.5	6.9549	4.2498	4.5111
13000	189	94.5	7.2331	4.5898	4.8511
13500	202	101	7.5113	4.9055	5.1668



UNIVERSITAS ATMA JAYA YOGYAKARTA
Fakultas Teknik Program Studi Teknik Sipil
Laboratorium Struktur dan Bahan Bangunan

Jl. Babarsari No.44 Yogyakarta 55281 Indonesia Kotak Pos 1086
Telp.+62-274-487711 (hunting) Fax. +62-274-487748

Lampiran 10
Halaman 129

Silinder BS-1 (14 Hari)

$E_c = 14585,0851 \text{ MPa}$

Beban	ΔP (mm)	0,5 ΔP (mm)	Tegangan (f) (MPa)	Regangan (ϵ) (10^{-4})	Regangan Koreksi (ϵ) (10^{-4})
0	0	0	0,0000	-1,5102	0,0000
500	0	0	0,2807	0,0000	1,5102
1000	1	0,5	0,5614	0,0247	1,5349
1500	9	4,5	0,8421	0,2225	1,7327
2000	15	7,5	1,1228	0,3709	1,8811
2500	24	12	1,4034	0,5934	2,1036
3000	40	20	1,6841	0,9890	2,4992
3500	49	24,5	1,9648	1,2115	2,7217
4000	63	31,5	2,2455	1,5576	3,0678
4500	75	37,5	2,5262	1,8543	3,3645
5000	87	43,5	2,8069	2,1510	3,6612
5500	100	50	3,0876	2,4724	3,9826
6000	109	54,5	3,3683	2,6950	4,2052
6500	115	57,5	3,6490	2,8433	4,3535
7000	123	61,5	3,9296	3,0411	4,5513
7500	125	62,5	4,2103	3,0905	4,6007
8000	130	65	4,4910	3,2142	4,7244
8500	133	66,5	4,7717	3,2883	4,7985
9000	137	68,5	5,0524	3,3872	4,8974
9500	141	70,5	5,3331	3,4861	4,9963
10000	145	72,5	5,6138	3,5850	5,0952
10500	146	73	5,8945	3,6098	5,1200
11000	148	74	6,1752	3,6592	5,1694
11500	149	74,5	6,4558	3,6839	5,1941
12000	152	76	6,7365	3,7581	5,2683
12500	155	77,5	7,0172	3,8323	5,3425
13000	159	79,5	7,2979	3,9312	5,4414
13500	163	81,5	7,5786	4,0301	5,5403
14000	168	84	7,8593	4,1537	5,6639
14500	173	86,5	8,1400	4,2773	5,7875
15000	177	88,5	8,4207	4,3762	5,8864
15500	182	91	8,7014	4,4998	6,0100
16000	188	94	8,9820	4,6482	6,1584



Silinder BS-2 (14 Hari)

$E_c = 22120,8962 \text{ MPa}$

Beban	ΔP (mm)	0,5 ΔP (mm)	Tegangan (f) (MPa)	Regangan (ϵ) (10^{-4})	Regangan Koreksi (ϵ) (10^{-4})
0	0	0	0.0000	-0.2700	0.0000
500	0	0	0.2761	0.0000	0.2700
1000	0	0	0.5522	0.0000	0.2700
1500	2	1	0.8283	0.0497	0.3197
2000	6	3	1.1044	0.1490	0.4190
2500	11	5.5	1.3805	0.2731	0.5431
3000	15	7.5	1.6566	0.3724	0.6424
3500	20	10	1.9326	0.4965	0.7665
4000	25	12.5	2.2087	0.6207	0.8907
4500	29	14.5	2.4848	0.7200	0.9900
5000	34	17	2.7609	0.8441	1.1141
5500	40	20	3.0370	0.9930	1.2630
6000	44	22	3.3131	1.0924	1.3624
6500	50	25	3.5892	1.2413	1.5113
7000	54	27	3.8653	1.3406	1.6106
7500	60	30	4.1414	1.4896	1.7596
8000	65	32.5	4.4175	1.6137	1.8837
8500	70	35	4.6936	1.7378	2.0078
9000	75	37.5	4.9697	1.8620	2.1320
9500	81	40.5	5.2457	2.0109	2.2809
10000	87	43.5	5.5218	2.1599	2.4299
10500	91	45.5	5.7979	2.2592	2.5292
11000	98	49	6.0740	2.4330	2.7030
11500	104	52	6.3501	2.5819	2.8519
12000	109	54.5	6.6262	2.7061	2.9761
12500	114	57	6.9023	2.8302	3.1002
13000	120	60	7.1784	2.9791	3.2491
13500	125	62.5	7.4545	3.1033	3.3733
14000	130	65	7.7306	3.2274	3.4974
14500	135	67.5	8.0067	3.3515	3.6215
15000	139	69.5	8.2828	3.4508	3.7208
15500	144	72	8.5588	3.5750	3.8450
16000	150	75	8.8349	3.7239	3.9939



Silinder BS-3 (14 Hari)

$E_c = 19008,8552 \text{ MPa}$

Beban	ΔP (mm)	0,5 ΔP (mm)	Tegangan (f) (MPa)	Regangan (ϵ) (10^{-4})	Regangan Koreksi (ϵ) (10^{-4})
0	0	0	0,0000	-0,0086	0,0000
500	4	2	0,2791	0,0987	0,1073
1000	7	3,5	0,5581	0,1728	0,1814
1500	9	4,5	0,8372	0,2221	0,2307
2000	13	6,5	1,1162	0,3208	0,3294
2500	17	8,5	1,3953	0,4195	0,4281
3000	22	11	1,6743	0,5429	0,5515
3500	28	14	1,9534	0,6910	0,6996
4000	33	16,5	2,2324	0,8144	0,8230
4500	37	18,5	2,5115	0,9131	0,9217
5000	42	21	2,7905	1,0365	1,0451
5500	47	23,5	3,0696	1,1599	1,1685
6000	52	26	3,3486	1,2833	1,2919
6500	58	29	3,6277	1,4314	1,4400
7000	62	31	3,9067	1,5301	1,5387
7500	68	34	4,1858	1,6782	1,6868
8000	74	37	4,4648	1,8263	1,8349
8500	78	39	4,7439	1,9250	1,9336
9000	85	42,5	5,0229	2,0977	2,1063
9500	92	46	5,3020	2,2705	2,2791
10000	99	49,5	5,5811	2,4432	2,4518
10500	105	52,5	5,8601	2,5913	2,5999
11000	114	57	6,1392	2,8134	2,8220
11500	117	58,5	6,4182	2,8875	2,8961
12000	124	62	6,6973	3,0602	3,0688
12500	132	66	6,9763	3,2577	3,2663
13000	140	70	7,2554	3,4551	3,4637
13500	148	74	7,5344	3,6525	3,6611
14000	155	77,5	7,8135	3,8253	3,8339
14500	163	81,5	8,0925	4,0227	4,0313
15000	172	86	8,3716	4,2448	4,2534
15500	181	90,5	8,6506	4,4669	4,4755
16000	190	95	8,9297	4,6890	4,6976



Silinder BS-1 (28 Hari)

$E_c = 24125.0764 \text{ MPa}$

Beban	ΔP (mm)	0,5 ΔP (mm)	Tegangan (f) (MPa)	Regangan (ϵ) (10^{-4})	Regangan Koreksi (ϵ) (10^{-4})
0	0	0	0.0000	-0.1622	0.0000
500	1	0.5	0.2789	0.0247	0.1869
1000	2	1	0.5577	0.0494	0.2116
1500	3	1.5	0.8366	0.0741	0.2363
2000	7	3.5	1.1154	0.1728	0.3350
2500	9	4.5	1.3943	0.2222	0.3844
3000	11	5.5	1.6731	0.2716	0.4338
3500	13	6.5	1.9520	0.3210	0.4832
4000	16	8	2.2308	0.3951	0.5573
4500	19	9.5	2.5097	0.4691	0.6313
5000	24	12	2.7885	0.5926	0.7548
5500	28	14	3.0674	0.6914	0.8536
6000	32	16	3.3462	0.7901	0.9523
6500	36	18	3.6251	0.8889	1.0511
7000	40	20	3.9040	0.9877	1.1499
7500	44	22	4.1828	1.0864	1.2486
8000	49	24.5	4.4617	1.2099	1.3721
8500	53	26.5	4.7405	1.3086	1.4708
9000	57	28.5	5.0194	1.4074	1.5696
9500	61	30.5	5.2982	1.5062	1.6684
10000	65	32.5	5.5771	1.6049	1.7671
10500	68	34	5.8559	1.6790	1.8412
11000	72	36	6.1348	1.7778	1.9400
11500	76	38	6.4136	1.8765	2.0387
12000	80	40	6.6925	1.9753	2.1375
12500	85	42.5	6.9713	2.0988	2.2610
13000	90	45	7.2502	2.2222	2.3844
13500	96	48	7.5290	2.3704	2.5326
14000	102	51	7.8079	2.5185	2.6807
14500	107	53.5	8.0868	2.6420	2.8042
15000	113	56.5	8.3656	2.7901	2.9523
15500	119	59.5	8.6445	2.9383	3.1005
16000	127	63.5	8.9233	3.1358	3.2980



UNIVERSITAS ATMA JAYA YOGYAKARTA
Fakultas Teknik Program Studi Teknik Sipil
Laboratorium Struktur dan Bahan Bangunan

Jl. Babarsari No.44 Yogyakarta 55281 Indonesia Kotak Pos 1086
Telp. +62-274-487711 (hunting) Fax. +62-274-487748

Lampiran 10
Halaman 133

16500	133	66.5	9.2022	3.2840	3.4462
17000	139	69.5	9.4810	3.4321	3.5943
17500	146	73	9.7599	3.6049	3.7671
18000	153	76.5	10.0387	3.7778	3.9400
18500	160	80	10.3176	3.9506	4.1128
19000	168	84	10.5964	4.1481	4.3103
19500	176	88	10.8753	4.3457	4.5079



Silinder BS-2 (28 Hari)

$E_c = 26934.6585 \text{ MPa}$

Beban	ΔP (mm)	0,5 ΔP (mm)	Tegangan (f) (MPa)	Regangan (ϵ) (10^{-4})	Regangan Koreksi (ϵ) (10^{-4})
0	0	0	0.0000	-0.1204	0.0000
500	1	0.5	0.2747	0.0246	0.1450
1000	3	1.5	0.5495	0.0737	0.1941
1500	5	2.5	0.8242	0.1229	0.2433
2000	6	3	1.0989	0.1474	0.2678
2500	9	4.5	1.3736	0.2211	0.3415
3000	11	5.5	1.6484	0.2703	0.3907
3500	13	6.5	1.9231	0.3194	0.4398
4000	17	8.5	2.1978	0.4177	0.5381
4500	21	10.5	2.4725	0.5160	0.6364
5000	24	12	2.7473	0.5897	0.7101
5500	27	13.5	3.0220	0.6634	0.7838
6000	30	15	3.2967	0.7371	0.8575
6500	33	16.5	3.5714	0.8108	0.9312
7000	38	19	3.8462	0.9337	1.0541
7500	43	21.5	4.1209	1.0565	1.1769
8000	48	24	4.3956	1.1794	1.2998
8500	52	26	4.6703	1.2776	1.3980
9000	56	28	4.9451	1.3759	1.4963
9500	60	30	5.2198	1.4742	1.5946
10000	64	32	5.4945	1.5725	1.6929
10500	67	33.5	5.7692	1.6462	1.7666
11000	70	35	6.0440	1.7199	1.8403
11500	73	36.5	6.3187	1.7936	1.9140
12000	74	37	6.5934	1.8182	1.9386
12500	77	38.5	6.8682	1.8919	2.0123
13000	81	40.5	7.1429	1.9902	2.1106
13500	86	43	7.4176	2.1130	2.2334
14000	91	45.5	7.6923	2.2359	2.3563
14500	96	48	7.9671	2.3587	2.4791
15000	101	50.5	8.2418	2.4816	2.6020
15500	107	53.5	8.5165	2.6290	2.7494
16000	113	56.5	8.7912	2.7764	2.8968



UNIVERSITAS ATMA JAYA YOGYAKARTA
Fakultas Teknik Program Studi Teknik Sipil
Laboratorium Struktur dan Bahan Bangunan

Jl. Babarsari No.44 Yogyakarta 55281 Indonesia Kotak Pos 1086
Telp.+62-274-487711 (hunting) Fax. +62-274-487748

Lampiran 10
Halaman 135

16500	120	60	9.0660	2.9484	3.0688
17000	126	63	9.3407	3.0958	3.2162
17500	132	66	9.6154	3.2432	3.3636
18000	139	69.5	9.8901	3.4152	3.5356
18500	145	72.5	10.1649	3.5627	3.6831
19000	150	75	10.4396	3.6855	3.8059
19500	157	78.5	10.7143	3.8575	3.9779





UNIVERSITAS ATMA JAYA YOGYAKARTA
Fakultas Teknik Program Studi Teknik Sipil
Laboratorium Struktur dan Bahan Bangunan

Jl. Babarsari No.44 Yogyakarta 55281 Indonesia Kotak Pos 1086
Telp.+62-274-487711 (hunting) Fax. +62-274-487748

Lampiran 10
Halaman 136

Silinder BS-3 (28 Hari)

$E_c = 25981.6836 \text{ MPa}$

BEBAN	ΔP	$0.5 \Delta P$	TEGANGAN	REGANGAN (10^{-4})	REG.KOREKSI
0	0	0	0.0000	-0.1527	0.0000
500	2	1	0.2743	0.0499	0.2026
1000	3	1.5	0.5487	0.0748	0.2275
1500	4	2	0.8230	0.0998	0.2525
2000	6	3	1.0973	0.1496	0.3023
2500	8	4	1.3716	0.1995	0.3522
3000	10	5	1.6460	0.2494	0.4021
3500	13	6.5	1.9203	0.3242	0.4769
4000	16	8	2.1946	0.3990	0.5517
4500	19	9.5	2.4689	0.4738	0.6265
5000	21	10.5	2.7433	0.5237	0.6764
5500	24	12	3.0176	0.5985	0.7512
6000	27	13.5	3.2919	0.6733	0.8260
6500	30	15	3.5662	0.7481	0.9008
7000	34	17	3.8406	0.8479	1.0006
7500	38	19	4.1149	0.9476	1.1003
8000	43	21.5	4.3892	1.0723	1.2250
8500	48	24	4.6635	1.1970	1.3497
9000	52	26	4.9379	1.2968	1.4495
9500	56	28	5.2122	1.3965	1.5492
10000	60	30	5.4865	1.4963	1.6490
10500	63	31.5	5.7608	1.5711	1.7238
11000	67	33.5	6.0352	1.6708	1.8235
11500	70	35	6.3095	1.7456	1.8983
12000	74	37	6.5838	1.8454	1.9981
12500	79	39.5	6.8581	1.9701	2.1228
13000	84	42	7.1325	2.0948	2.2475
13500	89	44.5	7.4068	2.2195	2.3722
14000	93	46.5	7.6811	2.3192	2.4719
14500	98	49	7.9554	2.4439	2.5966
15000	103	51.5	8.2298	2.5686	2.7213
15500	109	54.5	8.5041	2.7182	2.8709
16000	114	57	8.7784	2.8429	2.9956



UNIVERSITAS ATMA JAYA YOGYAKARTA
Fakultas Teknik Program Studi Teknik Sipil
Laboratorium Struktur dan Bahan Bangunan

Jl. Babarsari No.44 Yogyakarta 55281 Indonesia Kotak Pos 1086
Telp. +62-274-487711 (hunting) Fax. +62-274-487748

Lampiran 11
Halaman 137

16500	120	60	9.0528	2.9925	3.1452
17000	126	63	9.3271	3.1421	3.2948
17500	131	65.5	9.6014	3.2668	3.4195
18000	138	69	9.8757	3.4414	3.5941
18500	145	72.5	10.1501	3.6160	3.7687
19000	152	76	10.4244	3.7905	3.9432
19500	159	79.5	10.6987	3.9651	4.1178



DOKUMENTASI PENELITIAN



Pengujian berat jenis agregat kasar



Pengujian agregat halus



Pengujian *slump flow*



Pengujian *L-Shape box*



Beton yang sudah dituang ke bekisting

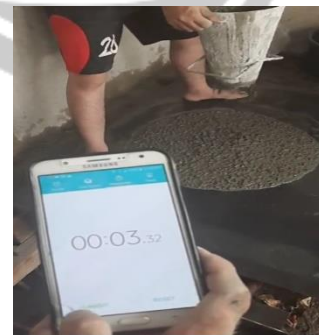

Pengujian *T500 Slumpflow*



Pengujian *modulus of rupture*



Pengujian modulus elastisitas



Pengujian kuat tekan beton



Pengujian kuat tarik belah beton

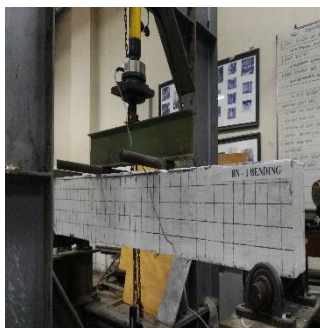

Pengujian kapasitas balok



Proses penempatan balok pada loading frame