

BAB V

KESIMPULAN

Pada bab ini akan dijelaskan mengenai kesimpulan dari hasil penelitian yang sudah dilakukan. Dalam bab ini juga akan dipaparkan mengenai keterbatasan penelitian, serta saran.

5. Kesimpulan

Berdasarkan analisis dari hasil perhitungan menggunakan metode PERT dapat disimpulkan bahwa :

1. Terdapat 15 aktifitas jalur kritis dengan total 318 hari waktu yang diharapkan (te).
2. Dengan menggunakan PERT, angka kemungkinan mencapai target “Z” adalah 0.59. Dengan menggunakan kurva distribusi normal / tabel kumulative Z didapatkan probabilitas sebesar 0,72240 atau 72,24%. Hal ini menunjukkan bahwa kemungkinan tercapainya finishing per lantai pada target 321 hari adalah 72,24%.

5.1 Keterbatasan penelitian

Dalam penelitian ini, penulis menyadari bahwa masih ada beberapa keterbatasan dalam penulisan yaitu:

1. Penelitian ini dilakukan dalam satu proyek sehingga hasil dari penelitian tidak berlaku untuk proyek yang lain atau berlaku secara umum, karena perbedaan aspek-aspek pendukung seperti aktifitas, jalur kritis, *predecessor* dan besarnya proyek.

2. Penulis menerima perencanaan / *schedule* dari konsultan sehingga tidak menjamin pelaksanaan dari setiap kontraktor sesuai perencanaan.
 3. Adanya kesalahan *Predecessor* pada lantai satu dan dua dimana lantai satu akan star setelah lantai 16 dan lantai 2 akan start setelah lantai 17. Dalam peneletian ini telah di ubah sebagai mana mestinya dengan ijin dari *General Manager* proyek yaitu pemberi data PT. Jaya CM.
 4. Adanya kesalahan data pada finis tiap lantai yaitu durasi finis lantai adalah 0 hari. Dengan konsultasi terhadap *General Manager* bahwa finis tiap lantai memiliki durasi satu hari sehingga mengubah target perlintai dari 320 hari menjadi 321 hari, target tower dari 420 hari perencanaan menjadi 436 hari perencanaan.
 5. Data perencanaan dibuat Konsultan pengawas hanya dengan kurva S dari kontraktor sehingga tidak memiliki probabilitas pencapaian target sehingga beberapa kontraktor melakukan beberapa kali revisi jadwal
- lampiran 28.**
6. Penulis tidak dapat menganalisis untuk percepatan proyek karena waktu dan besaran biaya seperti bahan, upah, jam kerja dan biaya lainnya berbeda tiap kontraktor. Data tersebut tidak didapatkan penulis dari konsultan pengawas yang membuat perencanaan.

5.2 Saran

Berdasarkan peneletian, maka penulis memberikan beberapa saran :

Bagi Perusahaan

1. Perusahaan atau dalam hal ini pembuat perencanaan keseluruhan (konsultan pengawas) sudah sebaiknya menggunakan analisis PERT sehingga akan memiliki probabilitas dalam target dan memiliki waktu untuk menganalisis percepatan proyek manakala ada kemunduran.
2. Perusahaan atau dalam hal ini pembuat perencanaan keseluruhan (konsultan pengawas) diharapkan membuat perencanaan dengan *predecessor* yang lebih jelas sehingga tidak mengurangi keakuratan dalam menghitung Probabilitas.
3. Perusahaan atau dalam hal ini pembuat perencanaan keseluruhan (konsultan pengawas) harusnya saling konsultasi dengan kontraktor dalam pembuatan perencanaan sehingga tidak mengakibatkan adanya kesalahan antar aktifitas.
4. Perlunya pengendalian waktu sejak dini dalam mengantisipasi waktu penyelesaian proyek agar tidak mengalami keterlambatan.

Bagi Penelitian selanjutnya

1. Peneliti selanjutnya diharapkan dapat membuat perencanaan yang lebih baik sehingga tidak mengakibatkan berkurangnya keakuratan probabilitas proyek.
2. Untuk penelitian selanjutnya diharapkan memperluas lagi dengan menggunakan metode yang lain yang tidak dipakai dalam penelitian ini sehingga dapat dijadikan pembandingan.

DAFTAR PUSTAKA

- Adedeji, A, A., dan Bello, A, J. (2011). “Construction Procedure of A Straw Bale Walled Building –A Review”. *International Journal Of Engineering*, Tome IX Fascicule3: 255-262.
- Adegoke, S, A. (June 2011). “Measuring Process Effectiveness Using Cpm/Pert”. *International Journal of Business and Management*, 6 (6): 286-295. Alfabeta Bumi Aksara, 2013
- Alifen, R. S, Setiawan, R. S, Sunarto, A. 2000. Analisa “What If” Sebagai Metode Antisipasi Keterlambatan Durasi Proyek, *Dimensi Teknik Sipil, Vol. 2 No. 1, Maret*.
- Heizer, J., dan Render, B. (2014). *Operation Management: Sustainability and supply Chain Management*, Eleven Edition. PEARSON.
- Herjanto, E. (2007). *Manajemen Operasi*, edisi 3. Jakarta: PT. Gramedia
- Indri Meliasari., M. Indrayadi., Lusiana (2013) “Earned Value Analysis Terhadap Biaya dan Waktu Pada Proyek Konstruksi” *Dimensi Teknik Sipil, Vol. 2*
- Khan, B, M. (January 2014). “ Impact of Total Quality Management on Performance of Project Management Firms: A case on Construction Firms of Pakistan”. *Interdisciplinary Journal Of Contemporary Research In Business*, 5 (9): 206-213.

Muhkherjee, S., dan Basu, K. (2011). “ solution of interval PERT/CPM network problem by a simplified tabular method”. *Opsearch*, 48 (4): 355-370

Nwackhukwu, C, C., dan Emoh, I, F. (2010). “Project Management Indexes: A Policy thrust To The Realization Of Vision 2020 In Housing Construction and Development In Negeria”. *Interdisciplinary Journal Of Contemporary Research In Busines*, 2 (7): 37-60

P M Wale , N D. Jain , N R Godhani , S R Beniwal , A A Mir2 (2015) “Planning and Scheduling of Project using Microsoft Project (Case Study of a building in India)”. *IOSR Journal of Mechanical and Civil Engineering (IOSR-JMCE)* Volume 12, Issue 3 Ver. III (May. - Jun. 2015), PP 57-63

Project Management Institute. (2013). *A Guide to the Project Management Body of Knowledge (PMBOK guide) Fifth Edition*. Newtown Square, Pennsylvania: 14 Campus Boulevard.

Sanket Borse, Prof Mrs. Arjita P Biswas (2016). “Schedule Forecasting Of Project Using EVM and PERT” *International Research Journal of Engineering and Technology (IRJET)* Volume: 03 Issue: 05

Shubham Laddha , Prerna Chanda and Sneha Khedekar (2017) “PLANNING AND SCHEDULING OF A PROJECT USING MICROSOFT PROJECT

(MSP).

INTERNATIONAL JOURNAL OF ADVANCED RESEARCH (IJAR) Int. J.

Adv. Res. 5(6), 161-168

Xu, J., dan Zhang, Z. (2012). "A fuzzy random resource-constrained scheduling model with multiple projects and its application to a working procedure in a large-scale water conservancy and hydropower construction project". *Springer Science + Business Media, LLC 2010, 15:253–272.*

Yair, B, A., Laslo, Z., dan Greenberg, D. (2008). "Time-Cost Optimization Model For Deterministic Network Projects". *Journal of Applied Quantitative Methods, 3 (4):339-351.*

LAMPIRAN

Lampiran 1. Surat Keterangan Penelitian



PROYEK PEMBANGUNAN PODOMORO CITY DELI MEDAN

SURAT KETERANGAN KERJA PRAKTEK

No. 009/PCDM-RT/SKKP/XI/2018

Yang bertanda tangan di bawah ini:

NAMA : **Ir. RONALD TOGATOROP, MT, PMP, M. ASCE**
JABATAN : CONSTRUCTION MANAGER
PROYEK PEMBANGUNAN PODOMORO CITY DELI
MEDAN

Menerangkan bahwa:

NAMA : **JAN ROYCAN DAMANIK**
NIM : 21655
PROGRAM STUDI : Manajemen
UNIVERSITAS : Universitas Atma Jaya Yogyakarta
Jl. Babarsari No. 43 Yogyakarta - 55281.
Telp. +62-274-487711, Fax. +62-274-485227
Web : //www.uajy.ac.id

Telah kerja praktek pada,

PEKERJAAN : MANAJEMEN KONSTRUKSI PEMBANGUNAN
PODOMORO CITY DELI MEDAN
MASA KERJA PRAKTEK : 12 Nopember 2018 s/d 14 Nopember 2018
LOKASI PEKERJAAN : Jl. Putri Hijau No.1 OPQ Kel. Kesawan Kec. Medan Barat
Kota Medan – Sumatera Utara

Bahwa selama bekerja praktek yang bersangkutan telah menjalankan tugas dan tanggung jawabnya dengan baik.

Demikian surat keterangan kerja ini dibuat untuk dipergunakan seperlunya.

Medan, 14 Nopember 2018

PT. JAYA CM
PROYEK PEMBANGUNAN
PODOMORO CITY DELI MEDAN



Ir. Ronald Togatorop, MT, PMP, M. ASCE
Construction Manager

Lampiran 2. Project Progress



Gambar 1 Tower 3L



. Gambar 2. Taman 3L



Gambar 3. *Project Progress*



Gambar 4. Rencana Hasil Akhir

Lampiran 3. Daftar Aktivitas, *Network Planning, Predecessor* Lantai 1

PEMILIK		COMPOSITE SCHEDULE					KONSULTAN MK				
PODO MORO CITY DELI MEGAN		FINISHING-ME TOWER 3L					JAYA CM				
ID	Task Name	Duration	Start	Finish	Predecessors	Critical	2017		2018		2019
							H1	H2	H1	H2	H1
1	SCHEDULE FINISHING-ME TOWER 3L	321 days	Mon 1/1/18	Sat 11/17/18		Yes					
2	LINCOLN (Lantai LM)	321 days	Mon 1/1/18	Sat 11/17/18		Yes					
3	LANTAI 1	321 days	Mon 1/1/18	Sat 11/17/18		Yes					
4	AREA UNIT	285 days	Mon 1/1/18	Fri 10/12/18		Yes					
5	MARKING	15 days	Mon 1/1/18	Mon 1/15/18		Yes					
6	PEKERJAAN DINDING	270 days	Tue 1/16/18	Fri 10/12/18		Yes					
7	PASANG BATA	30 days	Tue 1/16/18	Wed 2/14/18	5	Yes					
8	PLESTER/RENDER	30 days	Sat 3/17/18	Sun 4/15/18	7,11,12,13	No					
9	CAT DINDING	30 days	Mon 4/16/18	Tue 5/15/18	8	No					
10	MEP DINDING	240 days	Thu 2/15/18	Fri 10/12/18		No					
11	ELEKTRONIK	30 days	Thu 2/15/18	Fri 3/16/18	7	No					
12	ELEKTRIKAL	30 days	Thu 2/15/18	Fri 3/16/18	7	No					
13	MVAC	30 days	Thu 2/15/18	Fri 3/16/18	7	No					
14	FIXTURES MEP DALAM DINDING	30 days	Thu 9/13/18	Fri 10/12/18	11,12,13,18,19	No					
15	TEST MEP	30 days	Sat 3/17/18	Sun 4/15/18	11,12,13	No					
16	PINTU KAYU	60 days	Sun 7/15/18	Wed 9/12/18		No					
17	KUSEN PINTU	30 days	Sun 7/15/18	Mon 8/13/18	8,21	No					
18	DAUN PINTU	30 days	Sun 7/15/18	Mon 8/13/18	9FF,17SS	No					
19	ACESSORIES	30 days	Tue 8/14/18	Wed 9/12/18	18	No					
20	PEKERJAAN LANTAI	44 days	Fri 6/15/18	Sat 7/28/18		No					
21	PASANG MARBEL	30 days	Fri 6/15/18	Sat 7/14/18	25	No					
22	POLES MARBEL	30 days	Fri 6/29/18	Sat 7/28/18	21SS+14 days	No					
23	PEKERJAAN PLAFOND	240 days	Thu 2/15/18	Fri 10/12/18		No					
24	PASANG RANGKA	30 days	Mon 4/16/18	Tue 5/15/18	8,29,32	No					
25	TUTUP PLAFOND	30 days	Wed 5/16/18	Thu 6/14/18	24,34	No					

ID	Task Name	Duration	Start	Finish	Predecessors	Critical	2017		2018		2019
							H1	H2	H1	H2	H1
26	COMPOUND	30 days	Fri 6/15/18	Sat 7/14/18	25	No					
27	CAT PLAFOND	30 days	Sun 7/15/18	Mon 8/13/18	26	No					
28	MEP DALAM PLAFOND	240 days	Thu 2/15/18	Fri 10/12/18		No					
29	ELEKTRIKAL	30 days	Thu 2/15/18	Fri 3/16/18	7,12SS	No					
30	ELEKTRONIK	30 days	Thu 2/15/18	Fri 3/16/18	7,11SS	No					
31	MVAC	30 days	Thu 2/15/18	Fri 3/16/18	7,13SS	No					
32	PLPK	30 days	Thu 2/15/18	Fri 3/16/18	7	No					
33	FIXTURE MEP DALAM PLAFOND	30 days	Thu 9/13/18	Fri 10/12/18	19,25,29,30,31,32	No					
34	TEST MEP	30 days	Sat 3/17/18	Sun 4/15/18	29,30,31,32	No					
35	AREA KAMAR MANDI	275 days	Thu 2/15/18	Fri 11/16/18		Yes					
36	CORING	20 days	Thu 2/15/18	Tue 3/6/18	7	Yes					
37	PASANG PIPA	25 days	Wed 3/7/18	Sat 3/31/18	36	Yes					
38	TEST BOCOR	20 days	Sun 4/1/18	Fri 4/20/18	37	Yes					
39	GROUTING	25 days	Sat 4/21/18	Tue 5/15/18	38	Yes					
40	PASANG HT DINDING	25 days	Sat 6/30/18	Tue 7/24/18	7SS,38,42	Yes					
41	WATER PROOFING	25 days	Wed 5/16/18	Sat 6/9/18	39	Yes					
42	TEST WATER PROOFING	20 days	Sun 6/10/18	Fri 6/29/18	41	Yes					
43	PASANG HT LANTAI	25 days	Thu 9/13/18	Sun 10/7/18	40,42,45	Yes					
44	PASANG RANGKA PLAFOND	25 days	Wed 7/25/18	Sat 8/18/18	40	Yes					
45	TUTUP PLAFOND	25 days	Sun 8/19/18	Wed 9/12/18	44	Yes					
46	CAT PLAFOND	25 days	Thu 9/13/18	Sun 10/7/18	27FF,45	No					
47	PASANG PINTU	20 days	Mon 10/8/18	Sat 10/27/18	8,15,43	Yes					
48	PASANG SANITARY	20 days	Sun 10/28/18	Fri 11/16/18	19,47	Yes					
49	AREA FAÇADE/BALKON	125 days	Tue 1/16/18	Sun 5/20/18		No					

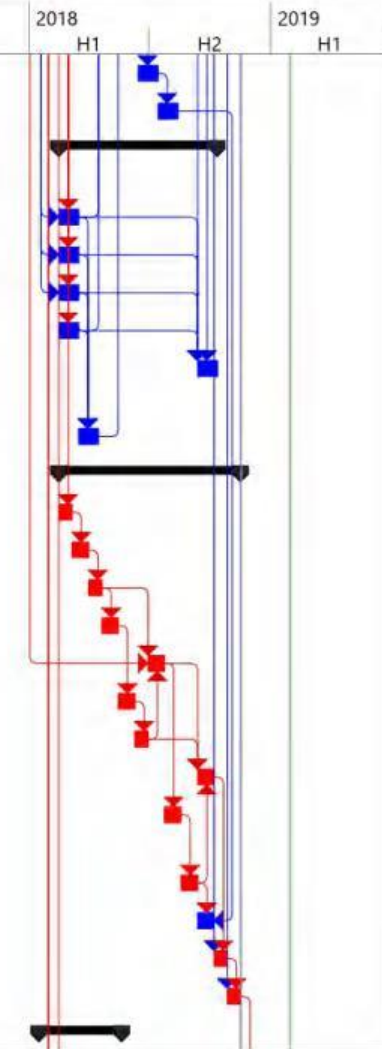

ID	Task Name	Duration	Start	Finish	Predecessors	Critical	2017		2018		2019
							H1	H2	H1	H2	H1
50	PASANG PC PANEL	25 days	Tue 1/16/18	Fri 2/9/18	5	No					
51	PASANG JENDELA ALUMUNIU	25 days	Sat 2/10/18	Tue 3/6/18	50	No					
52	PASANG RAILING BALKON	30 days	Sat 2/10/18	Sun 3/11/18	50	No					
53	PASANG HT LANTAI	25 days	Thu 4/26/18	Sun 5/20/18	55	No					
54	WATER PROOFING	25 days	Mon 3/12/18	Thu 4/5/18	52	No					
55	TEST WATER PROOFING	20 days	Fri 4/6/18	Wed 4/25/18	54	No					
56	AREA CORIDOR	245.5 days	Tue 1/16/18	Tue 9/18/18		No					
57	Pasang Bata	25 days	Thu 2/15/18	Sun 3/11/18	5FS+30 days	No					
58	Pasang Conduit + Inbodur di Dinding	25 days	Tue 2/27/18	Sat 3/24/18	57SS+50%	No					
59	Pasang Conduit di Plafond	25 days	Tue 2/27/18	Sat 3/24/18	58SS	No					
60	Render/Plaster	25 days	Mon 3/12/18	Thu 4/5/18	58SS+50%	No					
61	Instalasi Kabel	25 days	Sun 3/4/18	Thu 3/29/18	59SS+5 days	No					
62	Instalasi MVAC	25 days	Sun 3/4/18	Thu 3/29/18	59SS+5 days	No					
63	Pipa Fire Fighting	25 days	Tue 1/16/18	Fri 2/9/18	5	No					
64	Test Parsial MEP dalam Plafond	20 days	Mon 4/23/18	Sun 5/13/18	65	No					
65	Rangka Plafond	25 days	Thu 3/29/18	Mon 4/23/18	61,62,63	No					
66	Tutup Plafond	25 days	Wed 5/16/18	Sun 6/10/18	64FS+3 days	No					
67	Pasang HT/Keramik	25 days	Sun 6/10/18	Thu 7/5/18	66	No					
68	Railing Tangga	25 days	Mon 3/12/18	Thu 4/5/18	57	No					
69	ME Fixture di Plafond	25 days	Mon 7/30/18	Fri 8/24/18	66,71	No					
70	ME Fixture di Dinding	25 days	Mon 7/30/18	Fri 8/24/18	69SS,71	No					
71	Pintu Besi	25 days	Thu 7/5/18	Mon 7/30/18	67	No					

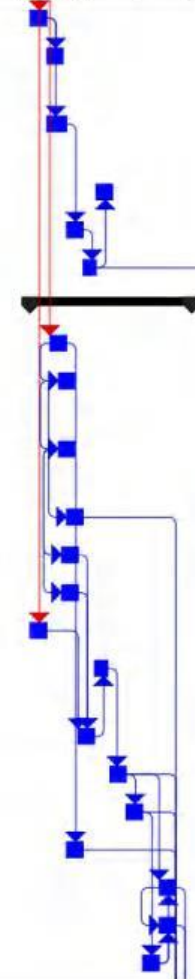

ID	Task Name	Duration	Start	Finish	Predecessors	Critical	2017		2018		2019	
							H1	H2	H1	H2	H1	H2
72	Pengecatan	25 days	Fri 8/24/18	Tue 9/18/18	60,66,67,68,69,70	No						
73	Finish Lantai 1	1 day	Sat 11/17/18	Sat 11/17/18	22,48,55,72	Yes						



Lampiran 4. Daftar Aktivitas, *Network Planning, Predecessor* Lantai 2

PEMILIK		COMPOSITE SCHEDULE					KONSULTAN MK				
PODO MORO CITY		FINISHING-ME TOWER 3L					JAYA CM				
ID	Task Name	Duration	Start	Finish	Predecessors	Critical	2017	2018	2019		
							H1	H2	H1	H2	H1
1	SCHEDULE FINISHING-ME TOWER 3L	326 days	Mon 1/1/18	Thu 11/22/18		Yes					
2	LINCOLN (Lantai LM)	326 days	Mon 1/1/18	Thu 11/22/18		Yes					
3	LANTAI 1	321 days	Mon 1/1/18	Sat 11/17/18		No					
74	LANTAI 2	321 days	Sat 1/6/18	Thu 11/22/18	3SS+5 days	Yes					
75	AREA UNIT	285 days	Sat 1/6/18	Wed 10/17/18		Yes					
76	MARKING	15 days	Sat 1/6/18	Sat 1/20/18		Yes					
77	PEKERJAAN DINDING	270 days	Sun 1/21/18	Wed 10/17/18		Yes					
78	PASANG BATA	30 days	Sun 1/21/18	Mon 2/19/18	76	Yes					
79	PLESTER/RENDER	30 days	Thu 3/22/18	Fri 4/20/18	78,82,83,84	No					
80	CAT DINDING	30 days	Sat 4/21/18	Sun 5/20/18	79	No					
81	MEP DINDING	240 days	Tue 2/20/18	Wed 10/17/18		No					
82	ELEKTRONIK	30 days	Tue 2/20/18	Wed 3/21/18	78	No					
83	ELEKTRIKAL	30 days	Tue 2/20/18	Wed 3/21/18	78	No					
84	MVAC	30 days	Tue 2/20/18	Wed 3/21/18	78	No					
85	FIXTURES MEP DALAM DINDING	30 days	Tue 9/18/18	Wed 10/17/18	82,83,84,89,90	No					
86	TEST MEP	30 days	Thu 3/22/18	Fri 4/20/18	82,83,84	No					
87	PINTU KAYU	60 days	Fri 7/20/18	Mon 9/17/18		No					
88	KUSEN PINTU	30 days	Fri 7/20/18	Sat 8/18/18	79,92	No					
89	DAUN PINTU	30 days	Fri 7/20/18	Sat 8/18/18	80FF,88SS	No					
90	ACESSORIES	30 days	Sun 8/19/18	Mon 9/17/18	89	No					
91	PEKERJAAN LANTAI	44 days	Wed 6/20/18	Thu 8/2/18		No					
92	PASANG MARBEL	30 days	Wed 6/20/18	Thu 7/19/18	96	No					
93	POLES MARBEL	30 days	Wed 7/4/18	Thu 8/2/18	92SS+14 days	No					
94	PEKERJAAN PLAFOND	240 days	Tue 2/20/18	Wed 10/17/18		No					
95	PASANG RANGKA	30 days	Sat 4/21/18	Sun 5/20/18	79,100,103	No					

ID	Task Name	Duration	Start	Finish	Predecessors	Critical	2017		2018		2019
							H1	H2	H1	H2	H1
96	TUTUP PLAFOND	30 days	Mon 5/21/18	Tue 6/19/18	95,105	No					
97	COMPOUND	30 days	Wed 6/20/18	Thu 7/19/18	96	No					
98	CAT PLAFOND	30 days	Fri 7/20/18	Sat 8/18/18	97	No					
99	MEP DALAM PLAFOND	240 days	Tue 2/20/18	Wed 10/17/18		No					
100	ELEKTRIKAL	30 days	Tue 2/20/18	Wed 3/21/18	78,83SS	No					
101	ELEKTRONIK	30 days	Tue 2/20/18	Wed 3/21/18	78,82SS	No					
102	MVAC	30 days	Tue 2/20/18	Wed 3/21/18	78,84SS	No					
103	PLPK	30 days	Tue 2/20/18	Wed 3/21/18	78	No					
104	FIXTURE MEP DALAM PLAFOND	30 days	Tue 9/18/18	Wed 10/17/18	90,96,100,101,102,	No					
105	TEST MEP	30 days	Thu 3/22/18	Fri 4/20/18	100,101,102,103	No					
106	AREA KAMAR MANDI	275 days	Tue 2/20/18	Wed 11/21/18		Yes					
107	CORING	20 days	Tue 2/20/18	Sun 3/11/18	78	Yes					
108	PASANG PIPA	25 days	Mon 3/12/18	Thu 4/5/18	107	Yes					
109	TEST BOCOR	20 days	Fri 4/6/18	Wed 4/25/18	108	Yes					
110	GROUTING	25 days	Thu 4/26/18	Sun 5/20/18	109	Yes					
111	PASANG HT DINDING	25 days	Thu 7/5/18	Sun 7/29/18	78SS,109,113	Yes					
112	WATER PROOFING	25 days	Mon 5/21/18	Thu 6/14/18	110	Yes					
113	TEST WATER PROOFING	20 days	Fri 6/15/18	Wed 7/4/18	112	Yes					
114	PASANG HT LANTAI	25 days	Tue 9/18/18	Fri 10/12/18	111,113,116	Yes					
115	PASANG RANGKA PLAFOND	25 days	Mon 7/30/18	Thu 8/23/18	111	Yes					
116	TUTUP PLAFOND	25 days	Fri 8/24/18	Mon 9/17/18	115	Yes					
117	CAT PLAFOND	25 days	Tue 9/18/18	Fri 10/12/18	98FF,116	No					
118	PASANG PINTU	20 days	Sat 10/13/18	Thu 11/1/18	79,86,114	Yes					
119	PASANG SANITARY	20 days	Fri 11/2/18	Wed 11/21/18	90,118	Yes					

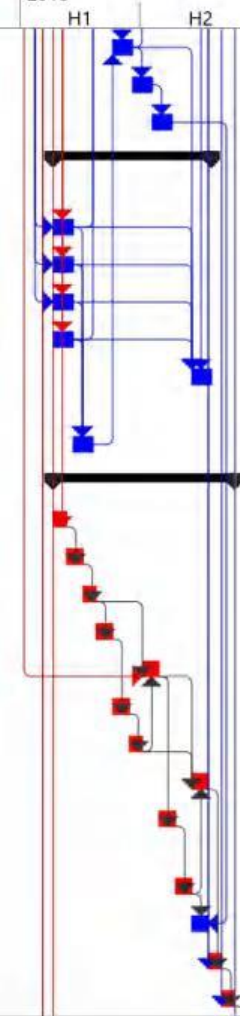

ID	Task Name	Duration	Start	Finish	Predecessors	Critical	2017		2018		2019
							H1	H2	H1	H2	H1
120	AREA FAÇADE/BALKON	125 days	Sun 1/21/18	Fri 5/25/18		No					
121	PASANG PC PANEL	25 days	Sun 1/21/18	Wed 2/14/18	76	No					
122	PASANG JENDELA ALUMUNIUM	25 days	Thu 2/15/18	Sun 3/11/18	121	No					
123	PASANG RAILING BALKON	30 days	Thu 2/15/18	Fri 3/16/18	121	No					
124	PASANG HT LANTAI	25 days	Tue 5/1/18	Fri 5/25/18	126	No					
125	WATER PROOFING	25 days	Sat 3/17/18	Tue 4/10/18	123	No					
126	TEST WATER PROOFING	20 days	Wed 4/11/18	Mon 4/30/18	125	No					
127	AREA CORIDOR	245.5 days	Sun 1/21/18	Sun 9/23/18		No					
128	Pasang Bata	25 days	Tue 2/20/18	Fri 3/16/18	76FS+30 days	No					
129	Pasang Conduit + Inbodus di Dinding	25 days	Sun 3/4/18	Thu 3/29/18	128SS+50%	No					
130	Pasang Conduit di Plafond	25 days	Sun 3/4/18	Thu 3/29/18	129SS	No					
131	Render/Plaster	25 days	Sat 3/17/18	Tue 4/10/18	129SS+50%	No					
132	Instalasi Kabel	25 days	Fri 3/9/18	Tue 4/3/18	130SS+5 days	No					
133	Instalasi MVAC	25 days	Fri 3/9/18	Tue 4/3/18	130SS+5 days	No					
134	Pipa Fire Fighting	25 days	Sun 1/21/18	Wed 2/14/18	76	No					
135	Test Parsial MEP dalam Plafond	20 days	Sat 4/28/18	Fri 5/18/18	136	No					
136	Rangka Plafond	25 days	Tue 4/3/18	Sat 4/28/18	132,133,134	No					
137	Tutup Plafond	25 days	Mon 5/21/18	Fri 6/15/18	135FS+3 days	No					
138	Pasang HT/Keramik	25 days	Fri 6/15/18	Tue 7/10/18	137	No					
139	Railing Tangga	25 days	Sat 3/17/18	Tue 4/10/18	128	No					
140	ME Fixture di Plafond	25 days	Sat 8/4/18	Wed 8/29/18	137,142	No					
141	ME Fixture di Dinding	25 days	Sat 8/4/18	Wed 8/29/18	140SS,142	No					

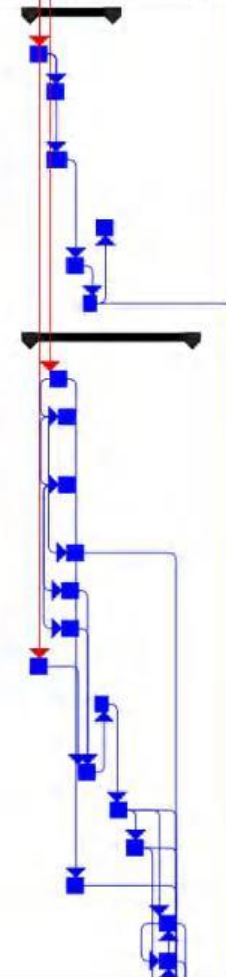

ID	Task Name	Duration	Start	Finish	Predecessors	Critical	2017		2018		2019	
							H1	H2	H1	H2	H1	H2
142	Pintu Besi	25 days	Tue 7/10/18	Sat 8/4/18	138	No						
143	Pengecatan	25 days	Wed 8/29/18	Sun 9/23/18	131,137,138,139,14	No						
144	Finish Lantai 2	1 day	Thu 11/22/18	Thu 11/22/18	93,119,126,143	Yes						

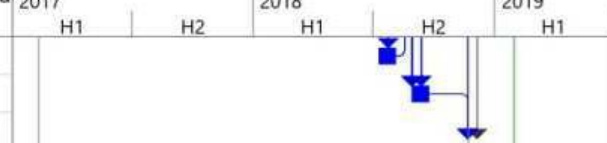

Lampiran 5. Daftar Aktivitas, *Network Planning*, Predecessor Lantai 3

PEMILIK		COMPOSITE SCHEDULE					KONSULTAN MK				
PODO MORO CITY DELI MEGAH		FINISHING-ME TOWER 3L					JAYA CM				
ID	Task Name	Duration	Start	Finish	Predecessors	Critical	2017		2018		2019
							H1	H2	H1	H2	H1
1	SCHEDULE FINISHING-ME TOWER 3L	331 days	Mon 1/1/18	Tue 11/27/18		Yes					
2	LINCOLN (Lantai LM)	331 days	Mon 1/1/18	Tue 11/27/18		Yes					
3	LANTAI 1	321 days	Mon 1/1/18	Sat 11/17/18		No					
74	LANTAI 2	321 days	Sat 1/6/18	Thu 11/22/18	3SS+5 days	No					
145	LANTAI 3	321 days	Thu 1/11/18	Tue 11/27/18	74SS+5 days	Yes					
146	AREA UNIT	285 days	Thu 1/11/18	Mon 10/22/18		Yes					
147	MARKING	15 days	Thu 1/11/18	Thu 1/25/18		Yes					
148	PEKERJAAN DINDING	270 days	Fri 1/26/18	Mon 10/22/18		Yes					
149	PASANG BATA	30 days	Fri 1/26/18	Sat 2/24/18	147	Yes					
150	PLESTER/RENDER	30 days	Tue 3/27/18	Wed 4/25/18	149,153,154,155	No					
151	CAT DINDING	30 days	Thu 4/26/18	Fri 5/25/18	150	No					
152	MEP DINDING	240 days	Sun 2/25/18	Mon 10/22/18		No					
153	ELEKTRONIK	30 days	Sun 2/25/18	Mon 3/26/18	149	No					
154	ELEKTRIKAL	30 days	Sun 2/25/18	Mon 3/26/18	149	No					
155	MVAC	30 days	Sun 2/25/18	Mon 3/26/18	149	No					
156	FIXTURES MEP DALAM DINDING	30 days	Sun 9/23/18	Mon 10/22/18	153,154,155,160,16	No					
157	TEST MEP	30 days	Tue 3/27/18	Wed 4/25/18	153,154,155	No					
158	PINTU KAYU	60 days	Wed 7/25/18	Sat 9/22/18		No					
159	KUSEN PINTU	30 days	Wed 7/25/18	Thu 8/23/18	150,163	No					
160	DAUN PINTU	30 days	Wed 7/25/18	Thu 8/23/18	151FF,159SS	No					
161	ACESSORIES	30 days	Fri 8/24/18	Sat 9/22/18	160	No					
162	PEKERJAAN LANTAI	44 days	Mon 6/25/18	Tue 8/7/18		No					
163	PASANG MARBEL	30 days	Mon 6/25/18	Tue 7/24/18	167	No					
164	POLES MARBEL	30 days	Mon 7/9/18	Tue 8/7/18	163SS+14 days	No					
165	PEKERJAAN PLAFOND	240 days	Sun 2/25/18	Mon 10/22/18		No					

ID	Task Name	Duration	Start	Finish	Predecessors	Critical	2017		2018		2019
							H1	H2	H1	H2	H1
166	PASANG RANGKA	30 days	Thu 4/26/18	Fri 5/25/18	150,171,174	No					
167	TUTUP PLAFOND	30 days	Sat 5/26/18	Sun 6/24/18	166,176	No					
168	COMPOUND	30 days	Mon 6/25/18	Tue 7/24/18	167	No					
169	CAT PLAFOND	30 days	Wed 7/25/18	Thu 8/23/18	168	No					
170	MEP DALAM PLAFOND	240 days	Sun 2/25/18	Mon 10/22/18		No					
171	ELEKTRIKAL	30 days	Sun 2/25/18	Mon 3/26/18	149,154SS	No					
172	ELEKTRONIK	30 days	Sun 2/25/18	Mon 3/26/18	149,153SS	No					
173	MVAC	30 days	Sun 2/25/18	Mon 3/26/18	149,155SS	No					
174	PLPK	30 days	Sun 2/25/18	Mon 3/26/18	149	No					
175	FIXTURE MEP DALAM PLAFOND	30 days	Sun 9/23/18	Mon 10/22/18	161,167,171,172,17	No					
176	TEST MEP	30 days	Tue 3/27/18	Wed 4/25/18	171,172,173,174	No					
177	AREA KAMAR MANDI	275 days	Sun 2/25/18	Mon 11/26/18		Yes					
178	CORING	20 days	Sun 2/25/18	Fri 3/16/18	149	Yes					
179	PASANG PIPA	25 days	Sat 3/17/18	Tue 4/10/18	178	Yes					
180	TEST BOCOR	20 days	Wed 4/11/18	Mon 4/30/18	179	Yes					
181	GROUTING	25 days	Tue 5/1/18	Fri 5/25/18	180	Yes					
182	PASANG HT DINDING	25 days	Tue 7/10/18	Fri 8/3/18	149SS,180,184	Yes					
183	WATER PROOFING	25 days	Sat 5/26/18	Tue 6/19/18	181	Yes					
184	TEST WATER PROOFING	20 days	Wed 6/20/18	Mon 7/9/18	183	Yes					
185	PASANG HT LANTAI	25 days	Sun 9/23/18	Wed 10/17/18	182,184,187	Yes					
186	PASANG RANGKA PLAFOND	25 days	Sat 8/4/18	Tue 8/28/18	182	Yes					
187	TUTUP PLAFOND	25 days	Wed 8/29/18	Sat 9/22/18	186	Yes					
188	CAT PLAFOND	25 days	Sun 9/23/18	Wed 10/17/18	169FF,187	No					
189	PASANG PINTU	20 days	Thu 10/18/18	Tue 11/6/18	150,157,185	Yes					

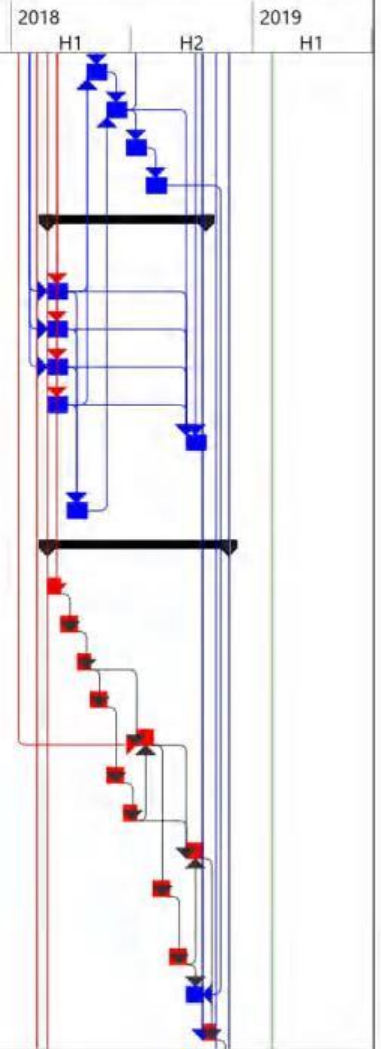

ID	Task Name	Duration	Start	Finish	Predecessors	Critical	2017		2018		2019
							H1	H2	H1	H2	H1
190	PASANG SANITARY	20 days	Wed 11/7/18	Mon 11/26/18	161,189	Yes					
191	AREA FAÇADE/BALKON	125 days	Fri 1/26/18	Wed 5/30/18		No					
192	PASANG PC PANEL	25 days	Fri 1/26/18	Mon 2/19/18	147	No					
193	PASANG JENDELA ALUMUNIUM	25 days	Tue 2/20/18	Fri 3/16/18	192	No					
194	PASANG RAILING BALKON	30 days	Tue 2/20/18	Wed 3/21/18	192	No					
195	PASANG HT LANTAI	25 days	Sun 5/6/18	Wed 5/30/18	197	No					
196	WATER PROOFING	25 days	Thu 3/22/18	Sun 4/15/18	194	No					
197	TEST WATER PROOFING	20 days	Mon 4/16/18	Sat 5/5/18	196	No					
198	AREA CORIDOR	245.5 days	Fri 1/26/18	Fri 9/28/18		No					
199	Pasang Bata	25 days	Sun 2/25/18	Wed 3/21/18	147FS+30 days	No					
200	Pasang Conduit + Inbodus di Dinding	25 days	Fri 3/9/18	Tue 4/3/18	199SS+50%	No					
201	Pasang Conduit di Plafond	25 days	Fri 3/9/18	Tue 4/3/18	200SS	No					
202	Render/Plaster	25 days	Thu 3/22/18	Sun 4/15/18	200SS+50%	No					
203	Instalasi Kabel	25 days	Wed 3/14/18	Sun 4/8/18	201SS+5 days	No					
204	Instalasi MVAC	25 days	Wed 3/14/18	Sun 4/8/18	201SS+5 days	No					
205	Pipa Fire Fighting	25 days	Fri 1/26/18	Mon 2/19/18	147	No					
206	Test Parsial MEP dalam Plafond	20 days	Thu 5/3/18	Wed 5/23/18	207	No					
207	Rangka Plafond	25 days	Sun 4/8/18	Thu 5/3/18	203,204,205	No					
208	Tutup Plafond	25 days	Sat 5/26/18	Wed 6/20/18	206FS+3 days	No					
209	Pasang HT/Keramik	25 days	Wed 6/20/18	Sun 7/15/18	208	No					
210	Railing Tangga	25 days	Thu 3/22/18	Sun 4/15/18	199	No					
211	ME Fixture di Plafond	25 days	Thu 8/9/18	Mon 9/3/18	208,213	No					

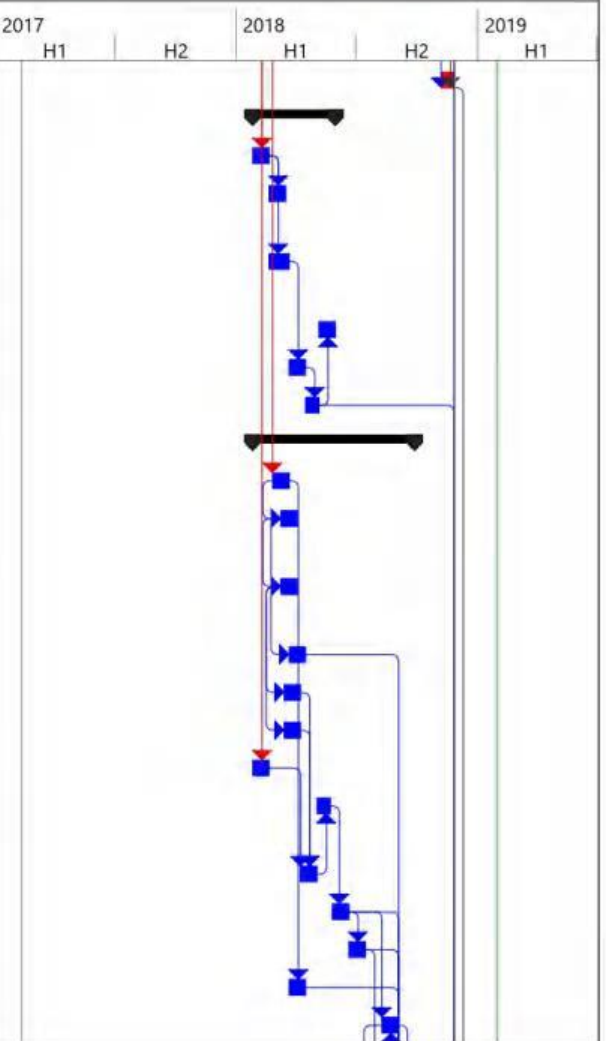

ID	Task Name	Duration	Start	Finish	Predecessors	Critical	2017		2018		2019	
							H1	H2	H1	H2	H1	H2
212	ME Fixture di Dinding	25 days	Thu 8/9/18	Mon 9/3/18	211SS,213	No						
213	Pintu Besi	25 days	Sun 7/15/18	Thu 8/9/18	209	No						
214	Pengecatan	25 days	Mon 9/3/18	Fri 9/28/18	202,208,209,210,211	No						
215	Finish Lantai 3	1 day	Tue 11/27/18	Tue 11/27/18	164,190,197,214	Yes						

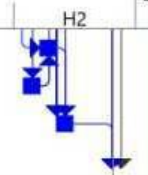

Lampiran 6. Daftar Aktivitas, *Network Planning, Predecessor* Lantai 5

PEMILIK		COMPOSITE SCHEDULE					KONSULTAN MK				
PODO MORO CITY		FINISHING-ME TOWER 3L					JAYA CM				
ID	Task Name	Duration	Start	Finish	Predecessors	Critical	2017	2018	2019		
							H1	H2	H1	H2	H1
1	SCHEDULE FINISHING-ME TOWER 3L	336 days	Mon 1/1/18	Sun 12/2/18		Yes					
2	LINCOLN (Lantai LM)	336 days	Mon 1/1/18	Sun 12/2/18		Yes					
3	LANTAI 1	321 days	Mon 1/1/18	Sat 11/17/18		No					
74	LANTAI 2	321 days	Sat 1/6/18	Thu 11/22/18	3SS+5 days	No					
145	LANTAI 3	321 days	Thu 1/11/18	Tue 11/27/18	74SS+5 days	No					
216	LANTAI 5	321 days	Tue 1/16/18	Sun 12/2/18	145SS+5 days	Yes					
217	AREA UNIT	285 days	Tue 1/16/18	Sat 10/27/18		Yes					
218	MARKING	15 days	Tue 1/16/18	Tue 1/30/18		Yes					
219	PEKERJAAN DINDING	270 days	Wed 1/31/18	Sat 10/27/18		Yes					
220	PASANG BATA	30 days	Wed 1/31/18	Thu 3/1/18	218	Yes					
221	PLESTER/RENDER	30 days	Sun 4/1/18	Mon 4/30/18	220,224,225,226	No					
222	CAT DINDING	30 days	Tue 5/1/18	Wed 5/30/18	221	No					
223	MEP DINDING	240 days	Fri 3/2/18	Sat 10/27/18		No					
224	ELEKTRONIK	30 days	Fri 3/2/18	Sat 3/31/18	220	No					
225	ELEKTRIKAL	30 days	Fri 3/2/18	Sat 3/31/18	220	No					
226	MVAC	30 days	Fri 3/2/18	Sat 3/31/18	220	No					
227	FIXTURES MEP DALAM DINDING	30 days	Fri 9/28/18	Sat 10/27/18	224,225,226,231,23	No					
228	TEST MEP	30 days	Sun 4/1/18	Mon 4/30/18	224,225,226	No					
229	PINTU KAYU	60 days	Mon 7/30/18	Thu 9/27/18		No					
230	KUSEN PINTU	30 days	Mon 7/30/18	Tue 8/28/18	221,234	No					
231	DAUN PINTU	30 days	Mon 7/30/18	Tue 8/28/18	222FF,230SS	No					
232	ACESSORIES	30 days	Wed 8/29/18	Thu 9/27/18	231	No					
233	PEKERJAAN LANTAI	44 days	Sat 6/30/18	Sun 8/12/18		No					
234	PASANG MARBEL	30 days	Sat 6/30/18	Sun 7/29/18	238	No					
235	POLES MARBEL	30 days	Sat 7/14/18	Sun 8/12/18	234SS+14 days	No					

ID	Task Name	Duration	Start	Finish	Predecessors	Critical	2017		2018		2019
							H1	H2	H1	H2	H1
236	PEKERJAAN PLAFOND	240 days	Fri 3/2/18	Sat 10/27/18		No					
237	PASANG RANGKA	30 days	Tue 5/1/18	Wed 5/30/18	221,242,245	No					
238	TUTUP PLAFOND	30 days	Thu 5/31/18	Fri 6/29/18	237,247	No					
239	COMPOUND	30 days	Sat 6/30/18	Sun 7/29/18	238	No					
240	CAT PLAFOND	30 days	Mon 7/30/18	Tue 8/28/18	239	No					
241	MEP DALAM PLAFOND	240 days	Fri 3/2/18	Sat 10/27/18		No					
242	ELEKTRIKAL	30 days	Fri 3/2/18	Sat 3/31/18	220,225SS	No					
243	ELEKTRONIK	30 days	Fri 3/2/18	Sat 3/31/18	220,224SS	No					
244	MVAC	30 days	Fri 3/2/18	Sat 3/31/18	220,226SS	No					
245	PLPK	30 days	Fri 3/2/18	Sat 3/31/18	220	No					
246	FIXTURE MEP DALAM PLAFOND	30 days	Fri 9/28/18	Sat 10/27/18	232,238,242,243,24	No					
247	TEST MEP	30 days	Sun 4/1/18	Mon 4/30/18	242,243,244,245	No					
248	AREA KAMAR MANDI	275 days	Fri 3/2/18	Sat 12/1/18		Yes					
249	CORING	20 days	Fri 3/2/18	Wed 3/21/18	220	Yes					
250	PASANG PIPA	25 days	Thu 3/22/18	Sun 4/15/18	249	Yes					
251	TEST BOCOR	20 days	Mon 4/16/18	Sat 5/5/18	250	Yes					
252	GROUTING	25 days	Sun 5/6/18	Wed 5/30/18	251	Yes					
253	PASANG HT DINDING	25 days	Sun 7/15/18	Wed 8/8/18	220SS,251,255	Yes					
254	WATER PROOFING	25 days	Thu 5/31/18	Sun 6/24/18	252	Yes					
255	TEST WATER PROOFING	20 days	Mon 6/25/18	Sat 7/14/18	254	Yes					
256	PASANG HT LANTAI	25 days	Fri 9/28/18	Mon 10/22/18	253,255,258	Yes					
257	PASANG RANGKA PLAFOND	25 days	Thu 8/9/18	Sun 9/2/18	253	Yes					
258	TUTUP PLAFOND	25 days	Mon 9/3/18	Thu 9/27/18	257	Yes					
259	CAT PLAFOND	25 days	Fri 9/28/18	Mon 10/22/18	240FF,258	No					

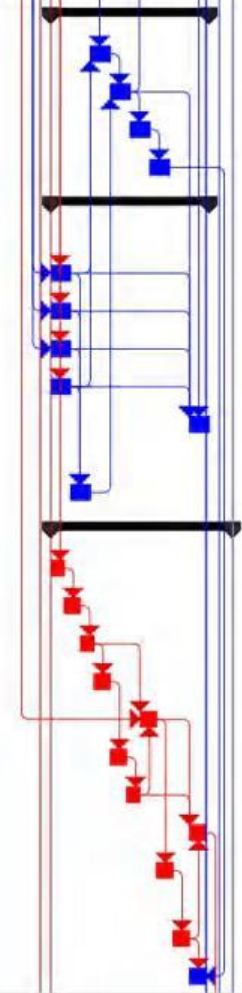

ID	Task Name	Duration	Start	Finish	Predecessors	Critical	2017		2018		2019
							H1	H2	H1	H2	H1
260	PASANG PINTU	20 days	Tue 10/23/18	Sun 11/11/18	221,228,256	Yes					
261	PASANG SANITARY	20 days	Mon 11/12/18	Sat 12/1/18	232,260	Yes					
262	AREA FAÇADE/BALKON	125 days	Wed 1/31/18	Mon 6/4/18		No					
263	PASANG PC PANEL	25 days	Wed 1/31/18	Sat 2/24/18	218	No					
264	PASANG JENDELA ALUMUNIUM	25 days	Sun 2/25/18	Wed 3/21/18	263	No					
265	PASANG RAILING BALKON	30 days	Sun 2/25/18	Mon 3/26/18	263	No					
266	PASANG HT LANTAI	25 days	Fri 5/11/18	Mon 6/4/18	268	No					
267	WATER PROOFING	25 days	Tue 3/27/18	Fri 4/20/18	265	No					
268	TEST WATER PROOFING	20 days	Sat 4/21/18	Thu 5/10/18	267	No					
269	AREA CORIDOR	245.5 days	Wed 1/31/18	Wed 10/3/18		No					
270	Pasang Bata	25 days	Fri 3/2/18	Mon 3/26/18	218FS+30 days	No					
271	Pasang Conduit + Inbodus di Dinding	25 days	Wed 3/14/18	Sun 4/8/18	270SS+50%	No					
272	Pasang Conduit di Plafond	25 days	Wed 3/14/18	Sun 4/8/18	271SS	No					
273	Render/Plaster	25 days	Tue 3/27/18	Fri 4/20/18	271SS+50%	No					
274	Instalasi Kabel	25 days	Mon 3/19/18	Fri 4/13/18	272SS+5 days	No					
275	Instalasi MVAC	25 days	Mon 3/19/18	Fri 4/13/18	272SS+5 days	No					
276	Pipa Fire Fighting	25 days	Wed 1/31/18	Sat 2/24/18	218	No					
277	Test Parsial MEP dalam Plafond	20 days	Tue 5/8/18	Mon 5/28/18	278	No					
278	Rangka Plafond	25 days	Fri 4/13/18	Tue 5/8/18	274,275,276	No					
279	Tutup Plafond	25 days	Thu 5/31/18	Mon 6/25/18	277FS+3 days	No					
280	Pasang HT/Keramik	25 days	Mon 6/25/18	Fri 7/20/18	279	No					
281	Railing Tangga	25 days	Tue 3/27/18	Fri 4/20/18	270	No					

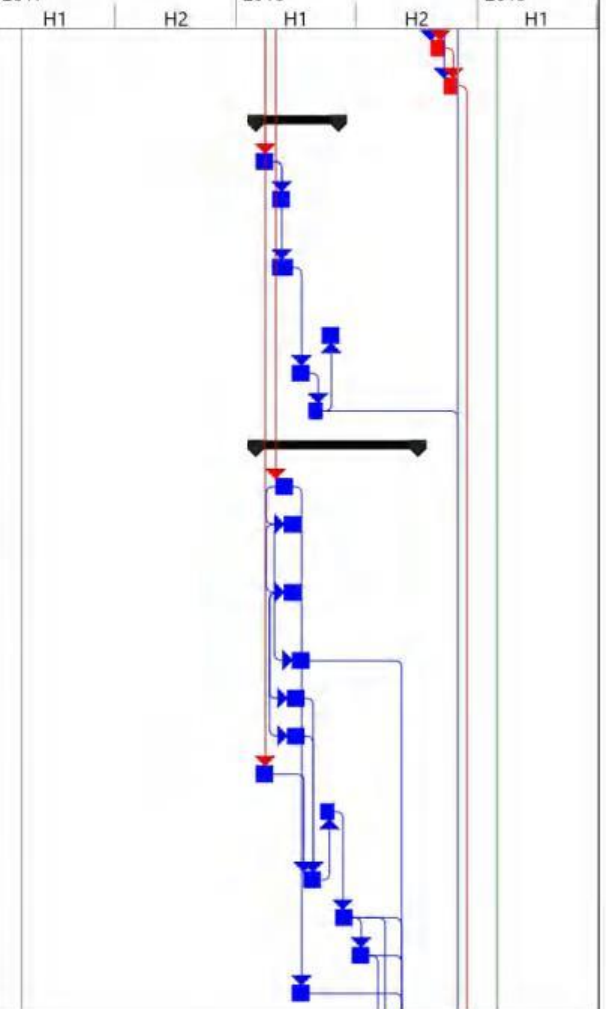

ID	Task Name	Duration	Start	Finish	Predecessors	Critical	2017		2018		2019
							H1	H2	H1	H2	H1
282	ME Fixture di Plafond	25 days	Tue 8/14/18	Sat 9/8/18	279,284	No					
283	ME Fixture di Dinding	25 days	Tue 8/14/18	Sat 9/8/18	282SS,284	No					
284	Pintu Besi	25 days	Fri 7/20/18	Tue 8/14/18	280	No					
285	Pengecatan	25 days	Sat 9/8/18	Wed 10/3/18	273,279,280,281,28	No					
286	Finish Lantai 5	1 day	Sun 12/2/18	Sun 12/2/18	235,261,268,285	Yes					

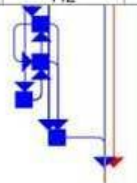

Lampiran 7. Daftar Aktivitas, *Network Planning, Predecessor* Lantai 6

PEMILIK		COMPOSITE SCHEDULE					KONSULTAN MK				
PODO MORO CITY DELI MEGAN		FINISHING-ME TOWER 3L					JAYA CM				
ID	Task Name	Duration	Start	Finish	Predecessors	Critical	2017	2018	2019		
							H1	H2	H1	H2	H1
1	SCHEDULE FINISHING-ME TOWER 3L	341 days	Mon 1/1/18	Fri 12/7/18		Yes					
2	LINCOLN (Lantai LM)	341 days	Mon 1/1/18	Fri 12/7/18		Yes					
3	LANTAI 1	321 days	Mon 1/1/18	Sat 11/17/18		No					
74	LANTAI 2	321 days	Sat 1/6/18	Thu 11/22/18	3SS+5 days	No					
145	LANTAI 3	321 days	Thu 1/11/18	Tue 11/27/18	74SS+5 days	No					
216	LANTAI 5	321 days	Tue 1/16/18	Sun 12/2/18	145SS+5 days	No					
287	LANTAI 6	321 days	Sun 1/21/18	Fri 12/7/18	216SS+5 days	Yes					
288	AREA UNIT	285 days	Sun 1/21/18	Thu 11/1/18		Yes					
289	MARKING	15 days	Sun 1/21/18	Sun 2/4/18		Yes					
290	PEKERJAAN DINDING	270 days	Mon 2/5/18	Thu 11/1/18		Yes					
291	PASANG BATA	30 days	Mon 2/5/18	Tue 3/6/18	289	Yes					
292	PLESTER/RENDER	30 days	Fri 4/6/18	Sat 5/5/18	291,295,296,297	No					
293	CAT DINDING	30 days	Sun 5/6/18	Mon 6/4/18	292	No					
294	MEP DINDING	240 days	Wed 3/7/18	Thu 11/1/18		No					
295	ELEKTRONIK	30 days	Wed 3/7/18	Thu 4/5/18	291	No					
296	ELEKTRIKAL	30 days	Wed 3/7/18	Thu 4/5/18	291	No					
297	MVAC	30 days	Wed 3/7/18	Thu 4/5/18	291	No					
298	FIXTURES MEP DALAM DINDING	30 days	Wed 10/3/18	Thu 11/1/18	295,296,297,302,30	No					
299	TEST MEP	30 days	Fri 4/6/18	Sat 5/5/18	295,296,297	No					
300	PINTU KAYU	60 days	Sat 8/4/18	Tue 10/2/18		No					
301	KUSEN PINTU	30 days	Sat 8/4/18	Sun 9/2/18	292,305	No					
302	DAUN PINTU	30 days	Sat 8/4/18	Sun 9/2/18	293FF,301SS	No					
303	ACESSORIES	30 days	Mon 9/3/18	Tue 10/2/18	302	No					
304	PEKERJAAN LANTAI	44 days	Thu 7/5/18	Fri 8/17/18		No					
305	PASANG MARBEL	30 days	Thu 7/5/18	Fri 8/3/18	309	No					

ID	Task Name	Duration	Start	Finish	Predecessors	Critical	2017		2018		2019
							H1	H2	H1	H2	H1
306	POLES MARBEL	30 days	Thu 7/19/18	Fri 8/17/18	305SS+14 days	No					
307	PEKERJAAN PLAFOND	240 days	Wed 3/7/18	Thu 11/1/18		No					
308	PASANG RANGKA	30 days	Sun 5/6/18	Mon 6/4/18	292,313,316	No					
309	TUTUP PLAFOND	30 days	Tue 6/5/18	Wed 7/4/18	308,318	No					
310	COMPOUND	30 days	Thu 7/5/18	Fri 8/3/18	309	No					
311	CAT PLAFOND	30 days	Sat 8/4/18	Sun 9/2/18	310	No					
312	MEP DALAM PLAFOND	240 days	Wed 3/7/18	Thu 11/1/18		No					
313	ELEKTRIKAL	30 days	Wed 3/7/18	Thu 4/5/18	291,296SS	No					
314	ELEKTRONIK	30 days	Wed 3/7/18	Thu 4/5/18	291,295SS	No					
315	MVAC	30 days	Wed 3/7/18	Thu 4/5/18	291,297SS	No					
316	PLPK	30 days	Wed 3/7/18	Thu 4/5/18	291	No					
317	FIXTURE MEP DALAM PLAFOND	30 days	Wed 10/3/18	Thu 11/1/18	303,309,313,314,31	No					
318	TEST MEP	30 days	Fri 4/6/18	Sat 5/5/18	313,314,315,316	No					
319	AREA KAMAR MANDI	275 days	Wed 3/7/18	Thu 12/6/18		Yes					
320	CORING	20 days	Wed 3/7/18	Mon 3/26/18	291	Yes					
321	PASANG PIPA	25 days	Tue 3/27/18	Fri 4/20/18	320	Yes					
322	TEST BOCOR	20 days	Sat 4/21/18	Thu 5/10/18	321	Yes					
323	GROUTING	25 days	Fri 5/11/18	Mon 6/4/18	322	Yes					
324	PASANG HT DINDING	25 days	Fri 7/20/18	Mon 8/13/18	291SS,322,326	Yes					
325	WATER PROOFING	25 days	Tue 6/5/18	Fri 6/29/18	323	Yes					
326	TEST WATER PROOFING	20 days	Sat 6/30/18	Thu 7/19/18	325	Yes					
327	PASANG HT LANTAI	25 days	Wed 10/3/18	Sat 10/27/18	324,326,329	Yes					
328	PASANG RANGKA PLAFOND	25 days	Tue 8/14/18	Fri 9/7/18	324	Yes					
329	TUTUP PLAFOND	25 days	Sat 9/8/18	Tue 10/2/18	328	Yes					

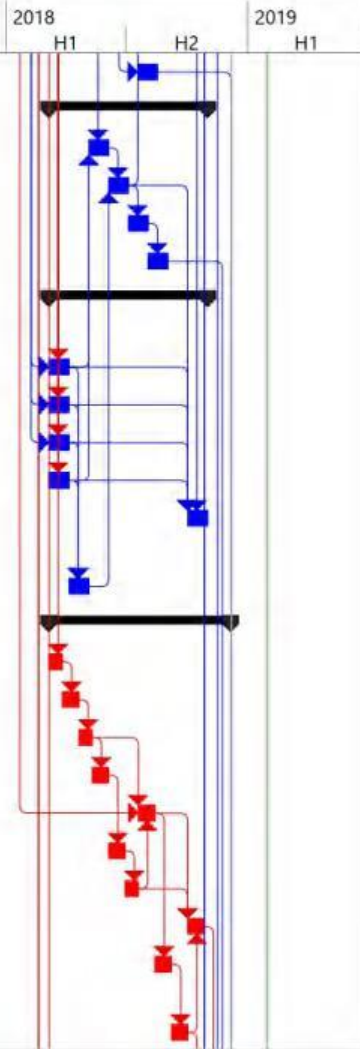

ID	Task Name	Duration	Start	Finish	Predecessors	Critical	2017		2018		2019
							H1	H2	H1	H2	H1
330	CAT PLAFOND	25 days	Wed 10/3/18	Sat 10/27/18	311FF,329	No					
331	PASANG PINTU	20 days	Sun 10/28/18	Fri 11/16/18	292,299,327	Yes					
332	PASANG SANITARY	20 days	Sat 11/17/18	Thu 12/6/18	303,331	Yes					
333	AREA FAÇADE/BALKON	125 days	Mon 2/5/18	Sat 6/9/18		No					
334	PASANG PC PANEL	25 days	Mon 2/5/18	Thu 3/1/18	289	No					
335	PASANG JENDELA ALUMUNIUM	25 days	Fri 3/2/18	Mon 3/26/18	334	No					
336	PASANG RAILING BALKON	30 days	Fri 3/2/18	Sat 3/31/18	334	No					
337	PASANG HT LANTAI	25 days	Wed 5/16/18	Sat 6/9/18	339	No					
338	WATER PROOFING	25 days	Sun 4/1/18	Wed 4/25/18	336	No					
339	TEST WATER PROOFING	20 days	Thu 4/26/18	Tue 5/15/18	338	No					
340	AREA CORIDOR	245.5 days	Mon 2/5/18	Mon 10/8/18		No					
341	Pasang Bata	25 days	Wed 3/7/18	Sat 3/31/18	289FS+30 days	No					
342	Pasang Conduit + Inbodus di Dinding	25 days	Mon 3/19/18	Fri 4/13/18	341SS+50%	No					
343	Pasang Conduit di Plafond	25 days	Mon 3/19/18	Fri 4/13/18	342SS	No					
344	Render/Plaster	25 days	Sun 4/1/18	Wed 4/25/18	342SS+50%	No					
345	Instalasi Kabel	25 days	Sat 3/24/18	Wed 4/18/18	343SS+5 days	No					
346	Instalasi MVAC	25 days	Sat 3/24/18	Wed 4/18/18	343SS+5 days	No					
347	Pipa Fire Fighting	25 days	Mon 2/5/18	Thu 3/1/18	289	No					
348	Test Parsial MEP dalam Plafond	20 days	Sun 5/13/18	Sat 6/2/18	349	No					
349	Rangka Plafond	25 days	Wed 4/18/18	Sun 5/13/18	345,346,347	No					
350	Tutup Plafond	25 days	Tue 6/5/18	Sat 6/30/18	348FS+3 days	No					
351	Pasang HT/Keramik	25 days	Sat 6/30/18	Wed 7/25/18	350	No					

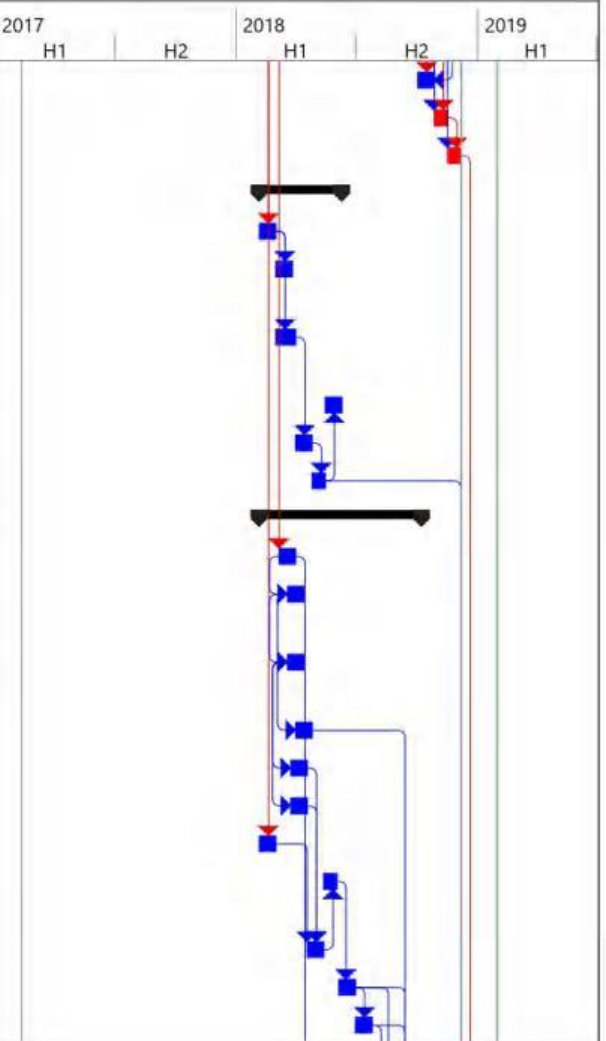

ID	Task Name	Duration	Start	Finish	Predecessors	Critical	2017					2018					2019							
							H1					H2					H1					H2		
352	Railing Tangga	25 days	Sun 4/1/18	Wed 4/25/18	341	No																		
353	ME Fixture di Plafond	25 days	Sun 8/19/18	Thu 9/13/18	350,355	No																		
354	ME Fixture di Dinding	25 days	Sun 8/19/18	Thu 9/13/18	353SS,355	No																		
355	Pintu Besi	25 days	Wed 7/25/18	Sun 8/19/18	351	No																		
356	Pengecatan	25 days	Thu 9/13/18	Mon 10/8/18	344,350,351,352,35	No																		
357	Finish Lantai 6	1 day	Fri 12/7/18	Fri 12/7/18	306,332,339,356	Yes																		

Lampiran 8. Daftar Aktivitas, *Network Planning, Predecessor* Lantai 7

PEMILIK		COMPOSITE SCHEDULE					KONSULTAN MK				
PODO MORO CITY DELI MEGAH		FINISHING-ME TOWER 3L					JAYA CM				
ID	Task Name	Duration	Start	Finish	Predecessors	Critical	2017	2018	2019		
							H1	H2	H1	H2	H1
1	SCHEDULE FINISHING-ME TOWER 3L	346 days	Mon 1/1/18	Wed 12/12/18		Yes					
2	LINCOLN (Lantai LM)	346 days	Mon 1/1/18	Wed 12/12/18		Yes					
3	LANTAI 1	321 days	Mon 1/1/18	Sat 11/17/18		No					
74	LANTAI 2	321 days	Sat 1/6/18	Thu 11/22/18	3SS+5 days	No					
145	LANTAI 3	321 days	Thu 1/11/18	Tue 11/27/18	74SS+5 days	No					
216	LANTAI 5	321 days	Tue 1/16/18	Sun 12/2/18	145SS+5 days	No					
287	LANTAI 6	321 days	Sun 1/21/18	Fri 12/7/18	216SS+5 days	No					
358	LANTAI 7	321 days	Fri 1/26/18	Wed 12/12/18	287SS+5 days	Yes					
359	AREA UNIT	285 days	Fri 1/26/18	Tue 11/6/18		Yes					
360	MARKING	15 days	Fri 1/26/18	Fri 2/9/18		Yes					
361	PEKERJAAN DINDING	270 days	Sat 2/10/18	Tue 11/6/18		Yes					
362	PASANG BATA	30 days	Sat 2/10/18	Sun 3/11/18	360	Yes					
363	PLESTER/RENDER	30 days	Wed 4/11/18	Thu 5/10/18	362,366,367,368	No					
364	CAT DINDING	30 days	Fri 5/11/18	Sat 6/9/18	363	No					
365	MEP DINDING	240 days	Mon 3/12/18	Tue 11/6/18		No					
366	ELEKTRONIK	30 days	Mon 3/12/18	Tue 4/10/18	362	No					
367	ELEKTRIKAL	30 days	Mon 3/12/18	Tue 4/10/18	362	No					
368	MVAC	30 days	Mon 3/12/18	Tue 4/10/18	362	No					
369	FIXTURES MEP DALAM DINDING	30 days	Mon 10/8/18	Tue 11/6/18	366,367,368,373,37	No					
370	TEST MEP	30 days	Wed 4/11/18	Thu 5/10/18	366,367,368	No					
371	PINTU KAYU	60 days	Thu 8/9/18	Sun 10/7/18		No					
372	KUSEN PINTU	30 days	Thu 8/9/18	Fri 9/7/18	363,376	No					
373	DAUN PINTU	30 days	Thu 8/9/18	Fri 9/7/18	364FF,372SS	No					
374	ACESSORIES	30 days	Sat 9/8/18	Sun 10/7/18	373	No					
375	PEKERJAAN LANTAI	44 days	Tue 7/10/18	Wed 8/22/18		No					

ID	Task Name	Duration	Start	Finish	Predecessors	Critical	2017		2018		2019
							H1	H2	H1	H2	H1
376	PASANG MARBEL	30 days	Tue 7/10/18	Wed 8/8/18	380	No					
377	POLES MARBEL	30 days	Tue 7/24/18	Wed 8/22/18	376SS+14 days	No					
378	PEKERJAAN PLAFOND	240 days	Mon 3/12/18	Tue 11/6/18		No					
379	PASANG RANGKA	30 days	Fri 5/11/18	Sat 6/9/18	363,384,387	No					
380	TUTUP PLAFOND	30 days	Sun 6/10/18	Mon 7/9/18	379,389	No					
381	COMPOUND	30 days	Tue 7/10/18	Wed 8/8/18	380	No					
382	CAT PLAFOND	30 days	Thu 8/9/18	Fri 9/7/18	381	No					
383	MEP DALAM PLAFOND	240 days	Mon 3/12/18	Tue 11/6/18		No					
384	ELEKTRIKAL	30 days	Mon 3/12/18	Tue 4/10/18	362,367SS	No					
385	ELEKTRONIK	30 days	Mon 3/12/18	Tue 4/10/18	362,366SS	No					
386	MVAC	30 days	Mon 3/12/18	Tue 4/10/18	362,368SS	No					
387	PLPK	30 days	Mon 3/12/18	Tue 4/10/18	362	No					
388	FIXTURE MEP DALAM PLAFOND	30 days	Mon 10/8/18	Tue 11/6/18	374,380,384,385,38	No					
389	TEST MEP	30 days	Wed 4/11/18	Thu 5/10/18	384,385,386,387	No					
390	AREA KAMAR MANDI	275 days	Mon 3/12/18	Tue 12/11/18		Yes					
391	CORING	20 days	Mon 3/12/18	Sat 3/31/18	362	Yes					
392	PASANG PIPA	25 days	Sun 4/1/18	Wed 4/25/18	391	Yes					
393	TEST BOCOR	20 days	Thu 4/26/18	Tue 5/15/18	392	Yes					
394	GROUTING	25 days	Wed 5/16/18	Sat 6/9/18	393	Yes					
395	PASANG HT DINDING	25 days	Wed 7/25/18	Sat 8/18/18	362SS,393,397	Yes					
396	WATER PROOFING	25 days	Sun 6/10/18	Wed 7/4/18	394	Yes					
397	TEST WATER PROOFING	20 days	Thu 7/5/18	Tue 7/24/18	396	Yes					
398	PASANG HT LANTAI	25 days	Mon 10/8/18	Thu 11/1/18	395,397,400	Yes					
399	PASANG RANGKA PLAFOND	25 days	Sun 8/19/18	Wed 9/12/18	395	Yes					

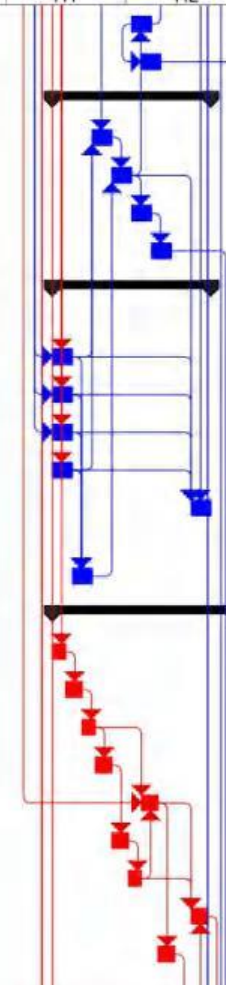

ID	Task Name	Duration	Start	Finish	Predecessors	Critical	Timeline								
							2017	H1	H2	2018	H1	H2	2019	H1	
400	TUTUP PLAFOND	25 days	Thu 9/13/18	Sun 10/7/18	399	Yes									
401	CAT PLAFOND	25 days	Mon 10/8/18	Thu 11/1/18	382FF,400	No									
402	PASANG PINTU	20 days	Fri 11/2/18	Wed 11/21/18	363,370,398	Yes									
403	PASANG SANITARY	20 days	Thu 11/22/18	Tue 12/11/18	374,402	Yes									
404	AREA FAÇADE/BALKON	125 days	Sat 2/10/18	Thu 6/14/18		No									
405	PASANG PC PANEL	25 days	Sat 2/10/18	Tue 3/6/18	360	No									
406	PASANG JENDELA ALUMUNIUM	25 days	Wed 3/7/18	Sat 3/31/18	405	No									
407	PASANG RAILING BALKON	30 days	Wed 3/7/18	Thu 4/5/18	405	No									
408	PASANG HT LANTAI	25 days	Mon 5/21/18	Thu 6/14/18	410	No									
409	WATER PROOFING	25 days	Fri 4/6/18	Mon 4/30/18	407	No									
410	TEST WATER PROOFING	20 days	Tue 5/1/18	Sun 5/20/18	409	No									
411	AREA CORIDOR	245.5 days	Sat 2/10/18	Sat 10/13/18		No									
412	Pasang Bata	25 days	Mon 3/12/18	Thu 4/5/18	360FS+30 days	No									
413	Pasang Conduit + Inbodur di Dinding	25 days	Sat 3/24/18	Wed 4/18/18	412SS+50%	No									
414	Pasang Conduit di Plafond	25 days	Sat 3/24/18	Wed 4/18/18	413SS	No									
415	Render/Plaster	25 days	Fri 4/6/18	Mon 4/30/18	413SS+50%	No									
416	Instalasi Kabel	25 days	Thu 3/29/18	Mon 4/23/18	414SS+5 days	No									
417	Instalasi MVAC	25 days	Thu 3/29/18	Mon 4/23/18	414SS+5 days	No									
418	Pipa Fire Fighting	25 days	Sat 2/10/18	Tue 3/6/18	360	No									
419	Test Parsial MEP dalam Plafond	20 days	Fri 5/18/18	Thu 6/7/18	420	No									
420	Rangka Plafond	25 days	Mon 4/23/18	Fri 5/18/18	416,417,418	No									
421	Tutup Plafond	25 days	Sun 6/10/18	Thu 7/5/18	419FS+3 days	No									

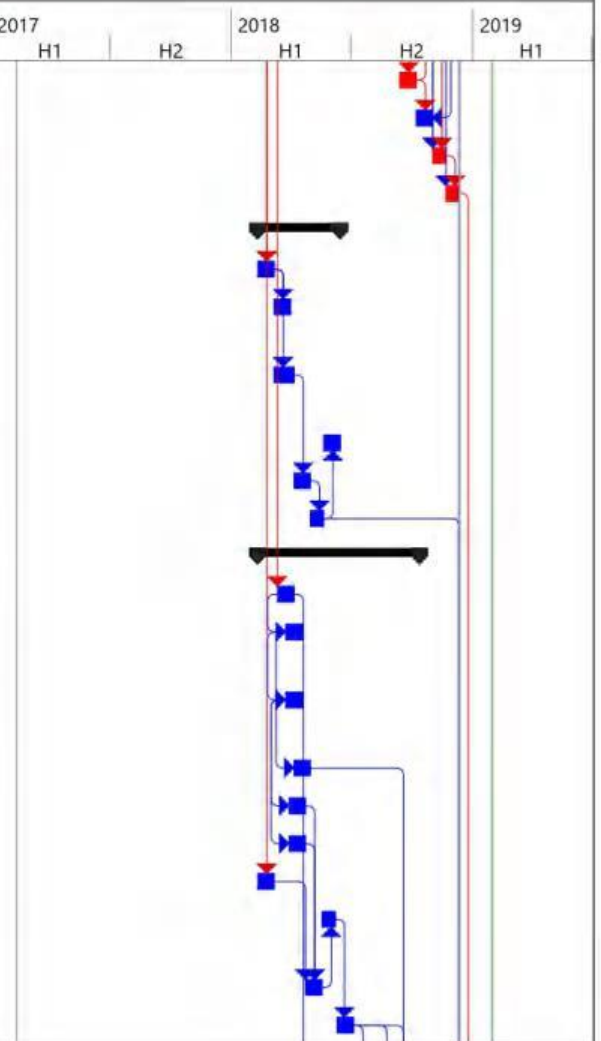

ID	Task Name	Duration	Start	Finish	Predecessors	Critical	2017			2018		2019
							H1	H2	H1	H2	H1	
422	Pasang HT/Keramik	25 days	Thu 7/5/18	Mon 7/30/18	421	No						
423	Railing Tangga	25 days	Fri 4/6/18	Mon 4/30/18	412	No						
424	ME Fixture di Plafond	25 days	Fri 8/24/18	Tue 9/18/18	421,426	No						
425	ME Fixture di Dinding	25 days	Fri 8/24/18	Tue 9/18/18	424SS,426	No						
426	Pintu Besi	25 days	Mon 7/30/18	Fri 8/24/18	422	No						
427	Pengecatan	25 days	Tue 9/18/18	Sat 10/13/18	415,421,422,423,42	No						
428	Finish Lantai 7	1 day	Wed 12/12/18	Wed 12/12/18	377,403,410,427	Yes						

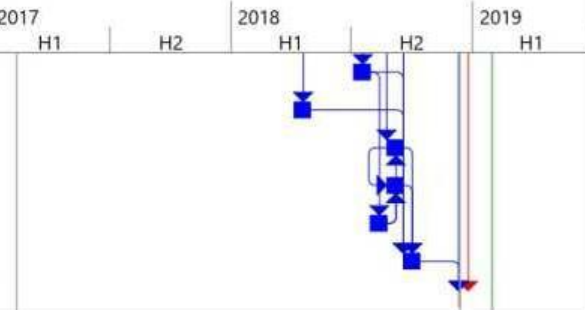

Lampiran 9. Daftar Aktivitas, *Network Planning, Predecessor* Lantai 8

PEMILIK		COMPOSITE SCHEDULE					KONSULTAN MK				
PODO MORO CITY DELI MEGAN		FINISHING-ME TOWER 3L					JAYA CM				
ID	Task Name	Duration	Start	Finish	Predecessors	Critical	2017	2018	2019		
							H1	H2	H1	H2	H1
1	SCHEDULE FINISHING-ME TOWER 3L	351 days	Mon 1/1/18	Mon 12/17/18		Yes					
2	LINCOLN (Lantai LM)	351 days	Mon 1/1/18	Mon 12/17/18		Yes					
3	LANTAI 1	321 days	Mon 1/1/18	Sat 11/17/18		No					
74	LANTAI 2	321 days	Sat 1/6/18	Thu 11/22/18	3SS+5 days	No					
145	LANTAI 3	321 days	Thu 1/11/18	Tue 11/27/18	74SS+5 days	No					
216	LANTAI 5	321 days	Tue 1/16/18	Sun 12/2/18	145SS+5 days	No					
287	LANTAI 6	321 days	Sun 1/21/18	Fri 12/7/18	216SS+5 days	No					
358	LANTAI 7	321 days	Fri 1/26/18	Wed 12/12/18	287SS+5 days	No					
429	LANTAI 8	321 days	Wed 1/31/18	Mon 12/17/18	358SS+5 days	Yes					
430	AREA UNIT	285 days	Wed 1/31/18	Sun 11/11/18		Yes					
431	MARKING	15 days	Wed 1/31/18	Wed 2/14/18		Yes					
432	PEKERJAAN DINDING	270 days	Thu 2/15/18	Sun 11/11/18		Yes					
433	PASANG BATA	30 days	Thu 2/15/18	Fri 3/16/18	431	Yes					
434	PLESTER/RENDER	30 days	Mon 4/16/18	Tue 5/15/18	433,437,438,439	No					
435	CAT DINDING	30 days	Wed 5/16/18	Thu 6/14/18	434	No					
436	MEP DINDING	240 days	Sat 3/17/18	Sun 11/11/18		No					
437	ELEKTRONIK	30 days	Sat 3/17/18	Sun 4/15/18	433	No					
438	ELEKTRIKAL	30 days	Sat 3/17/18	Sun 4/15/18	433	No					
439	MVAC	30 days	Sat 3/17/18	Sun 4/15/18	433	No					
440	FIXTURES MEP DALAM DINDING	30 days	Sat 10/13/18	Sun 11/11/18	437,438,439,444,44	No					
441	TEST MEP	30 days	Mon 4/16/18	Tue 5/15/18	437,438,439	No					
442	PINTU KAYU	60 days	Tue 8/14/18	Fri 10/12/18		No					
443	KUSEN PINTU	30 days	Tue 8/14/18	Wed 9/12/18	434,447	No					
444	DAUN PINTU	30 days	Tue 8/14/18	Wed 9/12/18	435FF,443SS	No					
445	ACESSORIES	30 days	Thu 9/13/18	Fri 10/12/18	444	No					

ID	Task Name	Duration	Start	Finish	Predecessors	Critical	2017		2018		2019
							H1	H2	H1	H2	H1
446	PEKERJAAN LANTAI	44 days	Sun 7/15/18	Mon 8/27/18		No					
447	PASANG MARBEL	30 days	Sun 7/15/18	Mon 8/13/18	451	No					
448	POLES MARBEL	30 days	Sun 7/29/18	Mon 8/27/18	447SS+14 days	No					
449	PEKERJAAN PLAFOND	240 days	Sat 3/17/18	Sun 11/11/18		No					
450	PASANG RANGKA	30 days	Wed 5/16/18	Thu 6/14/18	434,455,458	No					
451	TUTUP PLAFOND	30 days	Fri 6/15/18	Sat 7/14/18	450,460	No					
452	COMPOUND	30 days	Sun 7/15/18	Mon 8/13/18	451	No					
453	CAT PLAFOND	30 days	Tue 8/14/18	Wed 9/12/18	452	No					
454	MEP DALAM PLAFOND	240 days	Sat 3/17/18	Sun 11/11/18		No					
455	ELEKTRIKAL	30 days	Sat 3/17/18	Sun 4/15/18	433,438SS	No					
456	ELEKTRONIK	30 days	Sat 3/17/18	Sun 4/15/18	433,437SS	No					
457	MVAC	30 days	Sat 3/17/18	Sun 4/15/18	433,439SS	No					
458	PLPK	30 days	Sat 3/17/18	Sun 4/15/18	433	No					
459	FIXTURE MEP DALAM PLAFOND	30 days	Sat 10/13/18	Sun 11/11/18	445,451,455,456,45	No					
460	TEST MEP	30 days	Mon 4/16/18	Tue 5/15/18	455,456,457,458	No					
461	AREA KAMAR MANDI	275 days	Sat 3/17/18	Sun 12/16/18		Yes					
462	CORING	20 days	Sat 3/17/18	Thu 4/5/18	433	Yes					
463	PASANG PIPA	25 days	Fri 4/6/18	Mon 4/30/18	462	Yes					
464	TEST BOCOR	20 days	Tue 5/1/18	Sun 5/20/18	463	Yes					
465	GROUTING	25 days	Mon 5/21/18	Thu 6/14/18	464	Yes					
466	PASANG HT DINDING	25 days	Mon 7/30/18	Thu 8/23/18	433SS,464,468	Yes					
467	WATER PROOFING	25 days	Fri 6/15/18	Mon 7/9/18	465	Yes					
468	TEST WATER PROOFING	20 days	Tue 7/10/18	Sun 7/29/18	467	Yes					
469	PASANG HT LANTAI	25 days	Sat 10/13/18	Tue 11/6/18	466,468,471	Yes					

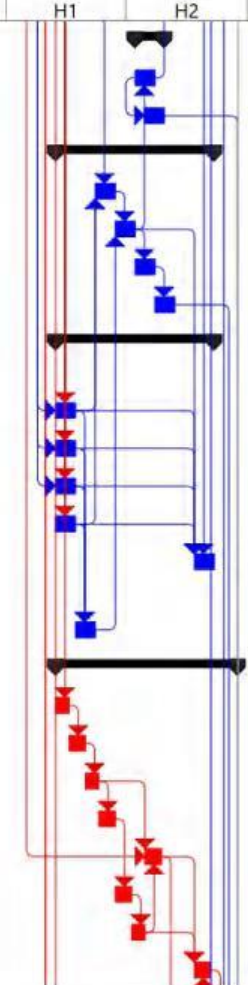

ID	Task Name	Duration	Start	Finish	Predecessors	Critical	2017	2018	2019
							H1	H2	H1
470	PASANG RANGKA PLAFOND	25 days	Fri 8/24/18	Mon 9/17/18	466	Yes			
471	TUTUP PLAFOND	25 days	Tue 9/18/18	Fri 10/12/18	470	Yes			
472	CAT PLAFOND	25 days	Sat 10/13/18	Tue 11/6/18	453FF,471	No			
473	PASANG PINTU	20 days	Wed 11/7/18	Mon 11/26/18	434,441,469	Yes			
474	PASANG SANITARY	20 days	Tue 11/27/18	Sun 12/16/18	445,473	Yes			
475	AREA FAÇADE/BALKON	125 days	Thu 2/15/18	Tue 6/19/18		No			
476	PASANG PC PANEL	25 days	Thu 2/15/18	Sun 3/11/18	431	No			
477	PASANG JENDELA ALUMINIUM	25 days	Mon 3/12/18	Thu 4/5/18	476	No			
478	PASANG RAILING BALKON	30 days	Mon 3/12/18	Tue 4/10/18	476	No			
479	PASANG HT LANTAI	25 days	Sat 5/26/18	Tue 6/19/18	481	No			
480	WATER PROOFING	25 days	Wed 4/11/18	Sat 5/5/18	478	No			
481	TEST WATER PROOFING	20 days	Sun 5/6/18	Fri 5/25/18	480	No			
482	AREA CORIDOR	245.5 days	Thu 2/15/18	Thu 10/18/18		No			
483	Pasang Bata	25 days	Sat 3/17/18	Tue 4/10/18	431FS+30 days	No			
484	Pasang Conduit + Inbodur di Dinding	25 days	Thu 3/29/18	Mon 4/23/18	483SS+50%	No			
485	Pasang Conduit di Plafond	25 days	Thu 3/29/18	Mon 4/23/18	484SS	No			
486	Render/Plaster	25 days	Wed 4/11/18	Sat 5/5/18	484SS+50%	No			
487	Instalasi Kabel	25 days	Tue 4/3/18	Sat 4/28/18	485SS+5 days	No			
488	Instalasi MVAC	25 days	Tue 4/3/18	Sat 4/28/18	485SS+5 days	No			
489	Pipa Fire Fighting	25 days	Thu 2/15/18	Sun 3/11/18	431	No			
490	Test Parsial MEP dalam Plafond	20 days	Wed 5/23/18	Tue 6/12/18	491	No			
491	Rangka Plafond	25 days	Sat 4/28/18	Wed 5/23/18	487,488,489	No			

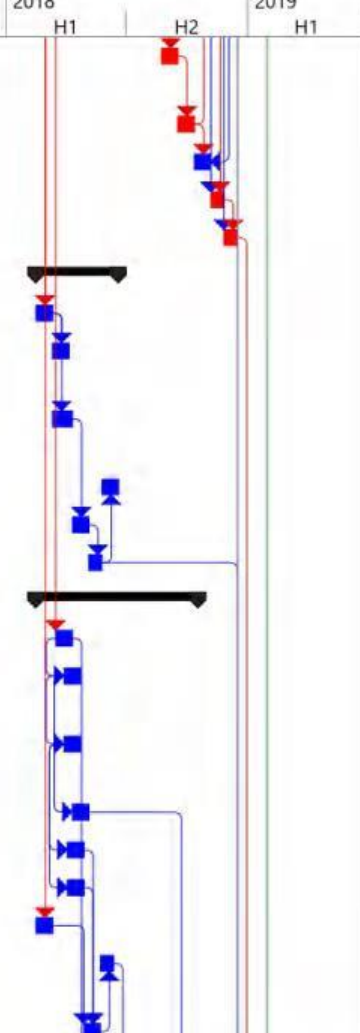

ID	Task Name	Duration	Start	Finish	Predecessors	Critical	Gantt Chart									
							2017	H1	H2	2018	H1	H2	2019	H1		
492	Tutup Plafond	25 days	Fri 6/15/18	Tue 7/10/18	490FS+3 days	No										
493	Pasang HT/Keramik	25 days	Tue 7/10/18	Sat 8/4/18	492	No										
494	Railing Tangga	25 days	Wed 4/11/18	Sat 5/5/18	483	No										
495	ME Fixture di Plafond	25 days	Wed 8/29/18	Sun 9/23/18	492,497	No										
496	ME Fixture di Dinding	25 days	Wed 8/29/18	Sun 9/23/18	495SS,497	No										
497	Pintu Besi	25 days	Sat 8/4/18	Wed 8/29/18	493	No										
498	Pengecatan	25 days	Sun 9/23/18	Thu 10/18/18	486,492,493,494,49	No										
499	Finish Lantai 8	1 day	Mon 12/17/18	Mon 12/17/18	448,474,481,498	Yes										

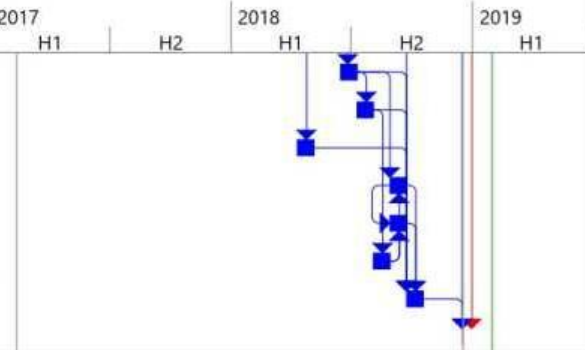

Lampiran 10. Daftar Aktivitas, *Network Planning, Predecessor* Lantai 9

PEMILIK		COMPOSITE SCHEDULE					KONSULTAN MK				
PODO MORO CITY		FINISHING-ME TOWER 3L					JAYA CM				
ID	Task Name	Duration	Start	Finish	Predecessors	Critical	2017	2018	2019		
							H1	H2	H1	H2	H1
1	SCHEDULE FINISHING-ME TOWER 3L	356 days	Mon 1/1/18	Sat 12/22/18		Yes					
2	LINCOLN (Lantai LM)	356 days	Mon 1/1/18	Sat 12/22/18		Yes					
3	LANTAI 1	321 days	Mon 1/1/18	Sat 11/17/18		No					
74	LANTAI 2	321 days	Sat 1/6/18	Thu 11/22/18	3SS+5 days	No					
145	LANTAI 3	321 days	Thu 1/11/18	Tue 11/27/18	74SS+5 days	No					
216	LANTAI 5	321 days	Tue 1/16/18	Sun 12/2/18	145SS+5 days	No					
287	LANTAI 6	321 days	Sun 1/21/18	Fri 12/7/18	216SS+5 days	No					
358	LANTAI 7	321 days	Fri 1/26/18	Wed 12/12/18	287SS+5 days	No					
429	LANTAI 8	321 days	Wed 1/31/18	Mon 12/17/18	358SS+5 days	No					
500	LANTAI 9	321 days	Mon 2/5/18	Sat 12/22/18	429SS+5 days	Yes					
501	AREA UNIT	285 days	Mon 2/5/18	Fri 11/16/18		Yes					
502	MARKING	15 days	Mon 2/5/18	Mon 2/19/18		Yes					
503	PEKERJAAN DINDING	270 days	Tue 2/20/18	Fri 11/16/18		Yes					
504	PASANG BATA	30 days	Tue 2/20/18	Wed 3/21/18	502	Yes					
505	PLESTER/RENDER	30 days	Sat 4/21/18	Sun 5/20/18	504,508,509,510	No					
506	CAT DINDING	30 days	Mon 5/21/18	Tue 6/19/18	505	No					
507	MEP DINDING	240 days	Thu 3/22/18	Fri 11/16/18		No					
508	ELEKTRONIK	30 days	Thu 3/22/18	Fri 4/20/18	504	No					
509	ELEKTRIKAL	30 days	Thu 3/22/18	Fri 4/20/18	504	No					
510	MVAC	30 days	Thu 3/22/18	Fri 4/20/18	504	No					
511	FIXTURES MEP DALAM DINDING	30 days	Thu 10/18/18	Fri 11/16/18	508,509,510,515,51	No					
512	TEST MEP	30 days	Sat 4/21/18	Sun 5/20/18	508,509,510	No					
513	PINTU KAYU	60 days	Sun 8/19/18	Wed 10/17/18		No					
514	KUSEN PINTU	30 days	Sun 8/19/18	Mon 9/17/18	505,518	No					
515	DAUN PINTU	30 days	Sun 8/19/18	Mon 9/17/18	506FF,514SS	No					

ID	Task Name	Duration	Start	Finish	Predecessors	Critical	2017		2018		2019
							H1	H2	H1	H2	H1
516	ACESSORIES	30 days	Tue 9/18/18	Wed 10/17/18	515	No					
517	PEKERJAAN LANTAI	44 days	Fri 7/20/18	Sat 9/1/18		No					
518	PASANG MARBEL	30 days	Fri 7/20/18	Sat 8/18/18	522	No					
519	POLES MARBEL	30 days	Fri 8/3/18	Sat 9/1/18	518SS+14 days	No					
520	PEKERJAAN PLAFOND	240 days	Thu 3/22/18	Fri 11/16/18		No					
521	PASANG RANGKA	30 days	Mon 5/21/18	Tue 6/19/18	505,526,529	No					
522	TUTUP PLAFOND	30 days	Wed 6/20/18	Thu 7/19/18	521,531	No					
523	COMPOUND	30 days	Fri 7/20/18	Sat 8/18/18	522	No					
524	CAT PLAFOND	30 days	Sun 8/19/18	Mon 9/17/18	523	No					
525	MEP DALAM PLAFOND	240 days	Thu 3/22/18	Fri 11/16/18		No					
526	ELEKTRIKAL	30 days	Thu 3/22/18	Fri 4/20/18	504,509SS	No					
527	ELEKTRONIK	30 days	Thu 3/22/18	Fri 4/20/18	504,508SS	No					
528	MVAC	30 days	Thu 3/22/18	Fri 4/20/18	504,510SS	No					
529	PLPK	30 days	Thu 3/22/18	Fri 4/20/18	504	No					
530	FIXTURE MEP DALAM PLAFOND	30 days	Thu 10/18/18	Fri 11/16/18	516,522,526,527,52	No					
531	TEST MEP	30 days	Sat 4/21/18	Sun 5/20/18	526,527,528,529	No					
532	AREA KAMAR MANDI	275 days	Thu 3/22/18	Fri 12/21/18		Yes					
533	CORING	20 days	Thu 3/22/18	Tue 4/10/18	504	Yes					
534	PASANG PIPA	25 days	Wed 4/11/18	Sat 5/5/18	533	Yes					
535	TEST BOCOR	20 days	Sun 5/6/18	Fri 5/25/18	534	Yes					
536	GROUTING	25 days	Sat 5/26/18	Tue 6/19/18	535	Yes					
537	PASANG HT DINDING	25 days	Sat 8/4/18	Tue 8/28/18	504SS,535,539	Yes					
538	WATER PROOFING	25 days	Wed 6/20/18	Sat 7/14/18	536	Yes					
539	TEST WATER PROOFING	20 days	Sun 7/15/18	Fri 8/3/18	538	Yes					
540	PASANG HT LANTAI	25 days	Thu 10/18/18	Sun 11/11/18	537,539,542	Yes					

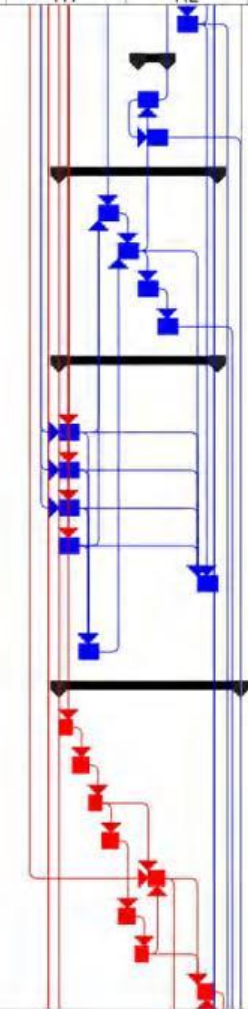

ID	Task Name	Duration	Start	Finish	Predecessors	Critical	2017	2018	2019
							H1	H2	H1
541	PASANG RANGKA PLAFOND	25 days	Wed 8/29/18	Sat 9/22/18	537	Yes			
542	TUTUP PLAFOND	25 days	Sun 9/23/18	Wed 10/17/18	541	Yes			
543	CAT PLAFOND	25 days	Thu 10/18/18	Sun 11/11/18	524FF,542	No			
544	PASANG PINTU	20 days	Mon 11/12/18	Sat 12/1/18	505,512,540	Yes			
545	PASANG SANITARY	20 days	Sun 12/2/18	Fri 12/21/18	516,544	Yes			
546	AREA FAÇADE/BALKON	125 days	Tue 2/20/18	Sun 6/24/18		No			
547	PASANG PC PANEL	25 days	Tue 2/20/18	Fri 3/16/18	502	No			
548	PASANG JENDELA ALUMUNIUM	25 days	Sat 3/17/18	Tue 4/10/18	547	No			
549	PASANG RAILING BALKON	30 days	Sat 3/17/18	Sun 4/15/18	547	No			
550	PASANG HT LANTAI	25 days	Thu 5/31/18	Sun 6/24/18	552	No			
551	WATER PROOFING	25 days	Mon 4/16/18	Thu 5/10/18	549	No			
552	TEST WATER PROOFING	20 days	Fri 5/11/18	Wed 5/30/18	551	No			
553	AREA CORIDOR	245.5 days	Tue 2/20/18	Tue 10/23/18		No			
554	Pasang Bata	25 days	Thu 3/22/18	Sun 4/15/18	502FS+30 days	No			
555	Pasang Conduit + Inbodus di Dinding	25 days	Tue 4/3/18	Sat 4/28/18	554SS+50%	No			
556	Pasang Conduit di Plafond	25 days	Tue 4/3/18	Sat 4/28/18	555SS	No			
557	Render/Plaster	25 days	Mon 4/16/18	Thu 5/10/18	555SS+50%	No			
558	Instalasi Kabel	25 days	Sun 4/8/18	Thu 5/3/18	556SS+5 days	No			
559	Instalasi MVAC	25 days	Sun 4/8/18	Thu 5/3/18	556SS+5 days	No			
560	Pipa Fire Fighting	25 days	Tue 2/20/18	Fri 3/16/18	502	No			
561	Test Parsial MEP dalam Plafond	20 days	Mon 5/28/18	Sun 6/17/18	562	No			
562	Rangka Plafond	25 days	Thu 5/3/18	Mon 5/28/18	558,559,560	No			

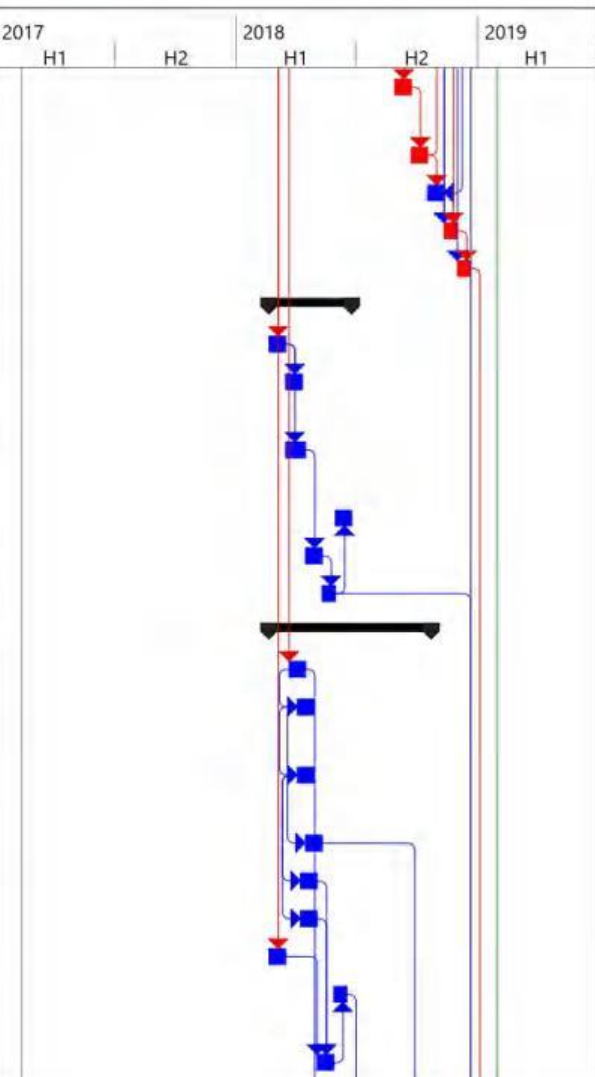

ID	Task Name	Duration	Start	Finish	Predecessors	Critical	Gantt Chart									
							2017	H1	H2	2018	H1	H2	2019	H1		
563	Tutup Plafond	25 days	Wed 6/20/18	Sun 7/15/18	561FS+3 days	No										
564	Pasang HT/Keramik	25 days	Sun 7/15/18	Thu 8/9/18	563	No										
565	Railing Tangga	25 days	Mon 4/16/18	Thu 5/10/18	554	No										
566	ME Fixture di Plafond	25 days	Mon 9/3/18	Fri 9/28/18	563,568	No										
567	ME Fixture di Dinding	25 days	Mon 9/3/18	Fri 9/28/18	566SS,568	No										
568	Pintu Besi	25 days	Thu 8/9/18	Mon 9/3/18	564	No										
569	Pengecatan	25 days	Fri 9/28/18	Tue 10/23/18	557,563,564,565,56	No										
570	Finish Lantai 9	1 day	Sat 12/22/18	Sat 12/22/18	519,545,552,569	Yes										

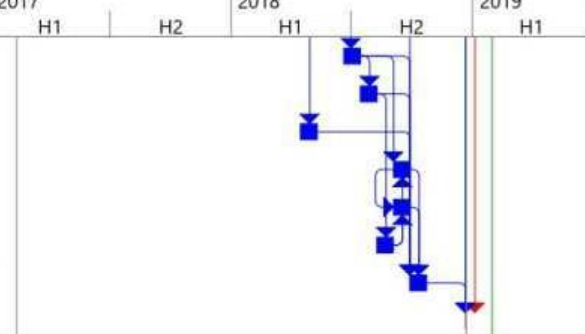

Lampiran 11. Daftar Aktivitas, *Network Planning, Predecessor* Lantai 10

PEMILIK		COMPOSITE SCHEDULE					KONSULTAN MK				
PODO MORO CITY DELI MEGAN		FINISHING-ME TOWER 3L					JAYA CM				
ID	Task Name	Duration	Start	Finish	Predecessors	Critical	2017		2018		2019
							H1	H2	H1	H2	H1
1	SCHEDULE FINISHING-ME TOWER 3L	361 days	Mon 1/1/18	Thu 12/27/18		Yes					
2	LINCOLN (Lantai LM)	361 days	Mon 1/1/18	Thu 12/27/18		Yes					
3	LANTAI 1	321 days	Mon 1/1/18	Sat 11/17/18		No					
74	LANTAI 2	321 days	Sat 1/6/18	Thu 11/22/18	35S+5 days	No					
145	LANTAI 3	321 days	Thu 1/11/18	Tue 11/27/18	74SS+5 days	No					
216	LANTAI 5	321 days	Tue 1/16/18	Sun 12/2/18	145SS+5 days	No					
287	LANTAI 6	321 days	Sun 1/21/18	Fri 12/7/18	216SS+5 days	No					
358	LANTAI 7	321 days	Fri 1/26/18	Wed 12/12/18	287SS+5 days	No					
429	LANTAI 8	321 days	Wed 1/31/18	Mon 12/17/18	358SS+5 days	No					
500	LANTAI 9	321 days	Mon 2/5/18	Sat 12/22/18	429SS+5 days	No					
571	LANTAI 10	321 days	Sat 2/10/18	Thu 12/27/18	500SS+5 days	Yes					
572	AREA UNIT	285 days	Sat 2/10/18	Wed 11/21/18		Yes					
573	MARKING	15 days	Sat 2/10/18	Sat 2/24/18		Yes					
574	PEKERJAAN DINDING	270 days	Sun 2/25/18	Wed 11/21/18		Yes					
575	PASANG BATA	30 days	Sun 2/25/18	Mon 3/26/18	573	Yes					
576	PLESTER/RENDER	30 days	Thu 4/26/18	Fri 5/25/18	575,579,580,581	No					
577	CAT DINDING	30 days	Sat 5/26/18	Sun 6/24/18	576	No					
578	MEP DINDING	240 days	Tue 3/27/18	Wed 11/21/18		No					
579	ELEKTRONIK	30 days	Tue 3/27/18	Wed 4/25/18	575	No					
580	ELEKTRIKAL	30 days	Tue 3/27/18	Wed 4/25/18	575	No					
581	MVAC	30 days	Tue 3/27/18	Wed 4/25/18	575	No					
582	FIXTURES MEP DALAM DINDING	30 days	Tue 10/23/18	Wed 11/21/18	579,580,581,586,58	No					
583	TEST MEP	30 days	Thu 4/26/18	Fri 5/25/18	579,580,581	No					
584	PINTU KAYU	60 days	Fri 8/24/18	Mon 10/22/18		No					
585	KUSEN PINTU	30 days	Fri 8/24/18	Sat 9/22/18	576,589	No					

ID	Task Name	Duration	Start	Finish	Predecessors	Critical	2017		2018		2019
							H1	H2	H1	H2	H1
586	DAUN PINTU	30 days	Fri 8/24/18	Sat 9/22/18	577FF,585SS	No					
587	ACESSORIES	30 days	Sun 9/23/18	Mon 10/22/18	586	No					
588	PEKERJAAN LANTAI	44 days	Wed 7/25/18	Thu 9/6/18		No					
589	PASANG MARBEL	30 days	Wed 7/25/18	Thu 8/23/18	593	No					
590	POLES MARBEL	30 days	Wed 8/8/18	Thu 9/6/18	589SS+14 days	No					
591	PEKERJAAN PLAFOND	240 days	Tue 3/27/18	Wed 11/21/18		No					
592	PASANG RANGKA	30 days	Sat 5/26/18	Sun 6/24/18	576,597,600	No					
593	TUTUP PLAFOND	30 days	Mon 6/25/18	Tue 7/24/18	592,602	No					
594	COMPOUND	30 days	Wed 7/25/18	Thu 8/23/18	593	No					
595	CAT PLAFOND	30 days	Fri 8/24/18	Sat 9/22/18	594	No					
596	MEP DALAM PLAFOND	240 days	Tue 3/27/18	Wed 11/21/18		No					
597	ELEKTRIKAL	30 days	Tue 3/27/18	Wed 4/25/18	575,580SS	No					
598	ELEKTRONIK	30 days	Tue 3/27/18	Wed 4/25/18	575,579SS	No					
599	MVAC	30 days	Tue 3/27/18	Wed 4/25/18	575,581SS	No					
600	PLPK	30 days	Tue 3/27/18	Wed 4/25/18	575	No					
601	FIXTURE MEP DALAM PLAFOND	30 days	Tue 10/23/18	Wed 11/21/18	587,593,597,598,599	No					
602	TEST MEP	30 days	Thu 4/26/18	Fri 5/25/18	597,598,599,600	No					
603	AREA KAMAR MANDI	275 days	Tue 3/27/18	Wed 12/26/18		Yes					
604	CORING	20 days	Tue 3/27/18	Sun 4/15/18	575	Yes					
605	PASANG PIPA	25 days	Mon 4/16/18	Thu 5/10/18	604	Yes					
606	TEST BOCOR	20 days	Fri 5/11/18	Wed 5/30/18	605	Yes					
607	GROUTING	25 days	Thu 5/31/18	Sun 6/24/18	606	Yes					
608	PASANG HT DINDING	25 days	Thu 8/9/18	Sun 9/2/18	575SS,606,610	Yes					
609	WATER PROOFING	25 days	Mon 6/25/18	Thu 7/19/18	607	Yes					
610	TEST WATER PROOFING	20 days	Fri 7/20/18	Wed 8/8/18	609	Yes					

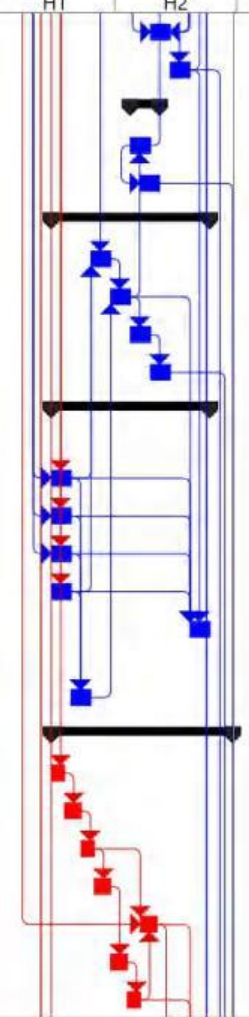

ID	Task Name	Duration	Start	Finish	Predecessors	Critical	2017		2018		2019
							H1	H2	H1	H2	H1
611	PASANG HT LANTAI	25 days	Tue 10/23/18	Fri 11/16/18	608,610,613	Yes					
612	PASANG RANGKA PLAFOND	25 days	Mon 9/3/18	Thu 9/27/18	608	Yes					
613	TUTUP PLAFOND	25 days	Fri 9/28/18	Mon 10/22/18	612	Yes					
614	CAT PLAFOND	25 days	Tue 10/23/18	Fri 11/16/18	595FF,613	No					
615	PASANG PINTU	20 days	Sat 11/17/18	Thu 12/6/18	576,583,611	Yes					
616	PASANG SANITARY	20 days	Fri 12/7/18	Wed 12/26/18	587,615	Yes					
617	AREA FAÇADE/BALKON	125 days	Sun 2/25/18	Fri 6/29/18		No					
618	PASANG PC PANEL	25 days	Sun 2/25/18	Wed 3/21/18	573	No					
619	PASANG JENDELA ALUMUNIUM	25 days	Thu 3/22/18	Sun 4/15/18	618	No					
620	PASANG RAILING BALKON	30 days	Thu 3/22/18	Fri 4/20/18	618	No					
621	PASANG HT LANTAI	25 days	Tue 6/5/18	Fri 6/29/18	623	No					
622	WATER PROOFING	25 days	Sat 4/21/18	Tue 5/15/18	620	No					
623	TEST WATER PROOFING	20 days	Wed 5/16/18	Mon 6/4/18	622	No					
624	AREA CORIDOR	245.5 days	Sun 2/25/18	Sun 10/28/18		No					
625	Pasang Bata	25 days	Tue 3/27/18	Fri 4/20/18	573FS+30 days	No					
626	Pasang Conduit + Inbodur di Dinding	25 days	Sun 4/8/18	Thu 5/3/18	625SS+50%	No					
627	Pasang Conduit di Plafond	25 days	Sun 4/8/18	Thu 5/3/18	626SS	No					
628	Render/Plaster	25 days	Sat 4/21/18	Tue 5/15/18	626SS+50%	No					
629	Instalasi Kabel	25 days	Fri 4/13/18	Tue 5/8/18	627SS+5 days	No					
630	Instalasi MVAC	25 days	Fri 4/13/18	Tue 5/8/18	627SS+5 days	No					
631	Pipa Fire Fighting	25 days	Sun 2/25/18	Wed 3/21/18	573	No					
632	Test Parsial MEP dalam Plafond	20 days	Sat 6/2/18	Fri 6/22/18	633	No					

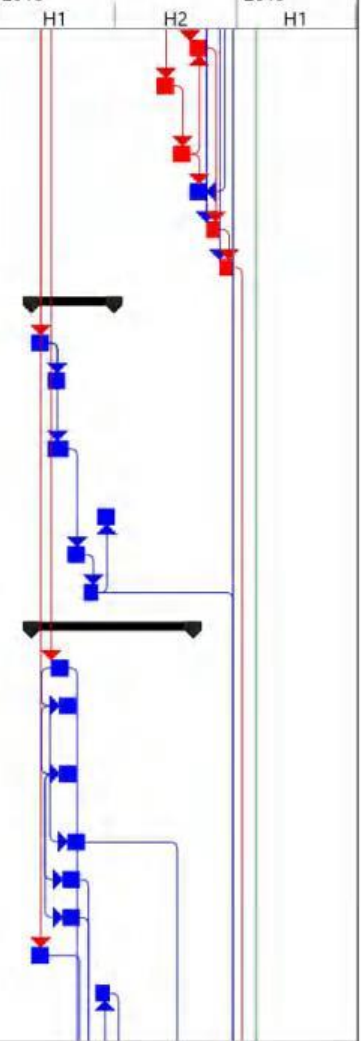

ID	Task Name	Duration	Start	Finish	Predecessors	Critical	Gantt Chart										
							2017	H1	H2	2018	H1	H2	2019	H1			
633	Rangka Plafond	25 days	Tue 5/8/18	Sat 6/2/18	629,630,631	No											
634	Tutup Plafond	25 days	Mon 6/25/18	Fri 7/20/18	632FS+3 days	No											
635	Pasang HT/Keramik	25 days	Fri 7/20/18	Tue 8/14/18	634	No											
636	Railing Tangga	25 days	Sat 4/21/18	Tue 5/15/18	625	No											
637	ME Fixture di Plafond	25 days	Sat 9/8/18	Wed 10/3/18	634,639	No											
638	ME Fixture di Dinding	25 days	Sat 9/8/18	Wed 10/3/18	637SS,639	No											
639	Pintu Besi	25 days	Tue 8/14/18	Sat 9/8/18	635	No											
640	Pengecatan	25 days	Wed 10/3/18	Sun 10/28/18	628,634,635,636,63	No											
641	Finish Lantai 10	1 day	Thu 12/27/18	Thu 12/27/18	590,616,623,640	Yes											

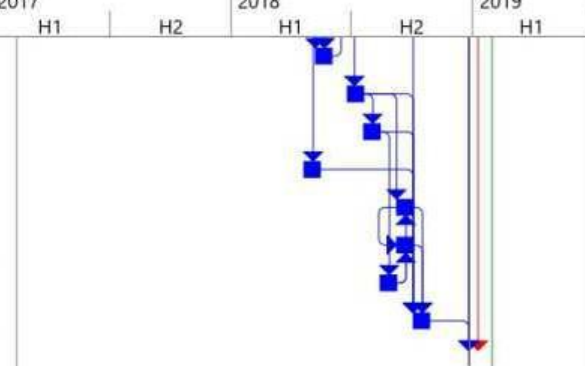

Lampiran 12. Daftar Aktivitas, *Network Planning, Predecessor* Lantai 11

PEMILIK		COMPOSITE SCHEDULE					KONSULTAN MK					
PODO MORO CITY		FINISHING-ME TOWER 3L					JAYA CM					
ID	Task Name	Duration	Start	Finish	Predecessors	Critical	2017	2018	2019			
							H1	H2	H1	H2	H1	H2
1	SCHEDULE FINISHING-ME TOWER 3L	366 days	Mon 1/1/18	Tue 1/1/19		Yes						
2	LINCOLN (Lantai LM)	366 days	Mon 1/1/18	Tue 1/1/19		Yes						
3	LANTAI 1	321 days	Mon 1/1/18	Sat 11/17/18		No						
74	LANTAI 2	321 days	Sat 1/6/18	Thu 11/22/18	355+5 days	No						
145	LANTAI 3	321 days	Thu 1/11/18	Tue 11/27/18	7455+5 days	No						
216	LANTAI 5	321 days	Tue 1/16/18	Sun 12/2/18	14555+5 days	No						
287	LANTAI 6	321 days	Sun 1/21/18	Fri 12/7/18	21655+5 days	No						
358	LANTAI 7	321 days	Fri 1/26/18	Wed 12/12/18	28755+5 days	No						
429	LANTAI 8	321 days	Wed 1/31/18	Mon 12/17/18	35855+5 days	No						
500	LANTAI 9	321 days	Mon 2/5/18	Sat 12/22/18	42955+5 days	No						
571	LANTAI 10	321 days	Sat 2/10/18	Thu 12/27/18	50055+5 days	No						
642	LANTAI 11	321 days	Thu 2/15/18	Tue 1/1/19	57155+5 days	Yes						
643	AREA UNIT	285 days	Thu 2/15/18	Mon 11/26/18		Yes						
644	MARKING	15 days	Thu 2/15/18	Thu 3/1/18		Yes						
645	PEKERJAAN DINDING	270 days	Fri 3/2/18	Mon 11/26/18		Yes						
646	PASANG BATA	30 days	Fri 3/2/18	Sat 3/31/18	644	Yes						
647	PLESTER/RENDER	30 days	Tue 5/1/18	Wed 5/30/18	646,650,651,652	No						
648	CAT DINDING	30 days	Thu 5/31/18	Fri 6/29/18	647	No						
649	MEP DINDING	240 days	Sun 4/1/18	Mon 11/26/18		No						
650	ELEKTRONIK	30 days	Sun 4/1/18	Mon 4/30/18	646	No						
651	ELEKTRIKAL	30 days	Sun 4/1/18	Mon 4/30/18	646	No						
652	MVAC	30 days	Sun 4/1/18	Mon 4/30/18	646	No						
653	FIXTURES MEP DALAM DINDING	30 days	Sun 10/28/18	Mon 11/26/18	650,651,652,657,65	No						
654	TEST MEP	30 days	Tue 5/1/18	Wed 5/30/18	650,651,652	No						
655	PINTU KAYU	60 days	Wed 8/29/18	Sat 10/27/18		No						

ID	Task Name	Duration	Start	Finish	Predecessors	Critical	2017		2018		2019	
							H1	H2	H1	H2	H1	H2
656	KUSEN PINTU	30 days	Wed 8/29/18	Thu 9/27/18	647,660	No						
657	DAUN PINTU	30 days	Wed 8/29/18	Thu 9/27/18	648FF,656SS	No						
658	ACESSORIES	30 days	Fri 9/28/18	Sat 10/27/18	657	No						
659	PEKERJAAN LANTAI	44 days	Mon 7/30/18	Tue 9/11/18		No						
660	PASANG MARBEL	30 days	Mon 7/30/18	Tue 8/28/18	664	No						
661	POLES MARBEL	30 days	Mon 8/13/18	Tue 9/11/18	660SS+14 days	No						
662	PEKERJAAN PLAFOND	240 days	Sun 4/1/18	Mon 11/26/18		No						
663	PASANG RANGKA	30 days	Thu 5/31/18	Fri 6/29/18	647,668,671	No						
664	TUTUP PLAFOND	30 days	Sat 6/30/18	Sun 7/29/18	663,673	No						
665	COMPOUND	30 days	Mon 7/30/18	Tue 8/28/18	664	No						
666	CAT PLAFOND	30 days	Wed 8/29/18	Thu 9/27/18	665	No						
667	MEP DALAM PLAFOND	240 days	Sun 4/1/18	Mon 11/26/18		No						
668	ELEKTRIKAL	30 days	Sun 4/1/18	Mon 4/30/18	646,651SS	No						
669	ELEKTRONIK	30 days	Sun 4/1/18	Mon 4/30/18	646,650SS	No						
670	MVAC	30 days	Sun 4/1/18	Mon 4/30/18	646,652SS	No						
671	PLPK	30 days	Sun 4/1/18	Mon 4/30/18	646	No						
672	FIXTURE MEP DALAM PLAFOND	30 days	Sun 10/28/18	Mon 11/26/18	658,664,668,669,670	No						
673	TEST MEP	30 days	Tue 5/1/18	Wed 5/30/18	668,669,670,671	No						
674	AREA KAMAR MANDI	275 days	Sun 4/1/18	Mon 12/31/18		Yes						
675	CORING	20 days	Sun 4/1/18	Fri 4/20/18	646	Yes						
676	PASANG PIPA	25 days	Sat 4/21/18	Tue 5/15/18	675	Yes						
677	TEST BOCOR	20 days	Wed 5/16/18	Mon 6/4/18	676	Yes						
678	GROUTING	25 days	Tue 6/5/18	Fri 6/29/18	677	Yes						
679	PASANG HT DINDING	25 days	Tue 8/14/18	Fri 9/7/18	646SS,677,681	Yes						
680	WATER PROOFING	25 days	Sat 6/30/18	Tue 7/24/18	678	Yes						

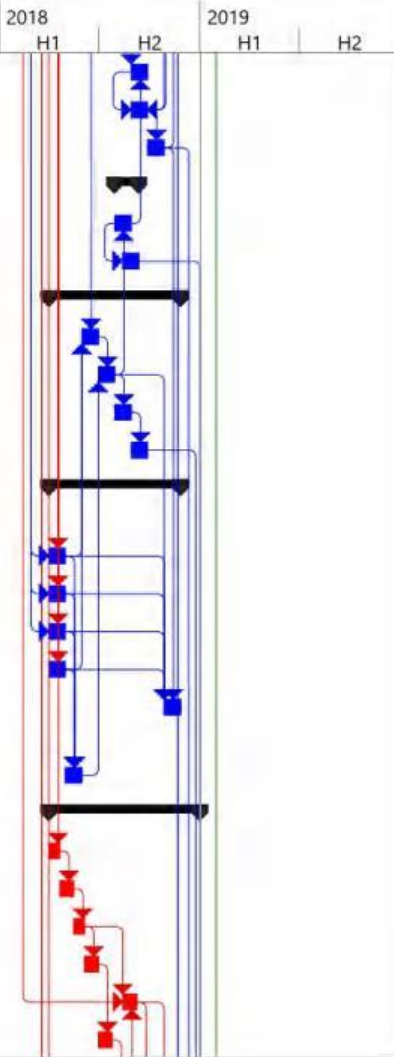

ID	Task Name	Duration	Start	Finish	Predecessors	Critical	2017		2018		2019	
							H1	H2	H1	H2	H1	H2
681	TEST WATER PROOFING	20 days	Wed 7/25/18	Mon 8/13/18	680	Yes						
682	PASANG HT LANTAI	25 days	Sun 10/28/18	Wed 11/21/18	679,681,684	Yes						
683	PASANG RANGKA PLAFOND	25 days	Sat 9/8/18	Tue 10/2/18	679	Yes						
684	TUTUP PLAFOND	25 days	Wed 10/3/18	Sat 10/27/18	683	Yes						
685	CAT PLAFOND	25 days	Sun 10/28/18	Wed 11/21/18	666FF,684	No						
686	PASANG PINTU	20 days	Thu 11/22/18	Tue 12/11/18	647,654,682	Yes						
687	PASANG SANITARY	20 days	Wed 12/12/18	Mon 12/31/18	658,686	Yes						
688	AREA FAÇADE/BALKON	125 days	Fri 3/2/18	Wed 7/4/18		No						
689	PASANG PC PANEL	25 days	Fri 3/2/18	Mon 3/26/18	644	No						
690	PASANG JENDELA ALUMUNIUM	25 days	Tue 3/27/18	Fri 4/20/18	689	No						
691	PASANG RAILING BALKON	30 days	Tue 3/27/18	Wed 4/25/18	689	No						
692	PASANG HT LANTAI	25 days	Sun 6/10/18	Wed 7/4/18	694	No						
693	WATER PROOFING	25 days	Thu 4/26/18	Sun 5/20/18	691	No						
694	TEST WATER PROOFING	20 days	Mon 5/21/18	Sat 6/9/18	693	No						
695	AREA CORIDOR	245.5 days	Fri 3/2/18	Fri 11/2/18		No						
696	Pasang Bata	25 days	Sun 4/1/18	Wed 4/25/18	644FS+30 days	No						
697	Pasang Conduit + Inbodus di Dinding	25 days	Fri 4/13/18	Tue 5/8/18	696SS+50%	No						
698	Pasang Conduit di Plafond	25 days	Fri 4/13/18	Tue 5/8/18	697SS	No						
699	Render/Plaster	25 days	Thu 4/26/18	Sun 5/20/18	697SS+50%	No						
700	Instalasi Kabel	25 days	Wed 4/18/18	Sun 5/13/18	698SS+5 days	No						
701	Instalasi MVAC	25 days	Wed 4/18/18	Sun 5/13/18	698SS+5 days	No						
702	Pipa Fire Fighting	25 days	Fri 3/2/18	Mon 3/26/18	644	No						

ID	Task Name	Duration	Start	Finish	Predecessors	Critical	2017		2018		2019	
							H1	H2	H1	H2	H1	H2
703	Test Parsial MEP dalam Plafond	20 days	Thu 6/7/18	Wed 6/27/18	704	No						
704	Rangka Plafond	25 days	Sun 5/13/18	Thu 6/7/18	700,701,702	No						
705	Tutup Plafond	25 days	Sat 6/30/18	Wed 7/25/18	703FS+3 days	No						
706	Pasang HT/Keramik	25 days	Wed 7/25/18	Sun 8/19/18	705	No						
707	Railing Tangga	25 days	Thu 4/26/18	Sun 5/20/18	696	No						
708	ME Fixture di Plafond	25 days	Thu 9/13/18	Mon 10/8/18	705,710	No						
709	ME Fixture di Dinding	25 days	Thu 9/13/18	Mon 10/8/18	708SS,710	No						
710	Pintu Besi	25 days	Sun 8/19/18	Thu 9/13/18	706	No						
711	Pengecatan	25 days	Mon 10/8/18	Fri 11/2/18	699,705,706,707,70	No						
712	Finish Lantai 11	1 day	Tue 1/1/19	Tue 1/1/19	661,687,694,711	Yes						

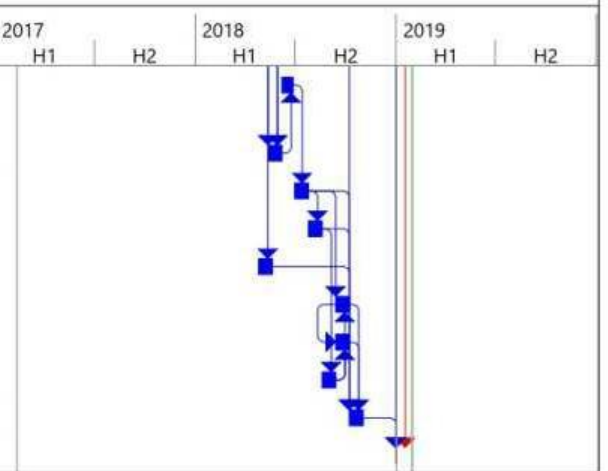

Lampiran 13. Daftar Aktivitas, *Network Planning, Predecessor* Lantai 12

PEMILIK		COMPOSITE SCHEDULE					KONSULTAN MK					
PODO MORO CITY DELI MEGAH		FINISHING-ME TOWER 3L					JAYA CM					
ID	Task Name	Duration	Start	Finish	Predecessors	Critical	2017	2018	2019			
							H1	H2	H1	H2	H1	H2
1	SCHEDULE FINISHING-ME TOWER 3L	371 days	Mon 1/1/18	Sun 1/6/19		Yes						
2	LINCOLN (Lantai LM)	371 days	Mon 1/1/18	Sun 1/6/19		Yes						
3	LANTAI 1	321 days	Mon 1/1/18	Sat 11/17/18		No						
74	LANTAI 2	321 days	Sat 1/6/18	Thu 11/22/18	35S+5 days	No						
145	LANTAI 3	321 days	Thu 1/11/18	Tue 11/27/18	74SS+5 days	No						
216	LANTAI 5	321 days	Tue 1/16/18	Sun 12/2/18	145SS+5 days	No						
287	LANTAI 6	321 days	Sun 1/21/18	Fri 12/7/18	216SS+5 days	No						
358	LANTAI 7	321 days	Fri 1/26/18	Wed 12/12/18	287SS+5 days	No						
429	LANTAI 8	321 days	Wed 1/31/18	Mon 12/17/18	358SS+5 days	No						
500	LANTAI 9	321 days	Mon 2/5/18	Sat 12/22/18	429SS+5 days	No						
571	LANTAI 10	321 days	Sat 2/10/18	Thu 12/27/18	500SS+5 days	No						
642	LANTAI 11	321 days	Thu 2/15/18	Tue 1/1/19	571SS+5 days	No						
713	LANTAI 11	321 days	Thu 2/15/18	Tue 1/1/19	571SS+5 days	No						
784	LANTAI 12	321 days	Tue 2/20/18	Sun 1/6/19	713SS+5 days	Yes						
785	AREA UNIT	285 days	Tue 2/20/18	Sat 12/1/18		Yes						
786	MARKING	15 days	Tue 2/20/18	Tue 3/6/18		Yes						
787	PEKERJAAN DINDING	270 days	Wed 3/7/18	Sat 12/1/18		Yes						
788	PASANG BATA	30 days	Wed 3/7/18	Thu 4/5/18	786	Yes						
789	PLESTER/RENDER	30 days	Sun 5/6/18	Mon 6/4/18	788,792,793,794	No						
790	CAT DINDING	30 days	Tue 6/5/18	Wed 7/4/18	789	No						
791	MEP DINDING	240 days	Fri 4/6/18	Sat 12/1/18		No						
792	ELEKTRONIK	30 days	Fri 4/6/18	Sat 5/5/18	788	No						
793	ELEKTRIKAL	30 days	Fri 4/6/18	Sat 5/5/18	788	No						
794	MVAC	30 days	Fri 4/6/18	Sat 5/5/18	788	No						
795	FIXTURES MEP DALAM DINDING	30 days	Fri 11/2/18	Sat 12/1/18	792,793,794,799,800	No						

ID	Task Name	Duration	Start	Finish	Predecessors	Critical	2017		2018		2019	
							H1	H2	H1	H2	H1	H2
796	TEST MEP	30 days	Sun 5/6/18	Mon 6/4/18	792,793,794	No						
797	PINTU KAYU	60 days	Mon 9/3/18	Thu 11/1/18		No						
798	KUSEN PINTU	30 days	Mon 9/3/18	Tue 10/2/18	789,802	No						
799	DAUN PINTU	30 days	Mon 9/3/18	Tue 10/2/18	790FF,798SS	No						
800	ACESSORIES	30 days	Wed 10/3/18	Thu 11/1/18	799	No						
801	PEKERJAAN LANTAI	44 days	Sat 8/4/18	Sun 9/16/18		No						
802	PASANG MARBEL	30 days	Sat 8/4/18	Sun 9/2/18	806	No						
803	POLES MARBEL	30 days	Sat 8/18/18	Sun 9/16/18	802SS+14 days	No						
804	PEKERJAAN PLAFOND	240 days	Fri 4/6/18	Sat 12/1/18		No						
805	PASANG RANGKA	30 days	Tue 6/5/18	Wed 7/4/18	789,810,813	No						
806	TUTUP PLAFOND	30 days	Thu 7/5/18	Fri 8/3/18	805,815	No						
807	COMPOUND	30 days	Sat 8/4/18	Sun 9/2/18	806	No						
808	CAT PLAFOND	30 days	Mon 9/3/18	Tue 10/2/18	807	No						
809	MEP DALAM PLAFOND	240 days	Fri 4/6/18	Sat 12/1/18		No						
810	ELEKTRIKAL	30 days	Fri 4/6/18	Sat 5/5/18	788,793SS	No						
811	ELEKTRONIK	30 days	Fri 4/6/18	Sat 5/5/18	788,792SS	No						
812	MVAC	30 days	Fri 4/6/18	Sat 5/5/18	788,794SS	No						
813	PLPK	30 days	Fri 4/6/18	Sat 5/5/18	788	No						
814	FIXTURE MEP DALAM PLAFOND	30 days	Fri 11/2/18	Sat 12/1/18	800,806,810,811,81	No						
815	TEST MEP	30 days	Sun 5/6/18	Mon 6/4/18	810,811,812,813	No						
816	AREA KAMAR MANDI	275 days	Fri 4/6/18	Sat 1/5/19		Yes						
817	CORING	20 days	Fri 4/6/18	Wed 4/25/18	788	Yes						
818	PASANG PIPA	25 days	Thu 4/26/18	Sun 5/20/18	817	Yes						
819	TEST BOCOR	20 days	Mon 5/21/18	Sat 6/9/18	818	Yes						
820	GROUTING	25 days	Sun 6/10/18	Wed 7/4/18	819	Yes						

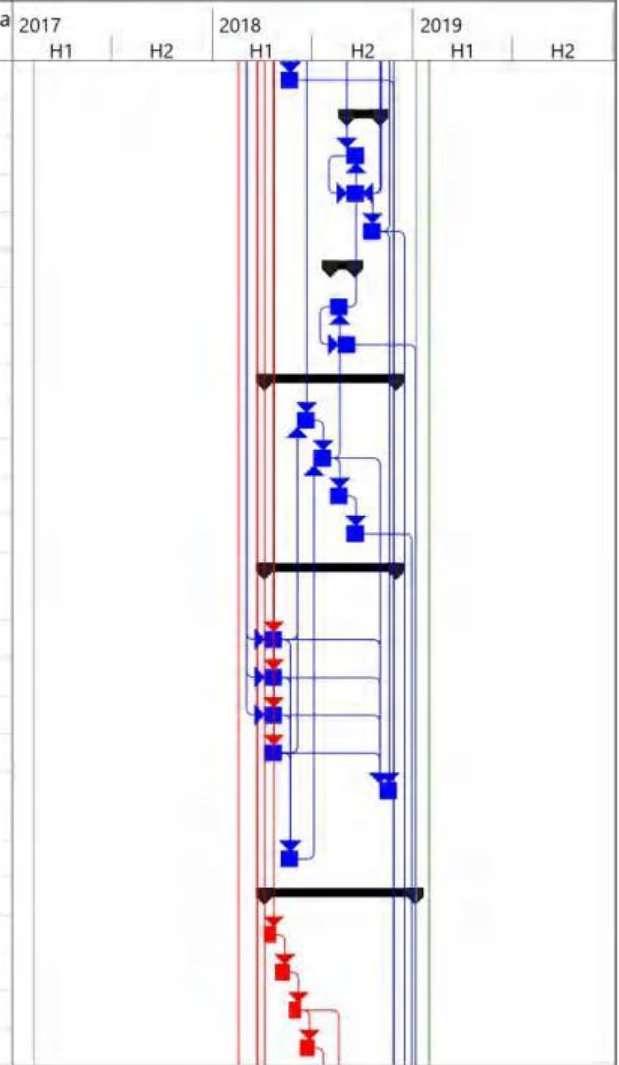

ID	Task Name	Duration	Start	Finish	Predecessors	Critical	2017		2018		2019	
							H1	H2	H1	H2	H1	H2
821	PASANG HT DINDING	25 days	Sun 8/19/18	Wed 9/12/18	788SS,819,823	Yes						
822	WATER PROOFING	25 days	Thu 7/5/18	Sun 7/29/18	820	Yes						
823	TEST WATER PROOFING	20 days	Mon 7/30/18	Sat 8/18/18	822	Yes						
824	PASANG HT LANTAI	25 days	Fri 11/2/18	Mon 11/26/18	821,823,826	Yes						
825	PASANG RANGKA PLAFOND	25 days	Thu 9/13/18	Sun 10/7/18	821	Yes						
826	TUTUP PLAFOND	25 days	Mon 10/8/18	Thu 11/1/18	825	Yes						
827	CAT PLAFOND	25 days	Fri 11/2/18	Mon 11/26/18	808FF,826	No						
828	PASANG PINTU	20 days	Tue 11/27/18	Sun 12/16/18	789,796,824	Yes						
829	PASANG SANITARY	20 days	Mon 12/17/18	Sat 1/5/19	800,828	Yes						
830	AREA FAÇADE/BALKON	125 days	Wed 3/7/18	Mon 7/9/18		No						
831	PASANG PC PANEL	25 days	Wed 3/7/18	Sat 3/31/18	786	No						
832	PASANG JENDELA ALUMUNIUM	25 days	Sun 4/1/18	Wed 4/25/18	831	No						
833	PASANG RAILING BALKON	30 days	Sun 4/1/18	Mon 4/30/18	831	No						
834	PASANG HT LANTAI	25 days	Fri 6/15/18	Mon 7/9/18	836	No						
835	WATER PROOFING	25 days	Tue 5/1/18	Fri 5/25/18	833	No						
836	TEST WATER PROOFING	20 days	Sat 5/26/18	Thu 6/14/18	835	No						
837	AREA CORIDOR	245.5 days	Wed 3/7/18	Wed 11/7/18		No						
838	Pasang Bata	25 days	Fri 4/6/18	Mon 4/30/18	786FS+30 days	No						
839	Pasang Conduit + Inbodus di Dinding	25 days	Wed 4/18/18	Sun 5/13/18	838SS+50%	No						
840	Pasang Conduit di Plafond	25 days	Wed 4/18/18	Sun 5/13/18	839SS	No						
841	Render/Plaster	25 days	Tue 5/1/18	Fri 5/25/18	839SS+50%	No						
842	Instalasi Kabel	25 days	Mon 4/23/18	Fri 5/18/18	840SS+5 days	No						

ID	Task Name	Duration	Start	Finish	Predecessors	Critical	2017		2018		2019	
							H1	H2	H1	H2	H1	H2
843	Instalasi MVAC	25 days	Mon 4/23/18	Fri 5/18/18	840SS+5 days	No						
844	Pipa Fire Fighting	25 days	Wed 3/7/18	Sat 3/31/18	786	No						
845	Test Parsial MEP dalam Plafond	20 days	Tue 6/12/18	Mon 7/2/18	846	No						
846	Rangka Plafond	25 days	Fri 5/18/18	Tue 6/12/18	842,843,844	No						
847	Tutup Plafond	25 days	Thu 7/5/18	Mon 7/30/18	845FS+3 days	No						
848	Pasang HT/Keramik	25 days	Mon 7/30/18	Fri 8/24/18	847	No						
849	Railing Tangga	25 days	Tue 5/1/18	Fri 5/25/18	838	No						
850	ME Fixture di Plafond	25 days	Tue 9/18/18	Sat 10/13/18	847,852	No						
851	ME Fixture di Dinding	25 days	Tue 9/18/18	Sat 10/13/18	850SS,852	No						
852	Pintu Besi	25 days	Fri 8/24/18	Tue 9/18/18	848	No						
853	Pengecatan	25 days	Sat 10/13/18	Wed 11/7/18	841,847,848,849,850	No						
854	Finish Lantai 12	1 day	Sun 1/6/19	Sun 1/6/19	803,829,836,853	Yes						

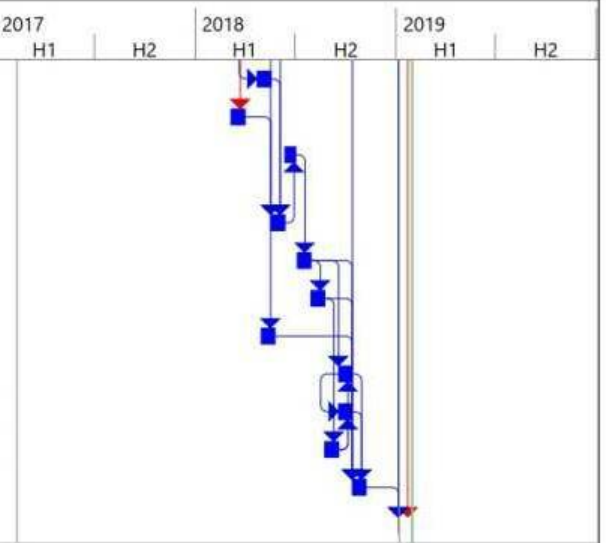

Lampiran 14. Daftar Aktivitas, *Network Planning, Predecessor* Lantai 13

PEMILIK		COMPOSITE SCHEDULE					KONSULTAN MK									
PODO MORO CITY		FINISHING-ME TOWER 3L					JAYA CM									
ID	Task Name	Duration	Start	Finish	Predecessors	Critical	2017				2018				2019	
							Q1	Q2	Q3	Q4	Q1	Q2	Q3	Q4	Q1	Q2
1	SCHEDULE FINISHING-ME TOWER 3L	376 days	Mon 1/1/18	Fri 1/11/19		Yes										
2	LINCOLN (Lantai LM)	376 days	Mon 1/1/18	Fri 1/11/19		Yes										
3	LANTAI 1	321 days	Mon 1/1/18	Sat 11/17/18		No										
74	LANTAI 2	321 days	Sat 1/6/18	Thu 11/22/18	35S+5 days	No										
145	LANTAI 3	321 days	Thu 1/11/18	Tue 11/27/18	74SS+5 days	No										
216	LANTAI 5	321 days	Tue 1/16/18	Sun 12/2/18	145SS+5 days	No										
287	LANTAI 6	321 days	Sun 1/21/18	Fri 12/7/18	216SS+5 days	No										
358	LANTAI 7	321 days	Fri 1/26/18	Wed 12/12/18	287SS+5 days	No										
429	LANTAI 8	321 days	Wed 1/31/18	Mon 12/17/18	358SS+5 days	No										
500	LANTAI 9	321 days	Mon 2/5/18	Sat 12/22/18	429SS+5 days	No										
571	LANTAI 10	321 days	Sat 2/10/18	Thu 12/27/18	500SS+5 days	No										
642	LANTAI 11	321 days	Thu 2/15/18	Tue 1/1/19	571SS+5 days	No										
713	LANTAI 11	321 days	Thu 2/15/18	Tue 1/1/19	571SS+5 days	No										
784	LANTAI 12	321 days	Tue 2/20/18	Sun 1/6/19	713SS+5 days	No										
855	LANTAI 13	321 days	Sun 2/25/18	Fri 1/11/19	784SS+5 days	Yes										
856	AREA UNIT	285 days	Sun 2/25/18	Thu 12/6/18		Yes										
857	MARKING	15 days	Sun 2/25/18	Sun 3/11/18		Yes										
858	PEKERJAAN DINDING	270 days	Mon 3/12/18	Thu 12/6/18		Yes										
859	PASANG BATA	30 days	Mon 3/12/18	Tue 4/10/18	857	Yes										
860	PLESTER/RENDER	30 days	Fri 5/11/18	Sat 6/9/18	859,863,864,865	No										
861	CAT DINDING	30 days	Sun 6/10/18	Mon 7/9/18	860	No										
862	MEP DINDING	240 days	Wed 4/11/18	Thu 12/6/18		No										
863	ELEKTRONIK	30 days	Wed 4/11/18	Thu 5/10/18	859	No										
864	ELEKTRIKAL	30 days	Wed 4/11/18	Thu 5/10/18	859	No										
865	MVAC	30 days	Wed 4/11/18	Thu 5/10/18	859	No										



ID	Task Name	Duration	Start	Finish	Predecessors	Critical	2017		2018				2019			
							Q1	Q2	Q3	Q4	Q1	Q2	Q3	Q4	Q1	Q2
866	FIXTURES MEP DALAM DINDING	30 days	Wed 11/7/18	Thu 12/6/18	863,864,865,870,87	No										
867	TEST MEP	30 days	Fri 5/11/18	Sat 6/9/18	863,864,865	No										
868	PINTU KAYU	60 days	Sat 9/8/18	Tue 11/6/18		No										
869	KUSEN PINTU	30 days	Sat 9/8/18	Sun 10/7/18	860,873	No										
870	DAUN PINTU	30 days	Sat 9/8/18	Sun 10/7/18	861FF,869SS	No										
871	ACESSORIES	30 days	Mon 10/8/18	Tue 11/6/18	870	No										
872	PEKERJAAN LANTAI	44 days	Thu 8/9/18	Fri 9/21/18		No										
873	PASANG MARBEL	30 days	Thu 8/9/18	Fri 9/7/18	877	No										
874	POLES MARBEL	30 days	Thu 8/23/18	Fri 9/21/18	873SS+14 days	No										
875	PEKERJAAN PLAFOND	240 days	Wed 4/11/18	Thu 12/6/18		No										
876	PASANG RANGKA	30 days	Sun 6/10/18	Mon 7/9/18	860,881,884	No										
877	TUTUP PLAFOND	30 days	Tue 7/10/18	Wed 8/8/18	876,886	No										
878	COMPOUND	30 days	Thu 8/9/18	Fri 9/7/18	877	No										
879	CAT PLAFOND	30 days	Sat 9/8/18	Sun 10/7/18	878	No										
880	MEP DALAM PLAFOND	240 days	Wed 4/11/18	Thu 12/6/18		No										
881	ELEKTRIKAL	30 days	Wed 4/11/18	Thu 5/10/18	859,864SS	No										
882	ELEKTRONIK	30 days	Wed 4/11/18	Thu 5/10/18	859,863SS	No										
883	MVAC	30 days	Wed 4/11/18	Thu 5/10/18	859,865SS	No										
884	PLPK	30 days	Wed 4/11/18	Thu 5/10/18	859	No										
885	FIXTURE MEP DALAM PLAFOND	30 days	Wed 11/7/18	Thu 12/6/18	871,877,881,882,88	No										
886	TEST MEP	30 days	Fri 5/11/18	Sat 6/9/18	881,882,883,884	No										
887	AREA KAMAR MANDI	275 days	Wed 4/11/18	Thu 1/10/19		Yes										
888	CORING	20 days	Wed 4/11/18	Mon 4/30/18	859	Yes										
889	PASANG PIPA	25 days	Tue 5/1/18	Fri 5/25/18	888	Yes										

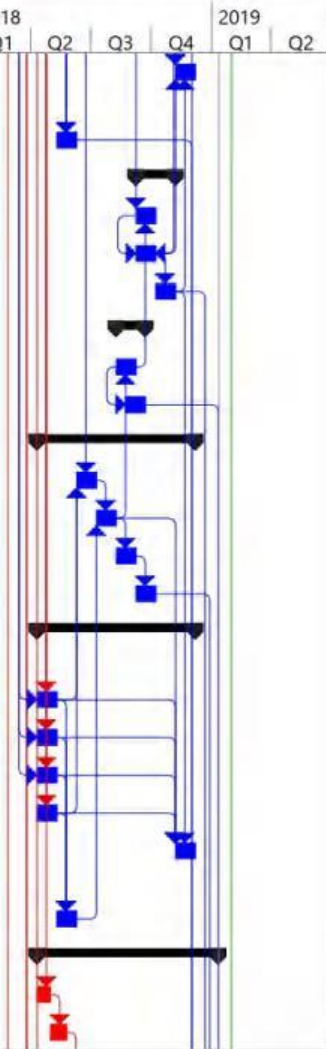

ID	Task Name	Duration	Start	Finish	Predecessors	Critical	2017		2018				2019			
							Q1	Q2	Q3	Q4	Q1	Q2	Q3	Q4	Q1	Q2
890	TEST BOCOR	20 days	Sat 5/26/18	Thu 6/14/18	889	Yes										
891	GROUTING	25 days	Fri 6/15/18	Mon 7/9/18	890	Yes										
892	PASANG HT DINDING	25 days	Fri 8/24/18	Mon 9/17/18	859SS,890,894	Yes										
893	WATER PROOFING	25 days	Tue 7/10/18	Fri 8/3/18	891	Yes										
894	TEST WATER PROOFING	20 days	Sat 8/4/18	Thu 8/23/18	893	Yes										
895	PASANG HT LANTAI	25 days	Wed 11/7/18	Sat 12/1/18	892,894,897	Yes										
896	PASANG RANGKA PLAFOND	25 days	Tue 9/18/18	Fri 10/12/18	892	Yes										
897	TUTUP PLAFOND	25 days	Sat 10/13/18	Tue 11/6/18	896	Yes										
898	CAT PLAFOND	25 days	Wed 11/7/18	Sat 12/1/18	879FF,897	No										
899	PASANG PINTU	20 days	Sun 12/2/18	Fri 12/21/18	860,867,895	Yes										
900	PASANG SANITARY	20 days	Sat 12/22/18	Thu 1/10/19	871,899	Yes										
901	AREA FAÇADE/BALKON	125 days	Mon 3/12/18	Sat 7/14/18		No										
902	PASANG PC PANEL	25 days	Mon 3/12/18	Thu 4/5/18	857	No										
903	PASANG JENDELA ALUMUNIUM	25 days	Fri 4/6/18	Mon 4/30/18	902	No										
904	PASANG RAILING BALKON	30 days	Fri 4/6/18	Sat 5/5/18	902	No										
905	PASANG HT LANTAI	25 days	Wed 6/20/18	Sat 7/14/18	907	No										
906	WATER PROOFING	25 days	Sun 5/6/18	Wed 5/30/18	904	No										
907	TEST WATER PROOFING	20 days	Thu 5/31/18	Tue 6/19/18	906	No										
908	AREA CORIDOR	245.5 days	Mon 3/12/18	Mon 11/12/18		No										
909	Pasang Bata	25 days	Wed 4/11/18	Sat 5/5/18	857FS+30 days	No										
910	Pasang Conduit + Inbodus di Dinding	25 days	Mon 4/23/18	Fri 5/18/18	909SS+50%	No										
911	Pasang Conduit di Plafond	25 days	Mon 4/23/18	Fri 5/18/18	910SS	No										

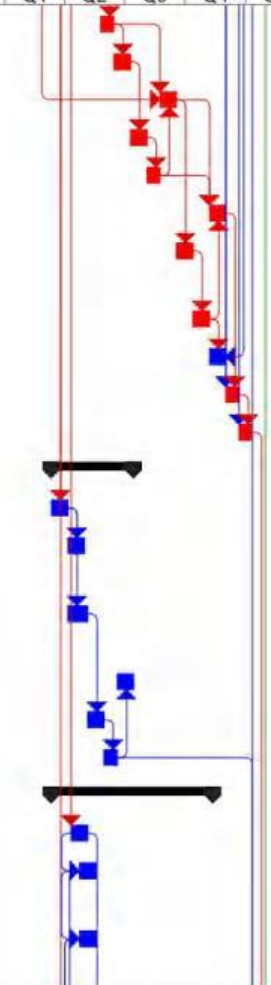

ID	Task Name	Duration	Start	Finish	Predecessors	Critical	2017		2018				2019			
							Q1	Q2	Q3	Q4	Q1	Q2	Q3	Q4	Q1	Q2
912	Render/Plaster	25 days	Sun 5/6/18	Wed 5/30/18	910SS+50%	No										
913	Instalasi Kabel	25 days	Sat 4/28/18	Wed 5/23/18	911SS+5 days	No										
914	Instalasi MVAC	25 days	Sat 4/28/18	Wed 5/23/18	911SS+5 days	No										
915	Pipa Fire Fighting	25 days	Mon 3/12/18	Thu 4/5/18	857	No										
916	Test Parsial MEP dalam Plafond	20 days	Sun 6/17/18	Sat 7/7/18	917	No										
917	Rangka Plafond	25 days	Wed 5/23/18	Sun 6/17/18	913,914,915	No										
918	Tutup Plafond	25 days	Tue 7/10/18	Sat 8/4/18	916FS+3 days	No										
919	Pasang HT/Keramik	25 days	Sat 8/4/18	Wed 8/29/18	918	No										
920	Railing Tangga	25 days	Sun 5/6/18	Wed 5/30/18	909	No										
921	ME Fixture di Plafond	25 days	Sun 9/23/18	Thu 10/18/18	918,923	No										
922	ME Fixture di Dinding	25 days	Sun 9/23/18	Thu 10/18/18	921SS,923	No										
923	Pintu Besi	25 days	Wed 8/29/18	Sun 9/23/18	919	No										
924	Pengecatan	25 days	Thu 10/18/18	Mon 11/12/18	912,918,919,920,92	No										
925	Finish Lantai 13	1 day	Fri 1/11/19	Fri 1/11/19	874,900,907,924	Yes										

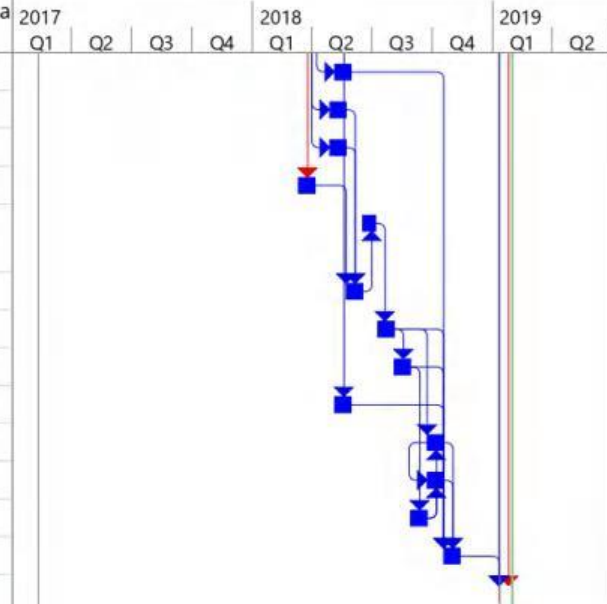

Lampiran 15. Daftar Aktivitas, *Network Planning, Predecessor* Lantai 14

PEMILIK		COMPOSITE SCHEDULE					KONSULTAN MK									
PODO MORO CITY DELI MEGAH		FINISHING-ME TOWER 3L					JAYA CM									
ID	Task Name	Duration	Start	Finish	Predecessors	Critical	2017				2018				2019	
							Q1	Q2	Q3	Q4	Q1	Q2	Q3	Q4	Q1	Q2
1	SCHEDULE FINISHING-ME TOWER 3L	381 days	Mon 1/1/18	Wed 1/16/19		Yes										
2	LINCOLN (Lantai LM)	381 days	Mon 1/1/18	Wed 1/16/19		Yes										
3	LANTAI 1	321 days	Mon 1/1/18	Sat 11/17/18		No										
74	LANTAI 2	321 days	Sat 1/6/18	Thu 11/22/18	3SS+5 days	No										
145	LANTAI 3	321 days	Thu 1/11/18	Tue 11/27/18	74SS+5 days	No										
216	LANTAI 5	321 days	Tue 1/16/18	Sun 12/2/18	145SS+5 days	No										
287	LANTAI 6	321 days	Sun 1/21/18	Fri 12/7/18	216SS+5 days	No										
358	LANTAI 7	321 days	Fri 1/26/18	Wed 12/12/18	287SS+5 days	No										
429	LANTAI 8	321 days	Wed 1/31/18	Mon 12/17/18	358SS+5 days	No										
500	LANTAI 9	321 days	Mon 2/5/18	Sat 12/22/18	429SS+5 days	No										
571	LANTAI 10	321 days	Sat 2/10/18	Thu 12/27/18	500SS+5 days	No										
642	LANTAI 11	321 days	Thu 2/15/18	Tue 1/1/19	571SS+5 days	No										
713	LANTAI 11	321 days	Thu 2/15/18	Tue 1/1/19	571SS+5 days	No										
784	LANTAI 12	321 days	Tue 2/20/18	Sun 1/6/19	713SS+5 days	No										
855	LANTAI 13	321 days	Sun 2/25/18	Fri 1/11/19	784SS+5 days	No										
926	LANTAI 14	321 days	Fri 3/2/18	Wed 1/16/19	855SS+5 days	Yes										
927	AREA UNIT	285 days	Fri 3/2/18	Tue 12/11/18		Yes										
928	MARKING	15 days	Fri 3/2/18	Fri 3/16/18		Yes										
929	PEKERJAAN DINDING	270 days	Sat 3/17/18	Tue 12/11/18		Yes										
930	PASANG BATA	30 days	Sat 3/17/18	Sun 4/15/18	928	Yes										
931	PLESTER/RENDER	30 days	Wed 5/16/18	Thu 6/14/18	930,934,935,936	No										
932	CAT DINDING	30 days	Fri 6/15/18	Sat 7/14/18	931	No										
933	MEP DINDING	240 days	Mon 4/16/18	Tue 12/11/18		No										
934	ELEKTRONIK	30 days	Mon 4/16/18	Tue 5/15/18	930	No										
935	ELEKTRIKAL	30 days	Mon 4/16/18	Tue 5/15/18	930	No										
936	MVAC	30 days	Mon 4/16/18	Tue 5/15/18	930	No										

ID	Task Name	Duration	Start	Finish	Predecessors	Critical	2017		2018				2019			
							Q1	Q2	Q3	Q4	Q1	Q2	Q3	Q4	Q1	Q2
937	FIXTURES MEP DALAM DINDING	30 days	Mon 11/12/18	Tue 12/11/18	934,935,936,941,94	No										
938	TEST MEP	30 days	Wed 5/16/18	Thu 6/14/18	934,935,936	No										
939	PINTU KAYU	60 days	Thu 9/13/18	Sun 11/11/18		No										
940	KUSEN PINTU	30 days	Thu 9/13/18	Fri 10/12/18	931,944	No										
941	DAUN PINTU	30 days	Thu 9/13/18	Fri 10/12/18	932FF,940SS	No										
942	ACESSORIES	30 days	Sat 10/13/18	Sun 11/11/18	941	No										
943	PEKERJAAN LANTAI	44 days	Tue 8/14/18	Wed 9/26/18		No										
944	PASANG MARBEL	30 days	Tue 8/14/18	Wed 9/12/18	948	No										
945	POLES MARBEL	30 days	Tue 8/28/18	Wed 9/26/18	944SS+14 days	No										
946	PEKERJAAN PLAFOND	240 days	Mon 4/16/18	Tue 12/11/18		No										
947	PASANG RANGKA	30 days	Fri 6/15/18	Sat 7/14/18	931,952,955	No										
948	TUTUP PLAFOND	30 days	Sun 7/15/18	Mon 8/13/18	947,957	No										
949	COMPOUND	30 days	Tue 8/14/18	Wed 9/12/18	948	No										
950	CAT PLAFOND	30 days	Thu 9/13/18	Fri 10/12/18	949	No										
951	MEP DALAM PLAFOND	240 days	Mon 4/16/18	Tue 12/11/18		No										
952	ELEKTRIKAL	30 days	Mon 4/16/18	Tue 5/15/18	930,935SS	No										
953	ELEKTRONIK	30 days	Mon 4/16/18	Tue 5/15/18	930,934SS	No										
954	MVAC	30 days	Mon 4/16/18	Tue 5/15/18	930,936SS	No										
955	PLPK	30 days	Mon 4/16/18	Tue 5/15/18	930	No										
956	FIXTURE MEP DALAM PLAFOND	30 days	Mon 11/12/18	Tue 12/11/18	942,948,952,953,95	No										
957	TEST MEP	30 days	Wed 5/16/18	Thu 6/14/18	952,953,954,955	No										
958	AREA KAMAR MANDI	275 days	Mon 4/16/18	Tue 1/15/19		Yes										
959	CORING	20 days	Mon 4/16/18	Sat 5/5/18	930	Yes										
960	PASANG PIPA	25 days	Sun 5/6/18	Wed 5/30/18	959	Yes										

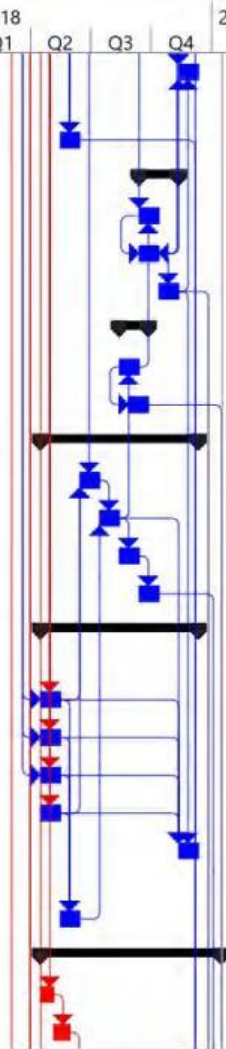

ID	Task Name	Duration	Start	Finish	Predecessors	Critical	2017				2018				2019	
							Q1	Q2	Q3	Q4	Q1	Q2	Q3	Q4	Q1	Q2
961	TEST BOCOR	20 days	Thu 5/31/18	Tue 6/19/18	960	Yes										
962	GROUTING	25 days	Wed 6/20/18	Sat 7/14/18	961	Yes										
963	PASANG HT DINDING	25 days	Wed 8/29/18	Sat 9/22/18	930SS,961,965	Yes										
964	WATER PROOFING	25 days	Sun 7/15/18	Wed 8/8/18	962	Yes										
965	TEST WATER PROOFING	20 days	Thu 8/9/18	Tue 8/28/18	964	Yes										
966	PASANG HT LANTAI	25 days	Mon 11/12/18	Thu 12/6/18	963,965,968	Yes										
967	PASANG RANGKA PLAFOND	25 days	Sun 9/23/18	Wed 10/17/18	963	Yes										
968	TUTUP PLAFOND	25 days	Thu 10/18/18	Sun 11/11/18	967	Yes										
969	CAT PLAFOND	25 days	Mon 11/12/18	Thu 12/6/18	950FF,968	No										
970	PASANG PINTU	20 days	Fri 12/7/18	Wed 12/26/18	931,938,966	Yes										
971	PASANG SANITARY	20 days	Thu 12/27/18	Tue 1/15/19	942,970	Yes										
972	AREA FAÇADE/BALKON	125 days	Sat 3/17/18	Thu 7/19/18		No										
973	PASANG PC PANEL	25 days	Sat 3/17/18	Tue 4/10/18	928	No										
974	PASANG JENDELA ALUMUNIUM	25 days	Wed 4/11/18	Sat 5/5/18	973	No										
975	PASANG RAILING BALKON	30 days	Wed 4/11/18	Thu 5/10/18	973	No										
976	PASANG HT LANTAI	25 days	Mon 6/25/18	Thu 7/19/18	978	No										
977	WATER PROOFING	25 days	Fri 5/11/18	Mon 6/4/18	975	No										
978	TEST WATER PROOFING	20 days	Tue 6/5/18	Sun 6/24/18	977	No										
979	AREA CORIDOR	245.5 days	Sat 3/17/18	Sat 11/17/18		No										
980	Pasang Bata	25 days	Mon 4/16/18	Thu 5/10/18	928FS+30 days	No										
981	Pasang Conduit + Inbodus di Dinding	25 days	Sat 4/28/18	Wed 5/23/18	980SS+50%	No										
982	Pasang Conduit di Plafond	25 days	Sat 4/28/18	Wed 5/23/18	981SS	No										

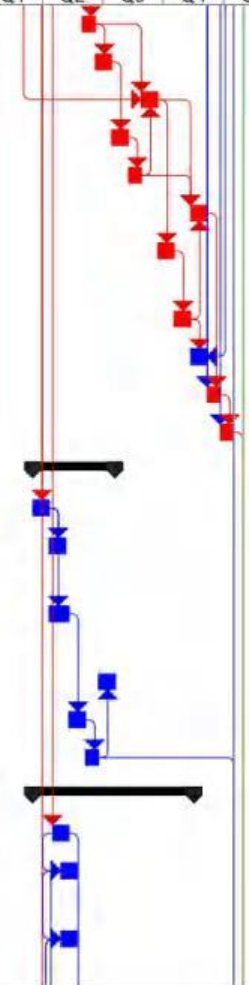

ID	Task Name	Duration	Start	Finish	Predecessors	Critical	2017		2018				2019			
							Q1	Q2	Q3	Q4	Q1	Q2	Q3	Q4	Q1	Q2
983	Render/Plaster	25 days	Fri 5/11/18	Mon 6/4/18	981SS+50%	No										
984	Instalasi Kabel	25 days	Thu 5/3/18	Mon 5/28/18	982SS+5 days	No										
985	Instalasi MVAC	25 days	Thu 5/3/18	Mon 5/28/18	982SS+5 days	No										
986	Pipa Fire Fighting	25 days	Sat 3/17/18	Tue 4/10/18	928	No										
987	Test Parsial MEP dalam Plafond	20 days	Fri 6/22/18	Thu 7/12/18	988	No										
988	Rangka Plafond	25 days	Mon 5/28/18	Fri 6/22/18	984,985,986	No										
989	Tutup Plafond	25 days	Sun 7/15/18	Thu 8/9/18	987FS+3 days	No										
990	Pasang HT/Keramik	25 days	Thu 8/9/18	Mon 9/3/18	989	No										
991	Railing Tangga	25 days	Fri 5/11/18	Mon 6/4/18	980	No										
992	ME Fixture di Plafond	25 days	Fri 9/28/18	Tue 10/23/18	989,994	No										
993	ME Fixture di Dinding	25 days	Fri 9/28/18	Tue 10/23/18	992SS,994	No										
994	Pintu Besi	25 days	Mon 9/3/18	Fri 9/28/18	990	No										
995	Pengecatan	25 days	Tue 10/23/18	Sat 11/17/18	983,989,990,991,99	No										
996	Finish Lantai 14	1 day	Wed 1/16/19	Wed 1/16/19	945,971,978,995	Yes										

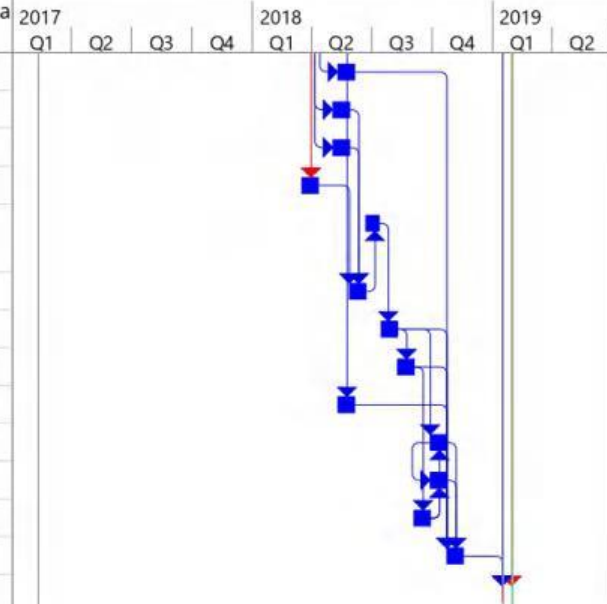

Lampiran 16. Daftar Aktivitas, *Network Planning, Predecessor* Lantai 15

PEMILIK		COMPOSITE SCHEDULE					KONSULTAN MK									
PODO MORO CITY DELI MEGAH		FINISHING-ME TOWER 3L					JAYA CM									
ID	Task Name	Duration	Start	Finish	Predecessors	Critical	2017				2018				2019	
							Q1	Q2	Q3	Q4	Q1	Q2	Q3	Q4	Q1	Q2
1	SCHEDULE FINISHING-ME TOWER 3L	386 days	Mon 1/1/18	Mon 1/21/19		Yes										
2	LINCOLN (Lantai LM)	386 days	Mon 1/1/18	Mon 1/21/19		Yes										
3	LANTAI 1	321 days	Mon 1/1/18	Sat 11/17/18		No										
74	LANTAI 2	321 days	Sat 1/6/18	Thu 11/22/18	35S+5 days	No										
145	LANTAI 3	321 days	Thu 1/11/18	Tue 11/27/18	74SS+5 days	No										
216	LANTAI 5	321 days	Tue 1/16/18	Sun 12/2/18	145SS+5 days	No										
287	LANTAI 6	321 days	Sun 1/21/18	Fri 12/7/18	216SS+5 days	No										
358	LANTAI 7	321 days	Fri 1/26/18	Wed 12/12/18	287SS+5 days	No										
429	LANTAI 8	321 days	Wed 1/31/18	Mon 12/17/18	358SS+5 days	No										
500	LANTAI 9	321 days	Mon 2/5/18	Sat 12/22/18	429SS+5 days	No										
571	LANTAI 10	321 days	Sat 2/10/18	Thu 12/27/18	500SS+5 days	No										
642	LANTAI 11	321 days	Thu 2/15/18	Tue 1/1/19	571SS+5 days	No										
713	LANTAI 11	321 days	Thu 2/15/18	Tue 1/1/19	571SS+5 days	No										
784	LANTAI 12	321 days	Tue 2/20/18	Sun 1/6/19	713SS+5 days	No										
855	LANTAI 13	321 days	Sun 2/25/18	Fri 1/11/19	784SS+5 days	No										
926	LANTAI 14	321 days	Fri 3/2/18	Wed 1/16/19	855SS+5 days	No										
997	LANTAI 15	321 days	Wed 3/7/18	Mon 1/21/19	926SS+5 days	Yes										
998	AREA UNIT	285 days	Wed 3/7/18	Sun 12/16/18		Yes										
999	MARKING	15 days	Wed 3/7/18	Wed 3/21/18		Yes										
1000	PEKERJAAN DINDING	270 days	Thu 3/22/18	Sun 12/16/18		Yes										
1001	PASANG BATA	30 days	Thu 3/22/18	Fri 4/20/18	999	Yes										
1002	PLESTER/RENDER	30 days	Mon 5/21/18	Tue 6/19/18	1001,1005,1006,100	No										
1003	CAT DINDING	30 days	Wed 6/20/18	Thu 7/19/18	1002	No										
1004	MEP DINDING	240 days	Sat 4/21/18	Sun 12/16/18		No										
1005	ELEKTRONIK	30 days	Sat 4/21/18	Sun 5/20/18	1001	No										
1006	ELEKTRIKAL	30 days	Sat 4/21/18	Sun 5/20/18	1001	No										

ID	Task Name	Duration	Start	Finish	Predecessors	Critical	2017		2018				2019			
							Q1	Q2	Q3	Q4	Q1	Q2	Q3	Q4	Q1	Q2
1007	MVAC	30 days	Sat 4/21/18	Sun 5/20/18	1001	No										
1008	FIXTURES MEP DALAM DINDING	30 days	Sat 11/17/18	Sun 12/16/18	1005,1006,1007,10	No										
1009	TEST MEP	30 days	Mon 5/21/18	Tue 6/19/18	1005,1006,1007	No										
1010	PINTU KAYU	60 days	Tue 9/18/18	Fri 11/16/18		No										
1011	KUSEN PINTU	30 days	Tue 9/18/18	Wed 10/17/18	1002,1015	No										
1012	DAUN PINTU	30 days	Tue 9/18/18	Wed 10/17/18	1003FF,1011SS	No										
1013	ACESSORIES	30 days	Thu 10/18/18	Fri 11/16/18	1012	No										
1014	PEKERJAAN LANTAI	44 days	Sun 8/19/18	Mon 10/1/18		No										
1015	PASANG MARBEL	30 days	Sun 8/19/18	Mon 9/17/18	1019	No										
1016	POLES MARBEL	30 days	Sun 9/2/18	Mon 10/1/18	1015SS+14 days	No										
1017	PEKERJAAN PLAFOND	240 days	Sat 4/21/18	Sun 12/16/18		No										
1018	PASANG RANGKA	30 days	Wed 6/20/18	Thu 7/19/18	1002,1023,1026	No										
1019	TUTUP PLAFOND	30 days	Fri 7/20/18	Sat 8/18/18	1018,1028	No										
1020	COMPOUND	30 days	Sun 8/19/18	Mon 9/17/18	1019	No										
1021	CAT PLAFOND	30 days	Tue 9/18/18	Wed 10/17/18	1020	No										
1022	MEP DALAM PLAFOND	240 days	Sat 4/21/18	Sun 12/16/18		No										
1023	ELEKTRIKAL	30 days	Sat 4/21/18	Sun 5/20/18	1001,1006SS	No										
1024	ELEKTRONIK	30 days	Sat 4/21/18	Sun 5/20/18	1001,1005SS	No										
1025	MVAC	30 days	Sat 4/21/18	Sun 5/20/18	1001,1007SS	No										
1026	PLPK	30 days	Sat 4/21/18	Sun 5/20/18	1001	No										
1027	FIXTURE MEP DALAM PLAFOND	30 days	Sat 11/17/18	Sun 12/16/18	1013,1019,1023,10	No										
1028	TEST MEP	30 days	Mon 5/21/18	Tue 6/19/18	1023,1024,1025,10	No										
1029	AREA KAMAR MANDI	275 days	Sat 4/21/18	Sun 1/20/19		Yes										
1030	CORING	20 days	Sat 4/21/18	Thu 5/10/18	1001	Yes										

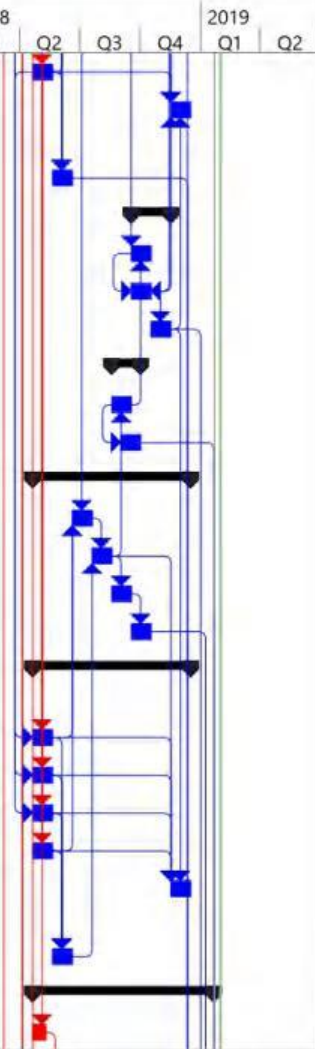

ID	Task Name	Duration	Start	Finish	Predecessors	Critical	2017		2018				2019				
							Q1	Q2	Q3	Q4	Q1	Q2	Q3	Q4	Q1	Q2	
1031	PASANG PIPA	25 days	Fri 5/11/18	Mon 6/4/18	1030	Yes											
1032	TEST BOCOR	20 days	Tue 6/5/18	Sun 6/24/18	1031	Yes											
1033	GROUTING	25 days	Mon 6/25/18	Thu 7/19/18	1032	Yes											
1034	PASANG HT DINDING	25 days	Mon 9/3/18	Thu 9/27/18	1001SS,1032,1036	Yes											
1035	WATER PROOFING	25 days	Fri 7/20/18	Mon 8/13/18	1033	Yes											
1036	TEST WATER PROOFING	20 days	Tue 8/14/18	Sun 9/2/18	1035	Yes											
1037	PASANG HT LANTAI	25 days	Sat 11/17/18	Tue 12/11/18	1034,1036,1039	Yes											
1038	PASANG RANGKA PLAFOND	25 days	Fri 9/28/18	Mon 10/22/18	1034	Yes											
1039	TUTUP PLAFOND	25 days	Tue 10/23/18	Fri 11/16/18	1038	Yes											
1040	CAT PLAFOND	25 days	Sat 11/17/18	Tue 12/11/18	1021FF,1039	No											
1041	PASANG PINTU	20 days	Wed 12/12/18	Mon 12/31/18	1002,1009,1037	Yes											
1042	PASANG SANITARY	20 days	Tue 1/1/19	Sun 1/20/19	1013,1041	Yes											
1043	AREA FAÇADE/BALKON	125 days	Thu 3/22/18	Tue 7/24/18		No											
1044	PASANG PC PANEL	25 days	Thu 3/22/18	Sun 4/15/18	999	No											
1045	PASANG JENDELA ALUMUNIUM	25 days	Mon 4/16/18	Thu 5/10/18	1044	No											
1046	PASANG RAILING BALKON	30 days	Mon 4/16/18	Tue 5/15/18	1044	No											
1047	PASANG HT LANTAI	25 days	Sat 6/30/18	Tue 7/24/18	1049	No											
1048	WATER PROOFING	25 days	Wed 5/16/18	Sat 6/9/18	1046	No											
1049	TEST WATER PROOFING	20 days	Sun 6/10/18	Fri 6/29/18	1048	No											
1050	AREA CORIDOR	245.5 days	Thu 3/22/18	Thu 11/22/18		No											
1051	Pasang Bata	25 days	Sat 4/21/18	Tue 5/15/18	999FS+30 days	No											
1052	Pasang Conduit + Inbodus di Dinding	25 days	Thu 5/3/18	Mon 5/28/18	1051SS+50%	No											

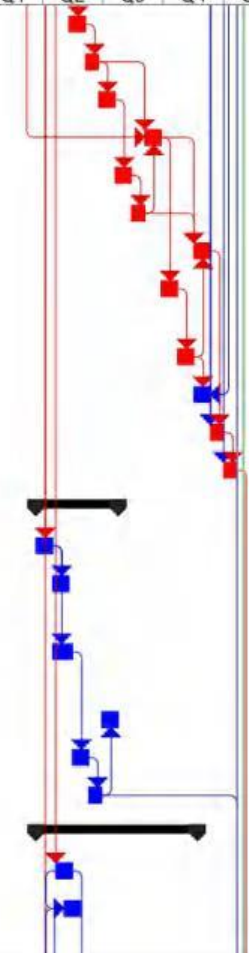

ID	Task Name	Duration	Start	Finish	Predecessors	Critical	2017		2018				2019			
							Q1	Q2	Q3	Q4	Q1	Q2	Q3	Q4	Q1	Q2
1053	Pasang Conduit di Plafond	25 days	Thu 5/3/18	Mon 5/28/18	1052SS	No										
1054	Render/Plaster	25 days	Wed 5/16/18	Sat 6/9/18	1052SS+50%	No										
1055	Instalasi Kabel	25 days	Tue 5/8/18	Sat 6/2/18	1053SS+5 days	No										
1056	Instalasi MVAC	25 days	Tue 5/8/18	Sat 6/2/18	1053SS+5 days	No										
1057	Pipa Fire Fighting	25 days	Thu 3/22/18	Sun 4/15/18	999	No										
1058	Test Parsial MEP dalam Plafond	20 days	Wed 6/27/18	Tue 7/17/18	1059	No										
1059	Rangka Plafond	25 days	Sat 6/2/18	Wed 6/27/18	1055,1056,1057	No										
1060	Tutup Plafond	25 days	Fri 7/20/18	Tue 8/14/18	1058FS+3 days	No										
1061	Pasang HT/Keramik	25 days	Tue 8/14/18	Sat 9/8/18	1060	No										
1062	Railing Tangga	25 days	Wed 5/16/18	Sat 6/9/18	1051	No										
1063	ME Fixture di Plafond	25 days	Wed 10/3/18	Sun 10/28/18	1060,1065	No										
1064	ME Fixture di Dinding	25 days	Wed 10/3/18	Sun 10/28/18	1063SS,1065	No										
1065	Pintu Besi	25 days	Sat 9/8/18	Wed 10/3/18	1061	No										
1066	Pengecatan	25 days	Sun 10/28/18	Thu 11/22/18	1054,1060,1061,1063	No										
1067	Finish Lantai 15	1 day	Mon 1/21/19	Mon 1/21/19	1016,1042,1049,1066	Yes										

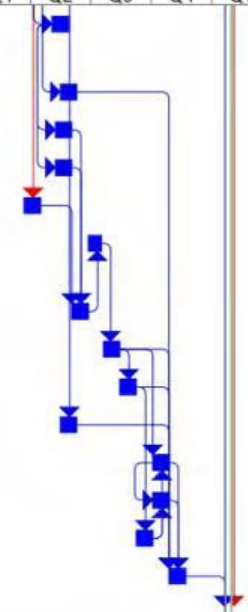

Lampiran 17. Daftar Aktivitas, *Network Planning, Predecessor* Lantai 16

PEMILIK		COMPOSITE SCHEDULE					KONSULTAN MK												
PODO MORO CITY		FINISHING-ME TOWER 3L					JAYA CM												
ID	Task Name	Duration	Start	Finish	Predecessors	Critical	2017	Q1	Q2	Q3	Q4	2018	Q1	Q2	Q3	Q4	2019	Q1	Q2
1	SCHEDULE FINISHING-ME TOWER 3L	391 days	Mon 1/1/18	Sat 1/26/19		Yes													
2	LINCOLN (Lantai LM)	391 days	Mon 1/1/18	Sat 1/26/19		Yes													
3	LANTAI 1	321 days	Mon 1/1/18	Sat 11/17/18		No													
74	LANTAI 2	321 days	Sat 1/6/18	Thu 11/22/18	35S+5 days	No													
145	LANTAI 3	321 days	Thu 1/11/18	Tue 11/27/18	74SS+5 days	No													
216	LANTAI 5	321 days	Tue 1/16/18	Sun 12/2/18	145SS+5 days	No													
287	LANTAI 6	321 days	Sun 1/21/18	Fri 12/7/18	216SS+5 days	No													
358	LANTAI 7	321 days	Fri 1/26/18	Wed 12/12/18	287SS+5 days	No													
429	LANTAI 8	321 days	Wed 1/31/18	Mon 12/17/18	358SS+5 days	No													
500	LANTAI 9	321 days	Mon 2/5/18	Sat 12/22/18	429SS+5 days	No													
571	LANTAI 10	321 days	Sat 2/10/18	Thu 12/27/18	500SS+5 days	No													
642	LANTAI 11	321 days	Thu 2/15/18	Tue 1/1/19	571SS+5 days	No													
713	LANTAI 11	321 days	Thu 2/15/18	Tue 1/1/19	571SS+5 days	No													
784	LANTAI 12	321 days	Tue 2/20/18	Sun 1/6/19	713SS+5 days	No													
855	LANTAI 13	321 days	Sun 2/25/18	Fri 1/11/19	784SS+5 days	No													
926	LANTAI 14	321 days	Fri 3/2/18	Wed 1/16/19	855SS+5 days	No													
997	LANTAI 15	321 days	Wed 3/7/18	Mon 1/21/19	926SS+5 days	No													
1068	LANTAI 16	321 days	Mon 3/12/18	Sat 1/26/19	997SS+5 days	Yes													
1069	AREA UNIT	285 days	Mon 3/12/18	Fri 12/21/18		Yes													
1070	MARKING	15 days	Mon 3/12/18	Mon 3/26/18		Yes													
1071	PEKERJAAN DINDING	270 days	Tue 3/27/18	Fri 12/21/18		Yes													
1072	PASANG BATA	30 days	Tue 3/27/18	Wed 4/25/18	1070	Yes													
1073	PLESTER/RENDER	30 days	Sat 5/26/18	Sun 6/24/18	1072,1076,1077,10	No													
1074	CAT DINDING	30 days	Mon 6/25/18	Tue 7/24/18	1073	No													
1075	MEP DINDING	240 days	Thu 4/26/18	Fri 12/21/18		No													
1076	ELEKTRONIK	30 days	Thu 4/26/18	Fri 5/25/18	1072	No													

ID	Task Name	Duration	Start	Finish	Predecessors	Critical	2017		2018				2019			
							Q1	Q2	Q3	Q4	Q1	Q2	Q3	Q4	Q1	Q2
1077	ELEKTRIKAL	30 days	Thu 4/26/18	Fri 5/25/18	1072	No										
1078	MVAC	30 days	Thu 4/26/18	Fri 5/25/18	1072	No										
1079	FIXTURES MEP DALAM DINDING	30 days	Thu 11/22/18	Fri 12/21/18	1076,1077,1078,10	No										
1080	TEST MEP	30 days	Sat 5/26/18	Sun 6/24/18	1076,1077,1078	No										
1081	PINTU KAYU	60 days	Sun 9/23/18	Wed 11/21/18		No										
1082	KUSEN PINTU	30 days	Sun 9/23/18	Mon 10/22/18	1073,1086	No										
1083	DAUN PINTU	30 days	Sun 9/23/18	Mon 10/22/18	1074FF,1082SS	No										
1084	ACESSORIES	30 days	Tue 10/23/18	Wed 11/21/18	1083	No										
1085	PEKERJAAN LANTAI	44 days	Fri 8/24/18	Sat 10/6/18		No										
1086	PASANG MARBEL	30 days	Fri 8/24/18	Sat 9/22/18	1090	No										
1087	POLES MARBEL	30 days	Fri 9/7/18	Sat 10/6/18	1086SS+14 days	No										
1088	PEKERJAAN PLAFOND	240 days	Thu 4/26/18	Fri 12/21/18		No										
1089	PASANG RANGKA	30 days	Mon 6/25/18	Tue 7/24/18	1073,1094,1097	No										
1090	TUTUP PLAFOND	30 days	Wed 7/25/18	Thu 8/23/18	1089,1099	No										
1091	COMPOUND	30 days	Fri 8/24/18	Sat 9/22/18	1090	No										
1092	CAT PLAFOND	30 days	Sun 9/23/18	Mon 10/22/18	1091	No										
1093	MEP DALAM PLAFOND	240 days	Thu 4/26/18	Fri 12/21/18		No										
1094	ELEKTRIKAL	30 days	Thu 4/26/18	Fri 5/25/18	1072,1077SS	No										
1095	ELEKTRONIK	30 days	Thu 4/26/18	Fri 5/25/18	1072,1076SS	No										
1096	MVAC	30 days	Thu 4/26/18	Fri 5/25/18	1072,1078SS	No										
1097	PLPK	30 days	Thu 4/26/18	Fri 5/25/18	1072	No										
1098	FIXTURE MEP DALAM PLAFOND	30 days	Thu 11/22/18	Fri 12/21/18	1084,1090,1094,10	No										
1099	TEST MEP	30 days	Sat 5/26/18	Sun 6/24/18	1094,1095,1096,10	No										
1100	AREA KAMAR MANDI	275 days	Thu 4/26/18	Fri 1/25/19		Yes										

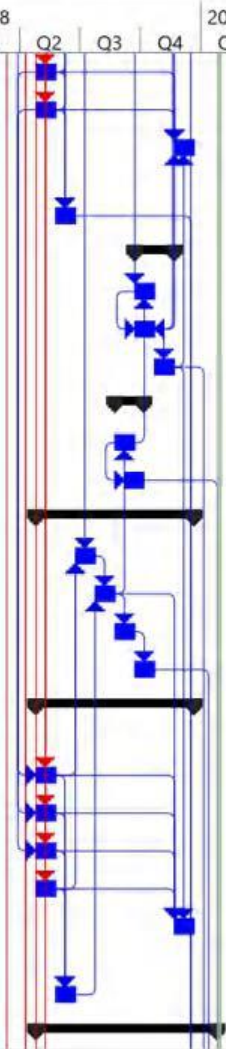

ID	Task Name	Duration	Start	Finish	Predecessors	Critical	2017				2018				2019	
							Q1	Q2	Q3	Q4	Q1	Q2	Q3	Q4	Q1	Q2
1101	CORING	20 days	Thu 4/26/18	Tue 5/15/18	1072	Yes										
1102	PASANG PIPA	25 days	Wed 5/16/18	Sat 6/9/18	1101	Yes										
1103	TEST BOCOR	20 days	Sun 6/10/18	Fri 6/29/18	1102	Yes										
1104	GROUTING	25 days	Sat 6/30/18	Tue 7/24/18	1103	Yes										
1105	PASANG HT DINDING	25 days	Sat 9/8/18	Tue 10/2/18	1072SS,1103,1107	Yes										
1106	WATER PROOFING	25 days	Wed 7/25/18	Sat 8/18/18	1104	Yes										
1107	TEST WATER PROOFING	20 days	Sun 8/19/18	Fri 9/7/18	1106	Yes										
1108	PASANG HT LANTAI	25 days	Thu 11/22/18	Sun 12/16/18	1105,1107,1110	Yes										
1109	PASANG RANGKA PLAFOND	25 days	Wed 10/3/18	Sat 10/27/18	1105	Yes										
1110	TUTUP PLAFOND	25 days	Sun 10/28/18	Wed 11/21/18	1109	Yes										
1111	CAT PLAFOND	25 days	Thu 11/22/18	Sun 12/16/18	1092FF,1110	No										
1112	PASANG PINTU	20 days	Mon 12/17/18	Sat 1/5/19	1073,1080,1108	Yes										
1113	PASANG SANITARY	20 days	Sun 1/6/19	Fri 1/25/19	1084,1112	Yes										
1114	AREA FAÇADE/BALKON	125 days	Tue 3/27/18	Sun 7/29/18		No										
1115	PASANG PC PANEL	25 days	Tue 3/27/18	Fri 4/20/18	1070	No										
1116	PASANG JENDELA ALUMINIUM	25 days	Sat 4/21/18	Tue 5/15/18	1115	No										
1117	PASANG RAILING BALKON	30 days	Sat 4/21/18	Sun 5/20/18	1115	No										
1118	PASANG HT LANTAI	25 days	Thu 7/5/18	Sun 7/29/18	1120	No										
1119	WATER PROOFING	25 days	Mon 5/21/18	Thu 6/14/18	1117	No										
1120	TEST WATER PROOFING	20 days	Fri 6/15/18	Wed 7/4/18	1119	No										
1121	AREA CORIDOR	245.5 days	Tue 3/27/18	Tue 11/27/18		No										
1122	Pasang Bata	25 days	Thu 4/26/18	Sun 5/20/18	1070FS+30 days	No										
1123	Pasang Conduit + Inbodur di Dinding	25 days	Tue 5/8/18	Sat 6/2/18	1122SS+50%	No										

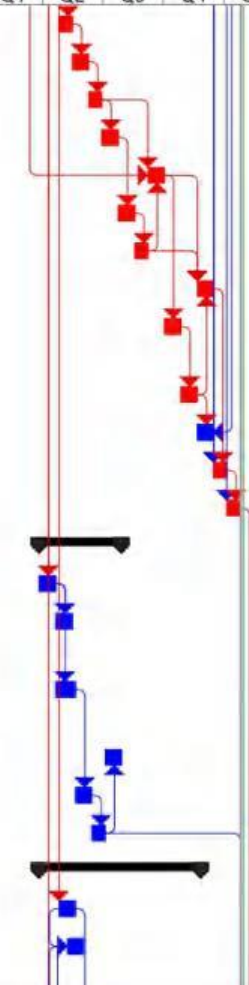

ID	Task Name	Duration	Start	Finish	Predecessors	Critical	2017		2018				2019				
							Q1	Q2	Q3	Q4	Q1	Q2	Q3	Q4	Q1	Q2	
1124	Pasang Conduit di Plafond	25 days	Tue 5/8/18	Sat 6/2/18	1123SS	No											
1125	Render/Plaster	25 days	Mon 5/21/18	Thu 6/14/18	1123SS+50%	No											
1126	Instalasi Kabel	25 days	Sun 5/13/18	Thu 6/7/18	1124SS+5 days	No											
1127	Instalasi MVAC	25 days	Sun 5/13/18	Thu 6/7/18	1124SS+5 days	No											
1128	Pipa Fire Fighting	25 days	Tue 3/27/18	Fri 4/20/18	1070	No											
1129	Test Parsial MEP dalam Plafond	20 days	Mon 7/2/18	Sun 7/22/18	1130	No											
1130	Rangka Plafond	25 days	Thu 6/7/18	Mon 7/2/18	1126,1127,1128	No											
1131	Tutup Plafond	25 days	Wed 7/25/18	Sun 8/19/18	1129FS+3 days	No											
1132	Pasang HT/Keramik	25 days	Sun 8/19/18	Thu 9/13/18	1131	No											
1133	Railing Tangga	25 days	Mon 5/21/18	Thu 6/14/18	1122	No											
1134	ME Fixture di Plafond	25 days	Mon 10/8/18	Fri 11/2/18	1131,1136	No											
1135	ME Fixture di Dinding	25 days	Mon 10/8/18	Fri 11/2/18	1134SS,1136	No											
1136	Pintu Besi	25 days	Thu 9/13/18	Mon 10/8/18	1132	No											
1137	Pengecatan	25 days	Fri 11/2/18	Tue 11/27/18	1125,1131,1132,1133	No											
1138	Finish Lantai 16	1 day	Sat 1/26/19	Sat 1/26/19	1087,1113,1120,1137	Yes											

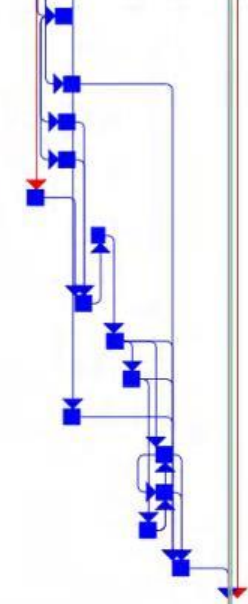

Lampiran 18. Daftar Aktivitas, *Network Planning, Predecessor* Lantai 17

PEMILIK		COMPOSITE SCHEDULE					KONSULTAN MK									
PODO MORO CITY DELI MEGAH		FINISHING-ME TOWER 3L					JAYA CM									
ID	Task Name	Duration	Start	Finish	Predecessors	Critical	2017				2018				2019	
							Q1	Q2	Q3	Q4	Q1	Q2	Q3	Q4	Q1	Q2
1	SCHEDULE FINISHING-ME TOWER 3L	396 days	Mon 1/1/18	Thu 1/31/19		Yes										
2	LINCOLN (Lantai LM)	396 days	Mon 1/1/18	Thu 1/31/19		Yes										
3	LANTAI 1	321 days	Mon 1/1/18	Sat 11/17/18		No										
74	LANTAI 2	321 days	Sat 1/6/18	Thu 11/22/18	35S+5 days	No										
145	LANTAI 3	321 days	Thu 1/11/18	Tue 11/27/18	74SS+5 days	No										
216	LANTAI 5	321 days	Tue 1/16/18	Sun 12/2/18	145SS+5 days	No										
287	LANTAI 6	321 days	Sun 1/21/18	Fri 12/7/18	216SS+5 days	No										
358	LANTAI 7	321 days	Fri 1/26/18	Wed 12/12/18	287SS+5 days	No										
429	LANTAI 8	321 days	Wed 1/31/18	Mon 12/17/18	358SS+5 days	No										
500	LANTAI 9	321 days	Mon 2/5/18	Sat 12/22/18	429SS+5 days	No										
571	LANTAI 10	321 days	Sat 2/10/18	Thu 12/27/18	500SS+5 days	No										
642	LANTAI 11	321 days	Thu 2/15/18	Tue 1/1/19	571SS+5 days	No										
713	LANTAI 11	321 days	Thu 2/15/18	Tue 1/1/19	571SS+5 days	No										
784	LANTAI 12	321 days	Tue 2/20/18	Sun 1/6/19	713SS+5 days	No										
855	LANTAI 13	321 days	Sun 2/25/18	Fri 1/11/19	784SS+5 days	No										
926	LANTAI 14	321 days	Fri 3/2/18	Wed 1/16/19	855SS+5 days	No										
997	LANTAI 15	321 days	Wed 3/7/18	Mon 1/21/19	926SS+5 days	No										
1068	LANTAI 16	321 days	Mon 3/12/18	Sat 1/26/19	997SS+5 days	No										
1139	LANTAI 17	321 days	Sat 3/17/18	Thu 1/31/19	1068SS+5 days	Yes										
1140	AREA UNIT	285 days	Sat 3/17/18	Wed 12/26/18		Yes										
1141	MARKING	15 days	Sat 3/17/18	Sat 3/31/18		Yes										
1142	PEKERJAAN DINDING	270 days	Sun 4/1/18	Wed 12/26/18		Yes										
1143	PASANG BATA	30 days	Sun 4/1/18	Mon 4/30/18	1141	Yes										
1144	PLESTER/RENDER	30 days	Thu 5/31/18	Fri 6/29/18	1143,1147,1148,1149	No										
1145	CAT DINDING	30 days	Sat 6/30/18	Sun 7/29/18	1144	No										
1146	MEP DINDING	240 days	Tue 5/1/18	Wed 12/26/18		No										

ID	Task Name	Duration	Start	Finish	Predecessors	Critical	2017		2018				2019			
							Q1	Q2	Q3	Q4	Q1	Q2	Q3	Q4	Q1	Q2
1147	ELEKTRONIK	30 days	Tue 5/1/18	Wed 5/30/18	1143	No										
1148	ELEKTRIKAL	30 days	Tue 5/1/18	Wed 5/30/18	1143	No										
1149	MVAC	30 days	Tue 5/1/18	Wed 5/30/18	1143	No										
1150	FIXTURES MEP DALAM DINDING	30 days	Tue 11/27/18	Wed 12/26/18	1147,1148,1149,1151	No										
1151	TEST MEP	30 days	Thu 5/31/18	Fri 6/29/18	1147,1148,1149	No										
1152	PINTU KAYU	60 days	Fri 9/28/18	Mon 11/26/18		No										
1153	KUSEN PINTU	30 days	Fri 9/28/18	Sat 10/27/18	1144,1157	No										
1154	DAUN PINTU	30 days	Fri 9/28/18	Sat 10/27/18	1145FF,1153SS	No										
1155	ACESSORIES	30 days	Sun 10/28/18	Mon 11/26/18	1154	No										
1156	PEKERJAAN LANTAI	44 days	Wed 8/29/18	Thu 10/11/18		No										
1157	PASANG MARBEL	30 days	Wed 8/29/18	Thu 9/27/18	1161	No										
1158	POLES MARBEL	30 days	Wed 9/12/18	Thu 10/11/18	1157SS+14 days	No										
1159	PEKERJAAN PLAFOND	240 days	Tue 5/1/18	Wed 12/26/18		No										
1160	PASANG RANGKA	30 days	Sat 6/30/18	Sun 7/29/18	1144,1165,1168	No										
1161	TUTUP PLAFOND	30 days	Mon 7/30/18	Tue 8/28/18	1160,1170	No										
1162	COMPOUND	30 days	Wed 8/29/18	Thu 9/27/18	1161	No										
1163	CAT PLAFOND	30 days	Fri 9/28/18	Sat 10/27/18	1162	No										
1164	MEP DALAM PLAFOND	240 days	Tue 5/1/18	Wed 12/26/18		No										
1165	ELEKTRIKAL	30 days	Tue 5/1/18	Wed 5/30/18	1143,1148SS	No										
1166	ELEKTRONIK	30 days	Tue 5/1/18	Wed 5/30/18	1143,1147SS	No										
1167	MVAC	30 days	Tue 5/1/18	Wed 5/30/18	1143,1149SS	No										
1168	PLPK	30 days	Tue 5/1/18	Wed 5/30/18	1143	No										
1169	FIXTURE MEP DALAM PLAFOND	30 days	Tue 11/27/18	Wed 12/26/18	1155,1161,1165,1169	No										
1170	TEST MEP	30 days	Thu 5/31/18	Fri 6/29/18	1165,1166,1167,1169	No										

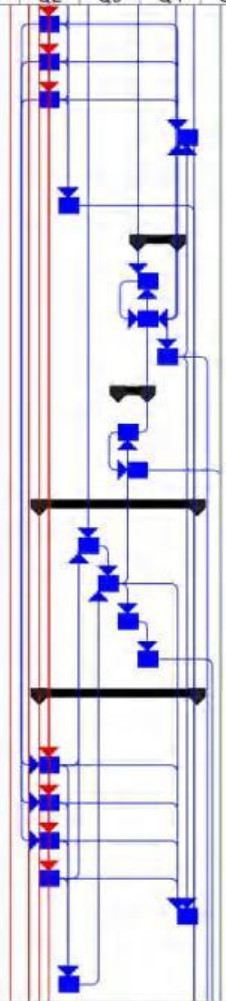

ID	Task Name	Duration	Start	Finish	Predecessors	Critical	2017		2018				2019				
							Q1	Q2	Q3	Q4	Q1	Q2	Q3	Q4	Q1	Q2	
1171	AREA KAMAR MANDI	275 days	Tue 5/1/18	Wed 1/30/19		Yes											
1172	CORING	20 days	Tue 5/1/18	Sun 5/20/18	1143	Yes											
1173	PASANG PIPA	25 days	Mon 5/21/18	Thu 6/14/18	1172	Yes											
1174	TEST BOCOR	20 days	Fri 6/15/18	Wed 7/4/18	1173	Yes											
1175	GROUTING	25 days	Thu 7/5/18	Sun 7/29/18	1174	Yes											
1176	PASANG HT DINDING	25 days	Thu 9/13/18	Sun 10/7/18	1143SS,1174,1178	Yes											
1177	WATER PROOFING	25 days	Mon 7/30/18	Thu 8/23/18	1175	Yes											
1178	TEST WATER PROOFING	20 days	Fri 8/24/18	Wed 9/12/18	1177	Yes											
1179	PASANG HT LANTAI	25 days	Tue 11/27/18	Fri 12/21/18	1176,1178,1181	Yes											
1180	PASANG RANGKA PLAFOND	25 days	Mon 10/8/18	Thu 11/1/18	1176	Yes											
1181	TUTUP PLAFOND	25 days	Fri 11/2/18	Mon 11/26/18	1180	Yes											
1182	CAT PLAFOND	25 days	Tue 11/27/18	Fri 12/21/18	1163FF,1181	No											
1183	PASANG PINTU	20 days	Sat 12/22/18	Thu 1/10/19	1144,1151,1179	Yes											
1184	PASANG SANITARY	20 days	Fri 1/11/19	Wed 1/30/19	1155,1183	Yes											
1185	AREA FAÇADE/BALKON	125 days	Sun 4/1/18	Fri 8/3/18		No											
1186	PASANG PC PANEL	25 days	Sun 4/1/18	Wed 4/25/18	1141	No											
1187	PASANG JENDELA ALUMINIUM	25 days	Thu 4/26/18	Sun 5/20/18	1186	No											
1188	PASANG RAILING BALKON	30 days	Thu 4/26/18	Fri 5/25/18	1186	No											
1189	PASANG HT LANTAI	25 days	Tue 7/10/18	Fri 8/3/18	1191	No											
1190	WATER PROOFING	25 days	Sat 5/26/18	Tue 6/19/18	1188	No											
1191	TEST WATER PROOFING	20 days	Wed 6/20/18	Mon 7/9/18	1190	No											
1192	AREA CORIDOR	245.5 days	Sun 4/1/18	Sun 12/2/18		No											
1193	Pasang Bata	25 days	Tue 5/1/18	Fri 5/25/18	1141FS+30 days	No											

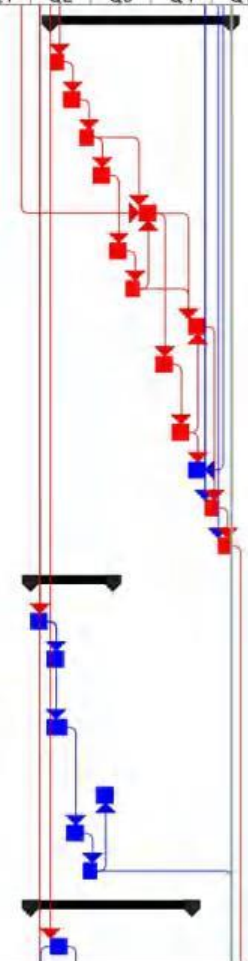

ID	Task Name	Duration	Start	Finish	Predecessors	Critical	2017		2018				2019			
							Q1	Q2	Q3	Q4	Q1	Q2	Q3	Q4	Q1	Q2
1194	Pasang Conduit + Inbodur di Dinding	25 days	Sun 5/13/18	Thu 6/7/18	1193SS+50%	No										
1195	Pasang Conduit di Plafond	25 days	Sun 5/13/18	Thu 6/7/18	1194SS	No										
1196	Render/Plaster	25 days	Sat 5/26/18	Tue 6/19/18	1194SS+50%	No										
1197	Instalasi Kabel	25 days	Fri 5/18/18	Tue 6/12/18	1195SS+5 days	No										
1198	Instalasi MVAC	25 days	Fri 5/18/18	Tue 6/12/18	1195SS+5 days	No										
1199	Pipa Fire Fighting	25 days	Sun 4/1/18	Wed 4/25/18	1141	No										
1200	Test Parsial MEP dalam Plafond	20 days	Sat 7/7/18	Fri 7/27/18	1201	No										
1201	Rangka Plafond	25 days	Tue 6/12/18	Sat 7/7/18	1197,1198,1199	No										
1202	Tutup Plafond	25 days	Mon 7/30/18	Fri 8/24/18	1200FS+3 days	No										
1203	Pasang HT/Keramik	25 days	Fri 8/24/18	Tue 9/18/18	1202	No										
1204	Railing Tangga	25 days	Sat 5/26/18	Tue 6/19/18	1193	No										
1205	ME Fixture di Plafond	25 days	Sat 10/13/18	Wed 11/7/18	1202,1207	No										
1206	ME Fixture di Dinding	25 days	Sat 10/13/18	Wed 11/7/18	1205SS,1207	No										
1207	Pintu Besi	25 days	Tue 9/18/18	Sat 10/13/18	1203	No										
1208	Pengecatan	25 days	Wed 11/7/18	Sun 12/2/18	1196,1202,1203,1206	No										
1209	Finish Lantai 17	1 day	Thu 1/31/19	Thu 1/31/19	1158,1184,1191,1208	Yes										

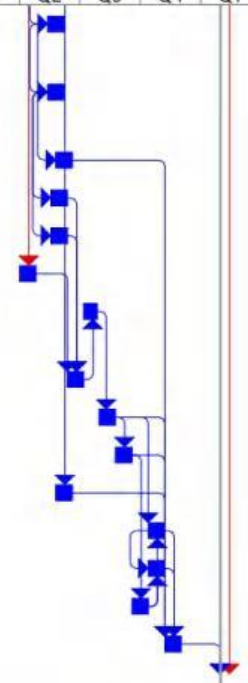

Lampiran 19. Daftar Aktivitas, *Network Planning, Predecessor* Lantai 18

PEMILIK		COMPOSITE SCHEDULE					KONSULTAN MK									
PODO MORO CITY DELI MEGAN		FINISHING-ME TOWER 3L					JAYA CM									
ID	Task Name	Duration	Start	Finish	Predecessors	Critical	2017				2018				2019	
							Q1	Q2	Q3	Q4	Q1	Q2	Q3	Q4	Q1	Q2
1	SCHEDULE FINISHING-ME TOWER 3L	401 days	Mon 1/1/18	Tue 2/5/19		Yes										
2	LINCOLN (Lantai LM)	401 days	Mon 1/1/18	Tue 2/5/19		Yes										
3	LANTAI 1	321 days	Mon 1/1/18	Sat 11/17/18		No										
74	LANTAI 2	321 days	Sat 1/6/18	Thu 11/22/18	3SS+5 days	No										
145	LANTAI 3	321 days	Thu 1/11/18	Tue 11/27/18	74SS+5 days	No										
216	LANTAI 5	321 days	Tue 1/16/18	Sun 12/2/18	145SS+5 days	No										
287	LANTAI 6	321 days	Sun 1/21/18	Fri 12/7/18	216SS+5 days	No										
358	LANTAI 7	321 days	Fri 1/26/18	Wed 12/12/18	287SS+5 days	No										
429	LANTAI 8	321 days	Wed 1/31/18	Mon 12/17/18	358SS+5 days	No										
500	LANTAI 9	321 days	Mon 2/5/18	Sat 12/22/18	429SS+5 days	No										
571	LANTAI 10	321 days	Sat 2/10/18	Thu 12/27/18	500SS+5 days	No										
642	LANTAI 11	321 days	Thu 2/15/18	Tue 1/1/19	571SS+5 days	No										
713	LANTAI 11	321 days	Thu 2/15/18	Tue 1/1/19	571SS+5 days	No										
784	LANTAI 12	321 days	Tue 2/20/18	Sun 1/6/19	713SS+5 days	No										
855	LANTAI 13	321 days	Sun 2/25/18	Fri 1/11/19	784SS+5 days	No										
926	LANTAI 14	321 days	Fri 3/2/18	Wed 1/16/19	855SS+5 days	No										
997	LANTAI 15	321 days	Wed 3/7/18	Mon 1/21/19	926SS+5 days	No										
1068	LANTAI 16	321 days	Mon 3/12/18	Sat 1/26/19	997SS+5 days	No										
1139	LANTAI 17	321 days	Sat 3/17/18	Thu 1/31/19	1068SS+5 days	No										
1210	LANTAI 18	321 days	Thu 3/22/18	Tue 2/5/19	1139SS+5 days	Yes										
1211	AREA UNIT	285 days	Thu 3/22/18	Mon 12/31/18		Yes										
1212	MARKING	15 days	Thu 3/22/18	Thu 4/5/18		Yes										
1213	PEKERJAAN DINDING	270 days	Fri 4/6/18	Mon 12/31/18		Yes										
1214	PASANG BATA	30 days	Fri 4/6/18	Sat 5/5/18	1212	Yes										
1215	PLESTER/RENDER	30 days	Tue 6/5/18	Wed 7/4/18	1214,1218,1219,12	No										
1216	CAT DINDING	30 days	Thu 7/5/18	Fri 8/3/18	1215	No										

ID	Task Name	Duration	Start	Finish	Predecessors	Critical	2017		2018				2019				
							Q1	Q2	Q3	Q4	Q1	Q2	Q3	Q4	Q1	Q2	
1217	MEP DINDING	240 days	Sun 5/6/18	Mon 12/31/18		No											
1218	ELEKTRONIK	30 days	Sun 5/6/18	Mon 6/4/18	1214	No											
1219	ELEKTRIKAL	30 days	Sun 5/6/18	Mon 6/4/18	1214	No											
1220	MVAC	30 days	Sun 5/6/18	Mon 6/4/18	1214	No											
1221	FIXTURES MEP DALAM DINDING	30 days	Sun 12/2/18	Mon 12/31/18	1218,1219,1220,1222	No											
1222	TEST MEP	30 days	Tue 6/5/18	Wed 7/4/18	1218,1219,1220	No											
1223	PINTU KAYU	60 days	Wed 10/3/18	Sat 12/1/18		No											
1224	KUSEN PINTU	30 days	Wed 10/3/18	Thu 11/1/18	1215,1228	No											
1225	DAUN PINTU	30 days	Wed 10/3/18	Thu 11/1/18	1216FF,1224SS	No											
1226	ACESSORIES	30 days	Fri 11/2/18	Sat 12/1/18	1225	No											
1227	PEKERJAAN LANTAI	44 days	Mon 9/3/18	Tue 10/16/18		No											
1228	PASANG MARBEL	30 days	Mon 9/3/18	Tue 10/2/18	1232	No											
1229	POLES MARBEL	30 days	Mon 9/17/18	Tue 10/16/18	1228SS+14 days	No											
1230	PEKERJAAN PLAFOND	240 days	Sun 5/6/18	Mon 12/31/18		No											
1231	PASANG RANGKA	30 days	Thu 7/5/18	Fri 8/3/18	1215,1236,1239	No											
1232	TUTUP PLAFOND	30 days	Sat 8/4/18	Sun 9/2/18	1231,1241	No											
1233	COMPOUND	30 days	Mon 9/3/18	Tue 10/2/18	1232	No											
1234	CAT PLAFOND	30 days	Wed 10/3/18	Thu 11/1/18	1233	No											
1235	MEP DALAM PLAFOND	240 days	Sun 5/6/18	Mon 12/31/18		No											
1236	ELEKTRIKAL	30 days	Sun 5/6/18	Mon 6/4/18	1214,1219SS	No											
1237	ELEKTRONIK	30 days	Sun 5/6/18	Mon 6/4/18	1214,1218SS	No											
1238	MVAC	30 days	Sun 5/6/18	Mon 6/4/18	1214,1220SS	No											
1239	PLPK	30 days	Sun 5/6/18	Mon 6/4/18	1214	No											
1240	FIXTURE MEP DALAM PLAFOND	30 days	Sun 12/2/18	Mon 12/31/18	1226,1232,1236,1239	No											

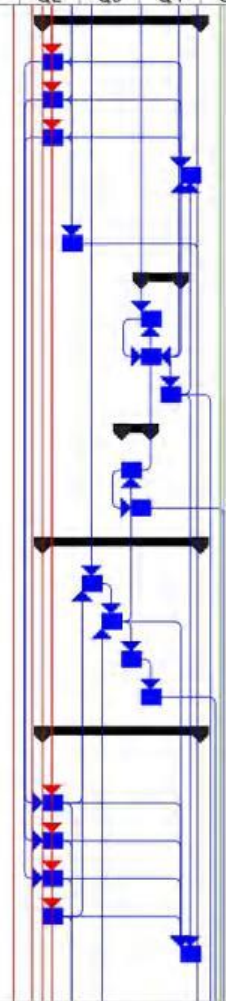

ID	Task Name	Duration	Start	Finish	Predecessors	Critical	2017		2018				2019				
							Q1	Q2	Q3	Q4	Q1	Q2	Q3	Q4	Q1	Q2	
1241	TEST MEP	30 days	Tue 6/5/18	Wed 7/4/18	1236,1237,1238,12	No											
1242	AREA KAMAR MANDI	275 days	Sun 5/6/18	Mon 2/4/19		Yes											
1243	CORING	20 days	Sun 5/6/18	Fri 5/25/18	1214	Yes											
1244	PASANG PIPA	25 days	Sat 5/26/18	Tue 6/19/18	1243	Yes											
1245	TEST BOCOR	20 days	Wed 6/20/18	Mon 7/9/18	1244	Yes											
1246	GROUTING	25 days	Tue 7/10/18	Fri 8/3/18	1245	Yes											
1247	PASANG HT DINDING	25 days	Tue 9/18/18	Fri 10/12/18	1214SS,1245,1249	Yes											
1248	WATER PROOFING	25 days	Sat 8/4/18	Tue 8/28/18	1246	Yes											
1249	TEST WATER PROOFING	20 days	Wed 8/29/18	Mon 9/17/18	1248	Yes											
1250	PASANG HT LANTAI	25 days	Sun 12/2/18	Wed 12/26/18	1247,1249,1252	Yes											
1251	PASANG RANGKA PLAFOND	25 days	Sat 10/13/18	Tue 11/6/18	1247	Yes											
1252	TUTUP PLAFOND	25 days	Wed 11/7/18	Sat 12/1/18	1251	Yes											
1253	CAT PLAFOND	25 days	Sun 12/2/18	Wed 12/26/18	1234FF,1252	No											
1254	PASANG PINTU	20 days	Thu 12/27/18	Tue 1/15/19	1215,1222,1250	Yes											
1255	PASANG SANITARY	20 days	Wed 1/16/19	Mon 2/4/19	1226,1254	Yes											
1256	AREA FAÇADE/BALKON	125 days	Fri 4/6/18	Wed 8/8/18		No											
1257	PASANG PC PANEL	25 days	Fri 4/6/18	Mon 4/30/18	1212	No											
1258	PASANG JENDELA ALUMINIUM	25 days	Tue 5/1/18	Fri 5/25/18	1257	No											
1259	PASANG RAILING BALKON	30 days	Tue 5/1/18	Wed 5/30/18	1257	No											
1260	PASANG HT LANTAI	25 days	Sun 7/15/18	Wed 8/8/18	1262	No											
1261	WATER PROOFING	25 days	Thu 5/31/18	Sun 6/24/18	1259	No											
1262	TEST WATER PROOFING	20 days	Mon 6/25/18	Sat 7/14/18	1261	No											
1263	AREA CORIDOR	245.5 days	Fri 4/6/18	Fri 12/7/18		No											
1264	Pasang Bata	25 days	Sun 5/6/18	Wed 5/30/18	1212FS+30 days	No											

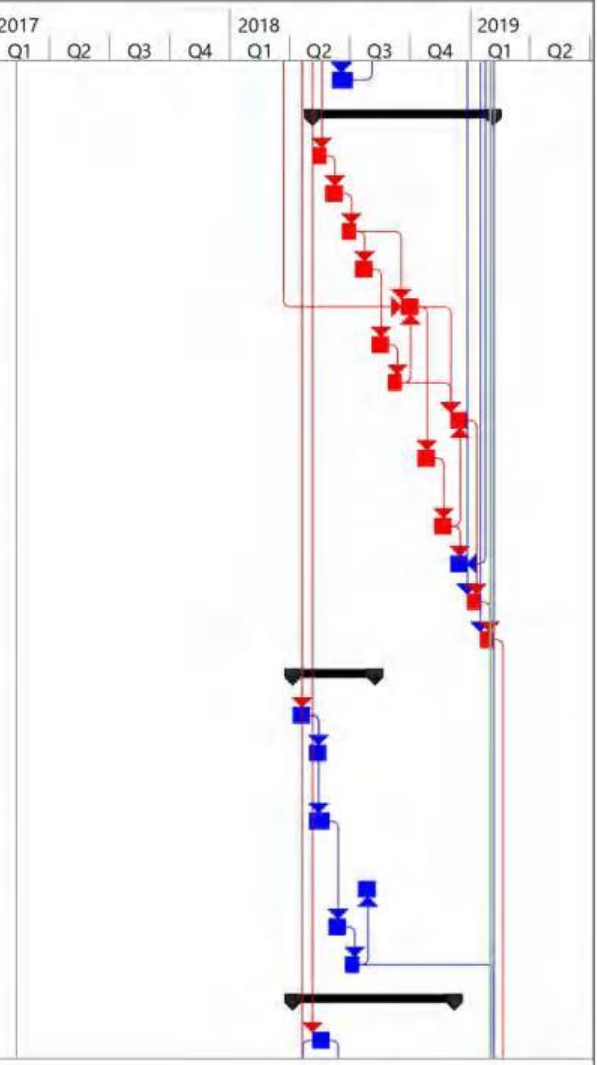

ID	Task Name	Duration	Start	Finish	Predecessors	Critical	2017		2018				2019			
							Q1	Q2	Q3	Q4	Q1	Q2	Q3	Q4	Q1	Q2
1265	Pasang Conduit + Inbodus di Dinding	25 days	Fri 5/18/18	Tue 6/12/18	1264SS+50%	No										
1266	Pasang Conduit di Plafond	25 days	Fri 5/18/18	Tue 6/12/18	1265SS	No										
1267	Render/Plaster	25 days	Thu 5/31/18	Sun 6/24/18	1265SS+50%	No										
1268	Instalasi Kabel	25 days	Wed 5/23/18	Sun 6/17/18	1266SS+5 days	No										
1269	Instalasi MVAC	25 days	Wed 5/23/18	Sun 6/17/18	1266SS+5 days	No										
1270	Pipa Fire Fighting	25 days	Fri 4/6/18	Mon 4/30/18	1212	No										
1271	Test Parsial MEP dalam Plafond	20 days	Thu 7/12/18	Wed 8/1/18	1272	No										
1272	Rangka Plafond	25 days	Sun 6/17/18	Thu 7/12/18	1268,1269,1270	No										
1273	Tutup Plafond	25 days	Sat 8/4/18	Wed 8/29/18	1271FS+3 days	No										
1274	Pasang HT/Keramik	25 days	Wed 8/29/18	Sun 9/23/18	1273	No										
1275	Railing Tangga	25 days	Thu 5/31/18	Sun 6/24/18	1264	No										
1276	ME Fixture di Plafond	25 days	Thu 10/18/18	Mon 11/12/18	1273,1278	No										
1277	ME Fixture di Dinding	25 days	Thu 10/18/18	Mon 11/12/18	1276SS,1278	No										
1278	Pintu Besi	25 days	Sun 9/23/18	Thu 10/18/18	1274	No										
1279	Pengecatan	25 days	Mon 11/12/18	Fri 12/7/18	1267,1273,1274,1277	No										
1280	Finish Lantai 18	1 day	Tue 2/5/19	Tue 2/5/19	1229,1255,1262,1279	Yes										

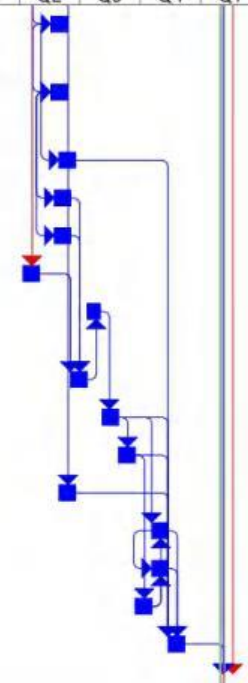

Lampiran 20. Daftar Aktivitas, *Network Planning, Predecessor* Lantai 18A

PEMILIK		COMPOSITE SCHEDULE					KONSULTAN MK									
PODO MORO CITY DELI MEGAH		FINISHING-ME TOWER 3L					JAYA CM									
ID	Task Name	Duration	Start	Finish	Predecessors	Critical	2017				2018				2019	
							Q1	Q2	Q3	Q4	Q1	Q2	Q3	Q4	Q1	Q2
1	SCHEDULE FINISHING-ME TOWER 3L	406 days	Mon 1/1/18	Sun 2/10/19		Yes										
2	LINCOLN (Lantai LM)	406 days	Mon 1/1/18	Sun 2/10/19		Yes										
3	LANTAI 1	321 days	Mon 1/1/18	Sat 11/17/18		No										
74	LANTAI 2	321 days	Sat 1/6/18	Thu 11/22/18	35S+5 days	No										
145	LANTAI 3	321 days	Thu 1/11/18	Tue 11/27/18	74SS+5 days	No										
216	LANTAI 5	321 days	Tue 1/16/18	Sun 12/2/18	145SS+5 days	No										
287	LANTAI 6	321 days	Sun 1/21/18	Fri 12/7/18	216SS+5 days	No										
358	LANTAI 7	321 days	Fri 1/26/18	Wed 12/12/18	287SS+5 days	No										
429	LANTAI 8	321 days	Wed 1/31/18	Mon 12/17/18	358SS+5 days	No										
500	LANTAI 9	321 days	Mon 2/5/18	Sat 12/22/18	429SS+5 days	No										
571	LANTAI 10	321 days	Sat 2/10/18	Thu 12/27/18	500SS+5 days	No										
642	LANTAI 11	321 days	Thu 2/15/18	Tue 1/1/19	571SS+5 days	No										
713	LANTAI 11	321 days	Thu 2/15/18	Tue 1/1/19	571SS+5 days	No										
784	LANTAI 12	321 days	Tue 2/20/18	Sun 1/6/19	713SS+5 days	No										
855	LANTAI 13	321 days	Sun 2/25/18	Fri 1/11/19	784SS+5 days	No										
926	LANTAI 14	321 days	Fri 3/2/18	Wed 1/16/19	855SS+5 days	No										
997	LANTAI 15	321 days	Wed 3/7/18	Mon 1/21/19	926SS+5 days	No										
1068	LANTAI 16	321 days	Mon 3/12/18	Sat 1/26/19	997SS+5 days	No										
1139	LANTAI 17	321 days	Sat 3/17/18	Thu 1/31/19	1068SS+5 days	No										
1210	LANTAI 18	321 days	Thu 3/22/18	Tue 2/5/19	1139SS+5 days	No										
1281	LANTAI 18A	321 days	Tue 3/27/18	Sun 2/10/19	1210SS+5 days	Yes										
1282	AREA UNIT	285 days	Tue 3/27/18	Sat 1/5/19		Yes										
1283	MARKING	15 days	Tue 3/27/18	Tue 4/10/18		Yes										
1284	PEKERJAAN DINDING	270 days	Wed 4/11/18	Sat 1/5/19		Yes										
1285	PASANG BATA	30 days	Wed 4/11/18	Thu 5/10/18	1283	Yes										
1286	PLESTER/RENDER	30 days	Sun 6/10/18	Mon 7/9/18	1285,1289,1290,1291	No										

ID	Task Name	Duration	Start	Finish	Predecessors	Critical	2017		2018				2019				
							Q1	Q2	Q3	Q4	Q1	Q2	Q3	Q4	Q1	Q2	
1287	CAT DINDING	30 days	Tue 7/10/18	Wed 8/8/18	1286	No											
1288	MEP DINDING	240 days	Fri 5/11/18	Sat 1/5/19		No											
1289	ELEKTRONIK	30 days	Fri 5/11/18	Sat 6/9/18	1285	No											
1290	ELEKTRIKAL	30 days	Fri 5/11/18	Sat 6/9/18	1285	No											
1291	MVAC	30 days	Fri 5/11/18	Sat 6/9/18	1285	No											
1292	FIXTURES MEP DALAM DINDING	30 days	Fri 12/7/18	Sat 1/5/19	1289,1290,1291,1292	No											
1293	TEST MEP	30 days	Sun 6/10/18	Mon 7/9/18	1289,1290,1291	No											
1294	PINTU KAYU	60 days	Mon 10/8/18	Thu 12/6/18		No											
1295	KUSEN PINTU	30 days	Mon 10/8/18	Tue 11/6/18	1286,1299	No											
1296	DAUN PINTU	30 days	Mon 10/8/18	Tue 11/6/18	1287FF,1295SS	No											
1297	ACESSORIES	30 days	Wed 11/7/18	Thu 12/6/18	1296	No											
1298	PEKERJAAN LANTAI	44 days	Sat 9/8/18	Sun 10/21/18		No											
1299	PASANG MARBEL	30 days	Sat 9/8/18	Sun 10/7/18	1303	No											
1300	POLES MARBEL	30 days	Sat 9/22/18	Sun 10/21/18	1299SS+14 days	No											
1301	PEKERJAAN PLAFOND	240 days	Fri 5/11/18	Sat 1/5/19		No											
1302	PASANG RANGKA	30 days	Tue 7/10/18	Wed 8/8/18	1286,1307,1310	No											
1303	TUTUP PLAFOND	30 days	Thu 8/9/18	Fri 9/7/18	1302,1312	No											
1304	COMPOUND	30 days	Sat 9/8/18	Sun 10/7/18	1303	No											
1305	CAT PLAFOND	30 days	Mon 10/8/18	Tue 11/6/18	1304	No											
1306	MEP DALAM PLAFOND	240 days	Fri 5/11/18	Sat 1/5/19		No											
1307	ELEKTRIKAL	30 days	Fri 5/11/18	Sat 6/9/18	1285,1290SS	No											
1308	ELEKTRONIK	30 days	Fri 5/11/18	Sat 6/9/18	1285,1289SS	No											
1309	MVAC	30 days	Fri 5/11/18	Sat 6/9/18	1285,1291SS	No											
1310	PLPK	30 days	Fri 5/11/18	Sat 6/9/18	1285	No											

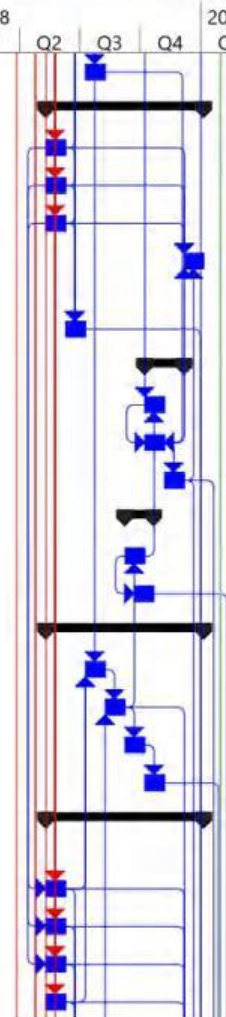

ID	Task Name	Duration	Start	Finish	Predecessors	Critical	2017		2018				2019			
							Q1	Q2	Q3	Q4	Q1	Q2	Q3	Q4	Q1	Q2
1311	FIXTURE MEP DALAM PLAFOND	30 days	Fri 12/7/18	Sat 1/5/19	1297,1303,1307,1310	No										
1312	TEST MEP	30 days	Sun 6/10/18	Mon 7/9/18	1307,1308,1309,1310	No										
1313	AREA KAMAR MANDI	275 days	Fri 5/11/18	Sat 2/9/19		Yes										
1314	CORING	20 days	Fri 5/11/18	Wed 5/30/18	1285	Yes										
1315	PASANG PIPA	25 days	Thu 5/31/18	Sun 6/24/18	1314	Yes										
1316	TEST BOCOR	20 days	Mon 6/25/18	Sat 7/14/18	1315	Yes										
1317	GROUTING	25 days	Sun 7/15/18	Wed 8/8/18	1316	Yes										
1318	PASANG HT DINDING	25 days	Sun 9/23/18	Wed 10/17/18	1285SS,1316,1320	Yes										
1319	WATER PROOFING	25 days	Thu 8/9/18	Sun 9/2/18	1317	Yes										
1320	TEST WATER PROOFING	20 days	Mon 9/3/18	Sat 9/22/18	1319	Yes										
1321	PASANG HT LANTAI	25 days	Fri 12/7/18	Mon 12/31/18	1318,1320,1323	Yes										
1322	PASANG RANGKA PLAFOND	25 days	Thu 10/18/18	Sun 11/11/18	1318	Yes										
1323	TUTUP PLAFOND	25 days	Mon 11/12/18	Thu 12/6/18	1322	Yes										
1324	CAT PLAFOND	25 days	Fri 12/7/18	Mon 12/31/18	1305FF,1323	No										
1325	PASANG PINTU	20 days	Tue 1/1/19	Sun 1/20/19	1286,1293,1321	Yes										
1326	PASANG SANITARY	20 days	Mon 1/21/19	Sat 2/9/19	1297,1325	Yes										
1327	AREA FAÇADE/BALKON	125 days	Wed 4/11/18	Mon 8/13/18		No										
1328	PASANG PC PANEL	25 days	Wed 4/11/18	Sat 5/5/18	1283	No										
1329	PASANG JENDELA ALUMINIUM	25 days	Sun 5/6/18	Wed 5/30/18	1328	No										
1330	PASANG RAILING BALKON	30 days	Sun 5/6/18	Mon 6/4/18	1328	No										
1331	PASANG HT LANTAI	25 days	Fri 7/20/18	Mon 8/13/18	1333	No										
1332	WATER PROOFING	25 days	Tue 6/5/18	Fri 6/29/18	1330	No										
1333	TEST WATER PROOFING	20 days	Sat 6/30/18	Thu 7/19/18	1332	No										

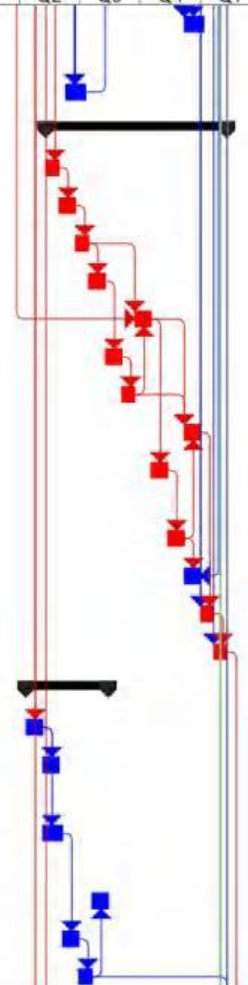

ID	Task Name	Duration	Start	Finish	Predecessors	Critical	2017		2018				2019			
							Q1	Q2	Q3	Q4	Q1	Q2	Q3	Q4	Q1	Q2
1334	AREA CORIDOR	245.5 days	Wed 4/11/18	Wed 12/12/18		No										
1335	Pasang Bata	25 days	Fri 5/11/18	Mon 6/4/18	1283FS+30 days	No										
1336	Pasang Conduit + Inbodus di Dinding	25 days	Wed 5/23/18	Sun 6/17/18	1335SS+50%	No										
1337	Pasang Conduit di Plafond	25 days	Wed 5/23/18	Sun 6/17/18	1336SS	No										
1338	Render/Plaster	25 days	Tue 6/5/18	Fri 6/29/18	1336SS+50%	No										
1339	Instalasi Kabel	25 days	Mon 5/28/18	Fri 6/22/18	1337SS+5 days	No										
1340	Instalasi MVAC	25 days	Mon 5/28/18	Fri 6/22/18	1337SS+5 days	No										
1341	Pipa Fire Fighting	25 days	Wed 4/11/18	Sat 5/5/18	1283	No										
1342	Test Parsial MEP dalam Plafond	20 days	Tue 7/17/18	Mon 8/6/18	1343	No										
1343	Rangka Plafond	25 days	Fri 6/22/18	Tue 7/17/18	1339,1340,1341	No										
1344	Tutup Plafond	25 days	Thu 8/9/18	Mon 9/3/18	1342FS+3 days	No										
1345	Pasang HT/Keramik	25 days	Mon 9/3/18	Fri 9/28/18	1344	No										
1346	Railing Tangga	25 days	Tue 6/5/18	Fri 6/29/18	1335	No										
1347	ME Fixture di Plafond	25 days	Tue 10/23/18	Sat 11/17/18	1344,1349	No										
1348	ME Fixture di Dinding	25 days	Tue 10/23/18	Sat 11/17/18	1347SS,1349	No										
1349	Pintu Besi	25 days	Fri 9/28/18	Tue 10/23/18	1345	No										
1350	Pengecatan	25 days	Sat 11/17/18	Wed 12/12/18	1338,1344,1345,1349	No										
1351	Finish Lantai 18A	1 day	Sun 2/10/19	Sun 2/10/19	1300,1326,1333,1349	Yes										

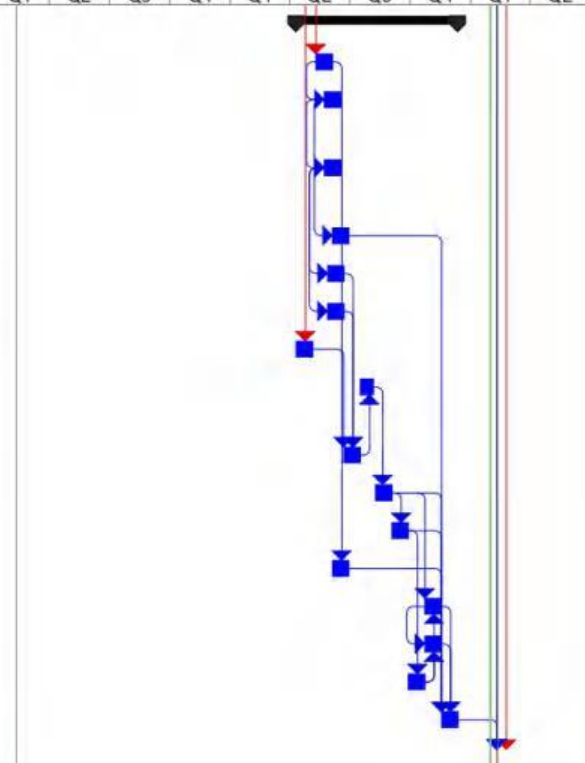

Lampiran 21. Daftar Aktivitas, *Network Planning, Predecessor* Lantai 19

PEMILIK		COMPOSITE SCHEDULE					KONSULTAN MK									
PODO MORO CITY		FINISHING-ME TOWER 3L					JAYA CM									
ID	Task Name	Duration	Start	Finish	Predecessors	Critical	2017				2018				2019	
							Q1	Q2	Q3	Q4	Q1	Q2	Q3	Q4	Q1	Q2
1	SCHEDULE FINISHING-ME TOWER 3L	411 days	Mon 1/1/18	Fri 2/15/19		Yes										
2	LINCOLN (Lantai LM)	411 days	Mon 1/1/18	Fri 2/15/19		Yes										
3	LANTAI 1	321 days	Mon 1/1/18	Sat 11/17/18		No										
74	LANTAI 2	321 days	Sat 1/6/18	Thu 11/22/18	35S+5 days	No										
145	LANTAI 3	321 days	Thu 1/11/18	Tue 11/27/18	74SS+5 days	No										
216	LANTAI 5	321 days	Tue 1/16/18	Sun 12/2/18	145SS+5 days	No										
287	LANTAI 6	321 days	Sun 1/21/18	Fri 12/7/18	216SS+5 days	No										
358	LANTAI 7	321 days	Fri 1/26/18	Wed 12/12/18	287SS+5 days	No										
429	LANTAI 8	321 days	Wed 1/31/18	Mon 12/17/18	358SS+5 days	No										
500	LANTAI 9	321 days	Mon 2/5/18	Sat 12/22/18	429SS+5 days	No										
571	LANTAI 10	321 days	Sat 2/10/18	Thu 12/27/18	500SS+5 days	No										
642	LANTAI 11	321 days	Thu 2/15/18	Tue 1/1/19	571SS+5 days	No										
713	LANTAI 11	321 days	Thu 2/15/18	Tue 1/1/19	571SS+5 days	No										
784	LANTAI 12	321 days	Tue 2/20/18	Sun 1/6/19	713SS+5 days	No										
855	LANTAI 13	321 days	Sun 2/25/18	Fri 1/11/19	784SS+5 days	No										
926	LANTAI 14	321 days	Fri 3/2/18	Wed 1/16/19	855SS+5 days	No										
997	LANTAI 15	321 days	Wed 3/7/18	Mon 1/21/19	926SS+5 days	No										
1068	LANTAI 16	321 days	Mon 3/12/18	Sat 1/26/19	997SS+5 days	No										
1139	LANTAI 17	321 days	Sat 3/17/18	Thu 1/31/19	1068SS+5 days	No										
1210	LANTAI 18	321 days	Thu 3/22/18	Tue 2/5/19	1139SS+5 days	No										
1281	LANTAI 18A	321 days	Tue 3/27/18	Sun 2/10/19	1210SS+5 days	No										
1352	LANTAI 19	321 days	Sun 4/1/18	Fri 2/15/19	1281SS+5 days	Yes										
1353	AREA UNIT	285 days	Sun 4/1/18	Thu 1/10/19		Yes										
1354	MARKING	15 days	Sun 4/1/18	Sun 4/15/18		Yes										
1355	PEKERJAAN DINDING	270 days	Mon 4/16/18	Thu 1/10/19		Yes										
1356	PASANG BATA	30 days	Mon 4/16/18	Tue 5/15/18	1354	Yes										

ID	Task Name	Duration	Start	Finish	Predecessors	Critical	2017		2018				2019				
							Q1	Q2	Q3	Q4	Q1	Q2	Q3	Q4	Q1	Q2	
1357	PLESTER/RENDER	30 days	Fri 6/15/18	Sat 7/14/18	1356,1360,1361,1362	No											
1358	CAT DINDING	30 days	Sun 7/15/18	Mon 8/13/18	1357	No											
1359	MEP DINDING	240 days	Wed 5/16/18	Thu 1/10/19		No											
1360	ELEKTRONIK	30 days	Wed 5/16/18	Thu 6/14/18	1356	No											
1361	ELEKTRIKAL	30 days	Wed 5/16/18	Thu 6/14/18	1356	No											
1362	MVAC	30 days	Wed 5/16/18	Thu 6/14/18	1356	No											
1363	FIXTURES MEP DALAM DINDING	30 days	Wed 12/12/18	Thu 1/10/19	1360,1361,1362,1363	No											
1364	TEST MEP	30 days	Fri 6/15/18	Sat 7/14/18	1360,1361,1362	No											
1365	PINTU KAYU	60 days	Sat 10/13/18	Tue 12/11/18		No											
1366	KUSEN PINTU	30 days	Sat 10/13/18	Sun 11/11/18	1357,1370	No											
1367	DAUN PINTU	30 days	Sat 10/13/18	Sun 11/11/18	1358FF,1366SS	No											
1368	ACESSORIES	30 days	Mon 11/12/18	Tue 12/11/18	1367	No											
1369	PEKERJAAN LANTAI	44 days	Thu 9/13/18	Fri 10/26/18		No											
1370	PASANG MARBEL	30 days	Thu 9/13/18	Fri 10/12/18	1374	No											
1371	POLES MARBEL	30 days	Thu 9/27/18	Fri 10/26/18	1370SS+14 days	No											
1372	PEKERJAAN PLAFOND	240 days	Wed 5/16/18	Thu 1/10/19		No											
1373	PASANG RANGKA	30 days	Sun 7/15/18	Mon 8/13/18	1357,1378,1381	No											
1374	TUTUP PLAFOND	30 days	Tue 8/14/18	Wed 9/12/18	1373,1383	No											
1375	COMPOUND	30 days	Thu 9/13/18	Fri 10/12/18	1374	No											
1376	CAT PLAFOND	30 days	Sat 10/13/18	Sun 11/11/18	1375	No											
1377	MEP DALAM PLAFOND	240 days	Wed 5/16/18	Thu 1/10/19		No											
1378	ELEKTRIKAL	30 days	Wed 5/16/18	Thu 6/14/18	1356,1361SS	No											
1379	ELEKTRONIK	30 days	Wed 5/16/18	Thu 6/14/18	1356,1360SS	No											
1380	MVAC	30 days	Wed 5/16/18	Thu 6/14/18	1356,1362SS	No											
1381	PLPK	30 days	Wed 5/16/18	Thu 6/14/18	1356	No											

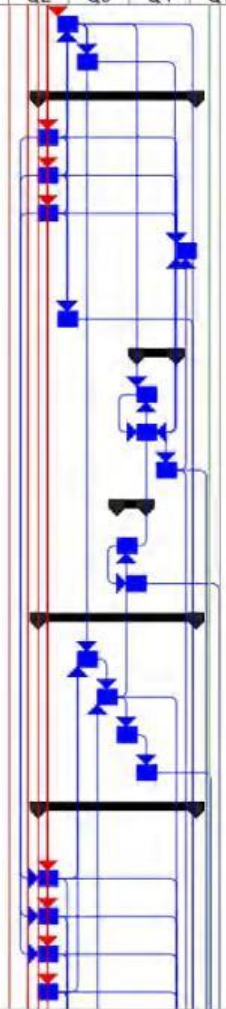

ID	Task Name	Duration	Start	Finish	Predecessors	Critical	2017		2018				2019			
							Q1	Q2	Q3	Q4	Q1	Q2	Q3	Q4	Q1	Q2
1382	FIXTURE MEP DALAM PLAFOND	30 days	Wed 12/12/18	Thu 1/10/19	1368,1374,1378,13	No										
1383	TEST MEP	30 days	Fri 6/15/18	Sat 7/14/18	1378,1379,1380,13	No										
1384	AREA KAMAR MANDI	275 days	Wed 5/16/18	Thu 2/14/19		Yes										
1385	CORING	20 days	Wed 5/16/18	Mon 6/4/18	1356	Yes										
1386	PASANG PIPA	25 days	Tue 6/5/18	Fri 6/29/18	1385	Yes										
1387	TEST BOCOR	20 days	Sat 6/30/18	Thu 7/19/18	1386	Yes										
1388	GROUTING	25 days	Fri 7/20/18	Mon 8/13/18	1387	Yes										
1389	PASANG HT DINDING	25 days	Fri 9/28/18	Mon 10/22/18	1356SS,1387,1391	Yes										
1390	WATER PROOFING	25 days	Tue 8/14/18	Fri 9/7/18	1388	Yes										
1391	TEST WATER PROOFING	20 days	Sat 9/8/18	Thu 9/27/18	1390	Yes										
1392	PASANG HT LANTAI	25 days	Wed 12/12/18	Sat 1/5/19	1389,1391,1394	Yes										
1393	PASANG RANGKA PLAFOND	25 days	Tue 10/23/18	Fri 11/16/18	1389	Yes										
1394	TUTUP PLAFOND	25 days	Sat 11/17/18	Tue 12/11/18	1393	Yes										
1395	CAT PLAFOND	25 days	Wed 12/12/18	Sat 1/5/19	1376FF,1394	No										
1396	PASANG PINTU	20 days	Sun 1/6/19	Fri 1/25/19	1357,1364,1392	Yes										
1397	PASANG SANITARY	20 days	Sat 1/26/19	Thu 2/14/19	1368,1396	Yes										
1398	AREA FAÇADE/BALKON	125 days	Mon 4/16/18	Sat 8/18/18		No										
1399	PASANG PC PANEL	25 days	Mon 4/16/18	Thu 5/10/18	1354	No										
1400	PASANG JENDELA ALUMUNIUM	25 days	Fri 5/11/18	Mon 6/4/18	1399	No										
1401	PASANG RAILING BALKON	30 days	Fri 5/11/18	Sat 6/9/18	1399	No										
1402	PASANG HT LANTAI	25 days	Wed 7/25/18	Sat 8/18/18	1404	No										
1403	WATER PROOFING	25 days	Sun 6/10/18	Wed 7/4/18	1401	No										
1404	TEST WATER PROOFING	20 days	Thu 7/5/18	Tue 7/24/18	1403	No										

ID	Task Name	Duration	Start	Finish	Predecessors	Critical	2017		2018				2019			
							Q1	Q2	Q3	Q4	Q1	Q2	Q3	Q4	Q1	Q2
1405	AREA CORIDOR	245.5 days	Mon 4/16/18	Mon 12/17/18		No										
1406	Pasang Bata	25 days	Wed 5/16/18	Sat 6/9/18	1354FS+30 days	No										
1407	Pasang Conduit + Inbodur di Dinding	25 days	Mon 5/28/18	Fri 6/22/18	1406SS+50%	No										
1408	Pasang Conduit di Plafond	25 days	Mon 5/28/18	Fri 6/22/18	1407SS	No										
1409	Render/Plaster	25 days	Sun 6/10/18	Wed 7/4/18	1407SS+50%	No										
1410	Instalasi Kabel	25 days	Sat 6/2/18	Wed 6/27/18	1408SS+5 days	No										
1411	Instalasi MVAC	25 days	Sat 6/2/18	Wed 6/27/18	1408SS+5 days	No										
1412	Pipa Fire Fighting	25 days	Mon 4/16/18	Thu 5/10/18	1354	No										
1413	Test Parsial MEP dalam Plafond	20 days	Sun 7/22/18	Sat 8/11/18	1414	No										
1414	Rangka Plafond	25 days	Wed 6/27/18	Sun 7/22/18	1410,1411,1412	No										
1415	Tutup Plafond	25 days	Tue 8/14/18	Sat 9/8/18	1413FS+3 days	No										
1416	Pasang HT/Keramik	25 days	Sat 9/8/18	Wed 10/3/18	1415	No										
1417	Railing Tangga	25 days	Sun 6/10/18	Wed 7/4/18	1406	No										
1418	ME Fixture di Plafond	25 days	Sun 10/28/18	Thu 11/22/18	1415,1420	No										
1419	ME Fixture di Dinding	25 days	Sun 10/28/18	Thu 11/22/18	1418SS,1420	No										
1420	Pintu Besi	25 days	Wed 10/3/18	Sun 10/28/18	1416	No										
1421	Pengecatan	25 days	Thu 11/22/18	Mon 12/17/18	1409,1415,1416,1417	No										
1422	Finish Lantai 19	1 day	Fri 2/15/19	Fri 2/15/19	1371,1397,1404,1417	Yes										

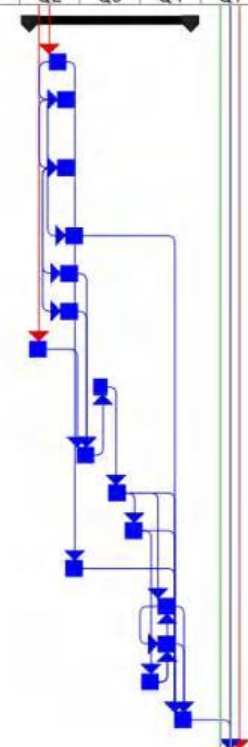

Lampiran 22. Daftar Aktivitas, *Network Planning*, Predecessor Lantai 19A

PEMILIK		COMPOSITE SCHEDULE					KONSULTAN MK									
PODO MORO CITY DELI MEGAH		FINISHING-ME TOWER 3L					JAYA CM									
ID	Task Name	Duration	Start	Finish	Predecessors	Critical	2017				2018				2019	
							Q1	Q2	Q3	Q4	Q1	Q2	Q3	Q4	Q1	Q2
1	SCHEDULE FINISHING-ME TOWER 3L	416 days	Mon 1/1/18	Wed 2/20/19		Yes										
2	LINCOLN (Lantai LM)	416 days	Mon 1/1/18	Wed 2/20/19		Yes										
3	LANTAI 1	321 days	Mon 1/1/18	Sat 11/17/18		No										
74	LANTAI 2	321 days	Sat 1/6/18	Thu 11/22/18	3SS+5 days	No										
145	LANTAI 3	321 days	Thu 1/11/18	Tue 11/27/18	74SS+5 days	No										
216	LANTAI 5	321 days	Tue 1/16/18	Sun 12/2/18	145SS+5 days	No										
287	LANTAI 6	321 days	Sun 1/21/18	Fri 12/7/18	216SS+5 days	No										
358	LANTAI 7	321 days	Fri 1/26/18	Wed 12/12/18	287SS+5 days	No										
429	LANTAI 8	321 days	Wed 1/31/18	Mon 12/17/18	358SS+5 days	No										
500	LANTAI 9	321 days	Mon 2/5/18	Sat 12/22/18	429SS+5 days	No										
571	LANTAI 10	321 days	Sat 2/10/18	Thu 12/27/18	500SS+5 days	No										
642	LANTAI 11	321 days	Thu 2/15/18	Tue 1/1/19	571SS+5 days	No										
713	LANTAI 11	321 days	Thu 2/15/18	Tue 1/1/19	571SS+5 days	No										
784	LANTAI 12	321 days	Tue 2/20/18	Sun 1/6/19	713SS+5 days	No										
855	LANTAI 13	321 days	Sun 2/25/18	Fri 1/11/19	784SS+5 days	No										
926	LANTAI 14	321 days	Fri 3/2/18	Wed 1/16/19	855SS+5 days	No										
997	LANTAI 15	321 days	Wed 3/7/18	Mon 1/21/19	926SS+5 days	No										
1068	LANTAI 16	321 days	Mon 3/12/18	Sat 1/26/19	997SS+5 days	No										
1139	LANTAI 17	321 days	Sat 3/17/18	Thu 1/31/19	1068SS+5 days	No										
1210	LANTAI 18	321 days	Thu 3/22/18	Tue 2/5/19	1139SS+5 days	No										
1281	LANTAI 18A	321 days	Tue 3/27/18	Sun 2/10/19	1210SS+5 days	No										
1352	LANTAI 19	321 days	Sun 4/1/18	Fri 2/15/19	1281SS+5 days	No										
1423	LANTAI 19A	321 days	Fri 4/6/18	Wed 2/20/19	1352SS+5 days	Yes										
1424	AREA UNIT	285 days	Fri 4/6/18	Tue 1/15/19		Yes										
1425	MARKING	15 days	Fri 4/6/18	Fri 4/20/18		Yes										
1426	PEKERJAAN DINDING	270 days	Sat 4/21/18	Tue 1/15/19		Yes										

ID	Task Name	Duration	Start	Finish	Predecessors	Critical	2017				2018				2019	
							Q1	Q2	Q3	Q4	Q1	Q2	Q3	Q4	Q1	Q2
1427	PASANG BATA	30 days	Sat 4/21/18	Sun 5/20/18	1425	Yes										
1428	PLESTER/RENDER	30 days	Wed 6/20/18	Thu 7/19/18	1427,1431,1432,14	No										
1429	CAT DINDING	30 days	Fri 7/20/18	Sat 8/18/18	1428	No										
1430	MEP DINDING	240 days	Mon 5/21/18	Tue 1/15/19		No										
1431	ELEKTRONIK	30 days	Mon 5/21/18	Tue 6/19/18	1427	No										
1432	ELEKTRIKAL	30 days	Mon 5/21/18	Tue 6/19/18	1427	No										
1433	MVAC	30 days	Mon 5/21/18	Tue 6/19/18	1427	No										
1434	FIXTURES MEP DALAM DINDING	30 days	Mon 12/17/18	Tue 1/15/19	1431,1432,1433,14	No										
1435	TEST MEP	30 days	Wed 6/20/18	Thu 7/19/18	1431,1432,1433	No										
1436	PINTU KAYU	60 days	Thu 10/18/18	Sun 12/16/18		No										
1437	KUSEN PINTU	30 days	Thu 10/18/18	Fri 11/16/18	1428,1441	No										
1438	DAUN PINTU	30 days	Thu 10/18/18	Fri 11/16/18	1429FF,1437SS	No										
1439	ACESSORIES	30 days	Sat 11/17/18	Sun 12/16/18	1438	No										
1440	PEKERJAAN LANTAI	44 days	Tue 9/18/18	Wed 10/31/18		No										
1441	PASANG MARBEL	30 days	Tue 9/18/18	Wed 10/17/18	1445	No										
1442	POLES MARBEL	30 days	Tue 10/2/18	Wed 10/31/18	1441SS+14 days	No										
1443	PEKERJAAN PLAFOND	240 days	Mon 5/21/18	Tue 1/15/19		No										
1444	PASANG RANGKA	30 days	Fri 7/20/18	Sat 8/18/18	1428,1449,1452	No										
1445	TUTUP PLAFOND	30 days	Sun 8/19/18	Mon 9/17/18	1444,1454	No										
1446	COMPOUND	30 days	Tue 9/18/18	Wed 10/17/18	1445	No										
1447	CAT PLAFOND	30 days	Thu 10/18/18	Fri 11/16/18	1446	No										
1448	MEP DALAM PLAFOND	240 days	Mon 5/21/18	Tue 1/15/19		No										
1449	ELEKTRIKAL	30 days	Mon 5/21/18	Tue 6/19/18	1427,1432SS	No										
1450	ELEKTRONIK	30 days	Mon 5/21/18	Tue 6/19/18	1427,1431SS	No										
1451	MVAC	30 days	Mon 5/21/18	Tue 6/19/18	1427,1433SS	No										

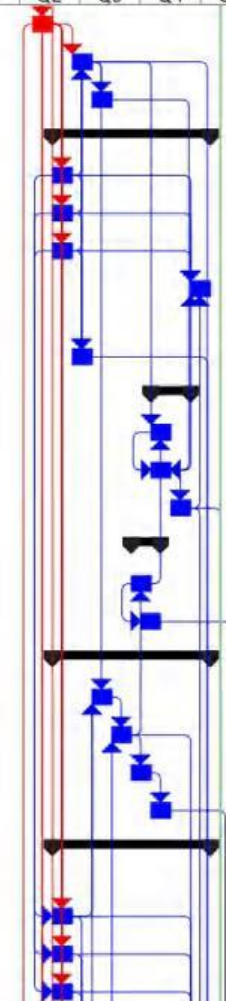

ID	Task Name	Duration	Start	Finish	Predecessors	Critical	2017		2018				2019			
							Q1	Q2	Q3	Q4	Q1	Q2	Q3	Q4	Q1	Q2
1452	PLPK	30 days	Mon 5/21/18	Tue 6/19/18	1427	No										
1453	FIXTURE MEP DALAM PLAFOND	30 days	Mon 12/17/18	Tue 1/15/19	1439,1445,1449,1451	No										
1454	TEST MEP	30 days	Wed 6/20/18	Thu 7/19/18	1449,1450,1451,1452	No										
1455	AREA KAMAR MANDI	275 days	Mon 5/21/18	Tue 2/19/19		Yes										
1456	CORING	20 days	Mon 5/21/18	Sat 6/9/18	1427	Yes										
1457	PASANG PIPA	25 days	Sun 6/10/18	Wed 7/4/18	1456	Yes										
1458	TEST BOCOR	20 days	Thu 7/5/18	Tue 7/24/18	1457	Yes										
1459	GROUTING	25 days	Wed 7/25/18	Sat 8/18/18	1458	Yes										
1460	PASANG HT DINDING	25 days	Wed 10/3/18	Sat 10/27/18	1427SS,1458,1462	Yes										
1461	WATER PROOFING	25 days	Sun 8/19/18	Wed 9/12/18	1459	Yes										
1462	TEST WATER PROOFING	20 days	Thu 9/13/18	Tue 10/2/18	1461	Yes										
1463	PASANG HT LANTAI	25 days	Mon 12/17/18	Thu 1/10/19	1460,1462,1465	Yes										
1464	PASANG RANGKA PLAFOND	25 days	Sun 10/28/18	Wed 11/21/18	1460	Yes										
1465	TUTUP PLAFOND	25 days	Thu 11/22/18	Sun 12/16/18	1464	Yes										
1466	CAT PLAFOND	25 days	Mon 12/17/18	Thu 1/10/19	1447FF,1465	No										
1467	PASANG PINTU	20 days	Fri 1/11/19	Wed 1/30/19	1428,1435,1463	Yes										
1468	PASANG SANITARY	20 days	Thu 1/31/19	Tue 2/19/19	1439,1467	Yes										
1469	AREA FAÇADE/BALKON	125 days	Sat 4/21/18	Thu 8/23/18		No										
1470	PASANG PC PANEL	25 days	Sat 4/21/18	Tue 5/15/18	1425	No										
1471	PASANG JENDELA ALUMINIUM	25 days	Wed 5/16/18	Sat 6/9/18	1470	No										
1472	PASANG RAILING BALKON	30 days	Wed 5/16/18	Thu 6/14/18	1470	No										
1473	PASANG HT LANTAI	25 days	Mon 7/30/18	Thu 8/23/18	1475	No										
1474	WATER PROOFING	25 days	Fri 6/15/18	Mon 7/9/18	1472	No										

ID	Task Name	Duration	Start	Finish	Predecessors	Critical	2017		2018				2019			
							Q1	Q2	Q3	Q4	Q1	Q2	Q3	Q4	Q1	Q2
1475	TEST WATER PROOFING	20 days	Tue 7/10/18	Sun 7/29/18	1474	No										
1476	AREA CORIDOR	245.5 days	Sat 4/21/18	Sat 12/22/18		No										
1477	Pasang Bata	25 days	Mon 5/21/18	Thu 6/14/18	1425FS+30 days	No										
1478	Pasang Conduit + Inbodus di Dinding	25 days	Sat 6/2/18	Wed 6/27/18	1477SS+50%	No										
1479	Pasang Conduit di Plafond	25 days	Sat 6/2/18	Wed 6/27/18	1478SS	No										
1480	Render/Plaster	25 days	Fri 6/15/18	Mon 7/9/18	1478SS+50%	No										
1481	Instalasi Kabel	25 days	Thu 6/7/18	Mon 7/2/18	1479SS+5 days	No										
1482	Instalasi MVAC	25 days	Thu 6/7/18	Mon 7/2/18	1479SS+5 days	No										
1483	Pipa Fire Fighting	25 days	Sat 4/21/18	Tue 5/15/18	1425	No										
1484	Test Parsial MEP dalam Plafond	20 days	Fri 7/27/18	Thu 8/16/18	1485	No										
1485	Rangka Plafond	25 days	Mon 7/2/18	Fri 7/27/18	1481,1482,1483	No										
1486	Tutup Plafond	25 days	Sun 8/19/18	Thu 9/13/18	1484FS+3 days	No										
1487	Pasang HT/Keramik	25 days	Thu 9/13/18	Mon 10/8/18	1486	No										
1488	Railing Tangga	25 days	Fri 6/15/18	Mon 7/9/18	1477	No										
1489	ME Fixture di Plafond	25 days	Fri 11/2/18	Tue 11/27/18	1486,1491	No										
1490	ME Fixture di Dinding	25 days	Fri 11/2/18	Tue 11/27/18	1489SS,1491	No										
1491	Pintu Besi	25 days	Mon 10/8/18	Fri 11/2/18	1487	No										
1492	Pengecatan	25 days	Tue 11/27/18	Sat 12/22/18	1480,1486,1487,1491	No										
1493	Finish Lantai 19A	1 day	Wed 2/20/19	Wed 2/20/19	1442,1468,1475,1492	Yes										

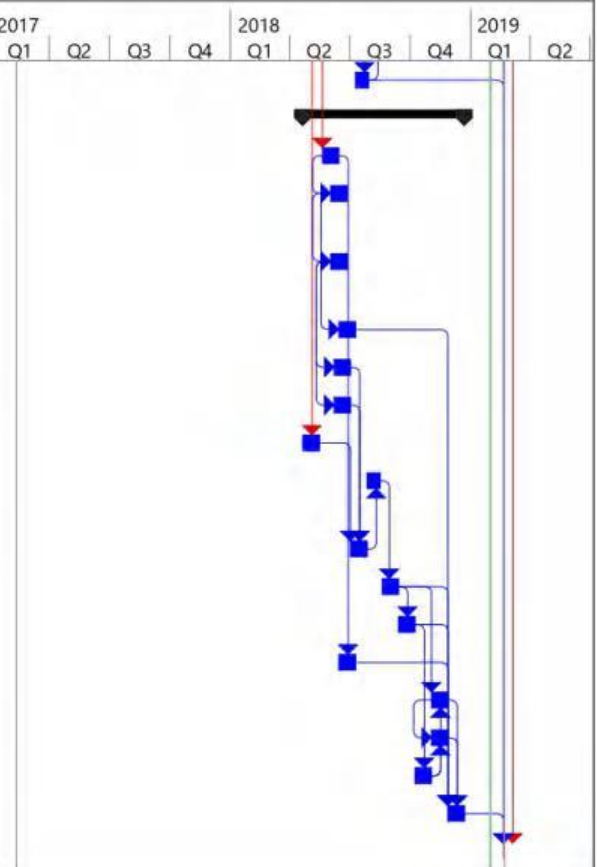

Lampiran 23. Daftar Aktivitas, *Network Planning, Predecessor* Lantai 20

PEMILIK		COMPOSITE SCHEDULE					KONSULTAN MK									
PODO MORO CITY DELI MEGAH		FINISHING-ME TOWER 3L					JAYA CM									
ID	Task Name	Duration	Start	Finish	Predecessors	Critical	2017				2018				2019	
							Q1	Q2	Q3	Q4	Q1	Q2	Q3	Q4	Q1	Q2
1	SCHEDULE FINISHING-ME TOWER 3L	421 days	Mon 1/1/18	Mon 2/25/19		Yes										
2	LINCOLN (Lantai LM)	421 days	Mon 1/1/18	Mon 2/25/19		Yes										
3	LANTAI 1	321 days	Mon 1/1/18	Sat 11/17/18		No										
74	LANTAI 2	321 days	Sat 1/6/18	Thu 11/22/18	35S+5 days	No										
145	LANTAI 3	321 days	Thu 1/11/18	Tue 11/27/18	74SS+5 days	No										
216	LANTAI 5	321 days	Tue 1/16/18	Sun 12/2/18	145SS+5 days	No										
287	LANTAI 6	321 days	Sun 1/21/18	Fri 12/7/18	216SS+5 days	No										
358	LANTAI 7	321 days	Fri 1/26/18	Wed 12/12/18	287SS+5 days	No										
429	LANTAI 8	321 days	Wed 1/31/18	Mon 12/17/18	358SS+5 days	No										
500	LANTAI 9	321 days	Mon 2/5/18	Sat 12/22/18	429SS+5 days	No										
571	LANTAI 10	321 days	Sat 2/10/18	Thu 12/27/18	500SS+5 days	No										
642	LANTAI 11	321 days	Thu 2/15/18	Tue 1/1/19	571SS+5 days	No										
713	LANTAI 11	321 days	Thu 2/15/18	Tue 1/1/19	571SS+5 days	No										
784	LANTAI 12	321 days	Tue 2/20/18	Sun 1/6/19	713SS+5 days	No										
855	LANTAI 13	321 days	Sun 2/25/18	Fri 1/11/19	784SS+5 days	No										
926	LANTAI 14	321 days	Fri 3/2/18	Wed 1/16/19	855SS+5 days	No										
997	LANTAI 15	321 days	Wed 3/7/18	Mon 1/21/19	926SS+5 days	No										
1068	LANTAI 16	321 days	Mon 3/12/18	Sat 1/26/19	997SS+5 days	No										
1139	LANTAI 17	321 days	Sat 3/17/18	Thu 1/31/19	1068SS+5 days	No										
1210	LANTAI 18	321 days	Thu 3/22/18	Tue 2/5/19	1139SS+5 days	No										
1281	LANTAI 18A	321 days	Tue 3/27/18	Sun 2/10/19	1210SS+5 days	No										
1352	LANTAI 19	321 days	Sun 4/1/18	Fri 2/15/19	1281SS+5 days	No										
1423	LANTAI 19A	321 days	Fri 4/6/18	Wed 2/20/19	1352SS+5 days	No										
1494	LANTAI 20	321 days	Wed 4/11/18	Mon 2/25/19	1423SS+5 days	Yes										
1495	AREA UNIT	285 days	Wed 4/11/18	Sun 1/20/19		Yes										
1496	MARKING	15 days	Wed 4/11/18	Wed 4/25/18		Yes										

ID	Task Name	Duration	Start	Finish	Predecessors	Critical	2017		2018				2019			
							Q1	Q2	Q3	Q4	Q1	Q2	Q3	Q4	Q1	Q2
1497	PEKERJAAN DINDING	270 days	Thu 4/26/18	Sun 1/20/19		Yes										
1498	PASANG BATA	30 days	Thu 4/26/18	Fri 5/25/18	1496	Yes										
1499	PLESTER/RENDER	30 days	Mon 6/25/18	Tue 7/24/18	1498,1502,1503,1504	No										
1500	CAT DINDING	30 days	Wed 7/25/18	Thu 8/23/18	1499	No										
1501	MEP DINDING	240 days	Sat 5/26/18	Sun 1/20/19		No										
1502	ELEKTRONIK	30 days	Sat 5/26/18	Sun 6/24/18	1498	No										
1503	ELEKTRIKAL	30 days	Sat 5/26/18	Sun 6/24/18	1498	No										
1504	MVAC	30 days	Sat 5/26/18	Sun 6/24/18	1498	No										
1505	FIXTURES MEP DALAM DINDING	30 days	Sat 12/22/18	Sun 1/20/19	1502,1503,1504,1506	No										
1506	TEST MEP	30 days	Mon 6/25/18	Tue 7/24/18	1502,1503,1504	No										
1507	PINTU KAYU	60 days	Tue 10/23/18	Fri 12/21/18		No										
1508	KUSEN PINTU	30 days	Tue 10/23/18	Wed 11/21/18	1499,1512	No										
1509	DAUN PINTU	30 days	Tue 10/23/18	Wed 11/21/18	1500FF,1508SS	No										
1510	ACESSORIES	30 days	Thu 11/22/18	Fri 12/21/18	1509	No										
1511	PEKERJAAN LANTAI	44 days	Sun 9/23/18	Mon 11/5/18		No										
1512	PASANG MARBEL	30 days	Sun 9/23/18	Mon 10/22/18	1516	No										
1513	POLES MARBEL	30 days	Sun 10/7/18	Mon 11/5/18	1512SS+14 days	No										
1514	PEKERJAAN PLAFOND	240 days	Sat 5/26/18	Sun 1/20/19		No										
1515	PASANG RANGKA	30 days	Wed 7/25/18	Thu 8/23/18	1499,1520,1523	No										
1516	TUTUP PLAFOND	30 days	Fri 8/24/18	Sat 9/22/18	1515,1525	No										
1517	COMPOUND	30 days	Sun 9/23/18	Mon 10/22/18	1516	No										
1518	CAT PLAFOND	30 days	Tue 10/23/18	Wed 11/21/18	1517	No										
1519	MEP DALAM PLAFOND	240 days	Sat 5/26/18	Sun 1/20/19		No										
1520	ELEKTRIKAL	30 days	Sat 5/26/18	Sun 6/24/18	1498,1503SS	No										
1521	ELEKTRONIK	30 days	Sat 5/26/18	Sun 6/24/18	1498,1502SS	No										

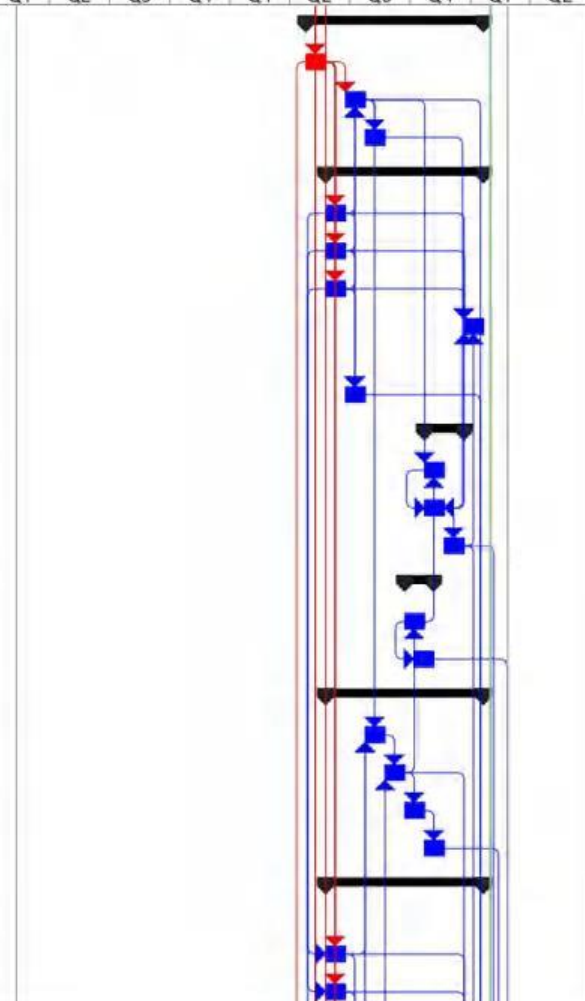

ID	Task Name	Duration	Start	Finish	Predecessors	Critical	2017		2018				2019			
							Q1	Q2	Q3	Q4	Q1	Q2	Q3	Q4	Q1	Q2
1522	MVAC	30 days	Sat 5/26/18	Sun 6/24/18	1498,1504SS	No										
1523	PLPK	30 days	Sat 5/26/18	Sun 6/24/18	1498	No										
1524	FIXTURE MEP DALAM PLAFOND	30 days	Sat 12/22/18	Sun 1/20/19	1510,1516,1520,15	No										
1525	TEST MEP	30 days	Mon 6/25/18	Tue 7/24/18	1520,1521,1522,15	No										
1526	AREA KAMAR MANDI	275 days	Sat 5/26/18	Sun 2/24/19		Yes										
1527	CORING	20 days	Sat 5/26/18	Thu 6/14/18	1498	Yes										
1528	PASANG PIPA	25 days	Fri 6/15/18	Mon 7/9/18	1527	Yes										
1529	TEST BOCOR	20 days	Tue 7/10/18	Sun 7/29/18	1528	Yes										
1530	GROUTING	25 days	Mon 7/30/18	Thu 8/23/18	1529	Yes										
1531	PASANG HT DINDING	25 days	Mon 10/8/18	Thu 11/1/18	1498SS,1529,1533	Yes										
1532	WATER PROOFING	25 days	Fri 8/24/18	Mon 9/17/18	1530	Yes										
1533	TEST WATER PROOFING	20 days	Tue 9/18/18	Sun 10/7/18	1532	Yes										
1534	PASANG HT LANTAI	25 days	Sat 12/22/18	Tue 1/15/19	1531,1533,1536	Yes										
1535	PASANG RANGKA PLAFOND	25 days	Fri 11/2/18	Mon 11/26/18	1531	Yes										
1536	TUTUP PLAFOND	25 days	Tue 11/27/18	Fri 12/21/18	1535	Yes										
1537	CAT PLAFOND	25 days	Sat 12/22/18	Tue 1/15/19	1518FF,1536	No										
1538	PASANG PINTU	20 days	Wed 1/16/19	Mon 2/4/19	1499,1506,1534	Yes										
1539	PASANG SANITARY	20 days	Tue 2/5/19	Sun 2/24/19	1510,1538	Yes										
1540	AREA FAÇADE/BALKON	125 days	Thu 4/26/18	Tue 8/28/18		No										
1541	PASANG PC PANEL	25 days	Thu 4/26/18	Sun 5/20/18	1496	No										
1542	PASANG JENDELA ALUMINIUM	25 days	Mon 5/21/18	Thu 6/14/18	1541	No										
1543	PASANG RAILING BALKON	30 days	Mon 5/21/18	Tue 6/19/18	1541	No										
1544	PASANG HT LANTAI	25 days	Sat 8/4/18	Tue 8/28/18	1546	No										

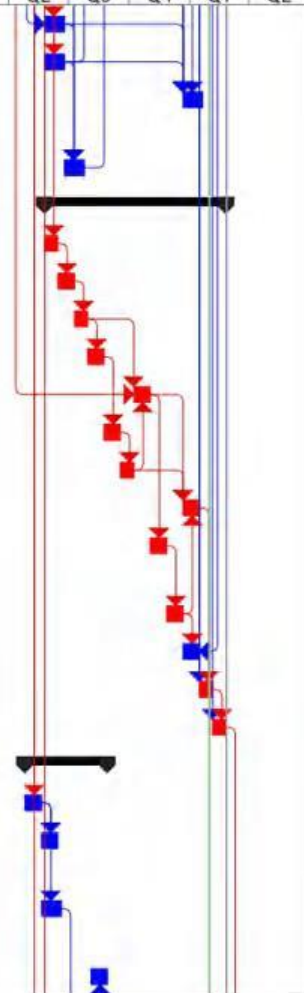

ID	Task Name	Duration	Start	Finish	Predecessors	Critical	2017		2018				2019			
							Q1	Q2	Q3	Q4	Q1	Q2	Q3	Q4	Q1	Q2
1545	WATER PROOFING	25 days	Wed 6/20/18	Sat 7/14/18	1543	No										
1546	TEST WATER PROOFING	20 days	Sun 7/15/18	Fri 8/3/18	1545	No										
1547	AREA CORIDOR	245.5 days	Thu 4/26/18	Thu 12/27/18		No										
1548	Pasang Bata	25 days	Sat 5/26/18	Tue 6/19/18	1496FS+30 days	No										
1549	Pasang Conduit + Inbodus di Dinding	25 days	Thu 6/7/18	Mon 7/2/18	1548SS+50%	No										
1550	Pasang Conduit di Plafond	25 days	Thu 6/7/18	Mon 7/2/18	1549SS	No										
1551	Render/Plaster	25 days	Wed 6/20/18	Sat 7/14/18	1549SS+50%	No										
1552	Instalasi Kabel	25 days	Tue 6/12/18	Sat 7/7/18	1550SS+5 days	No										
1553	Instalasi MVAC	25 days	Tue 6/12/18	Sat 7/7/18	1550SS+5 days	No										
1554	Pipa Fire Fighting	25 days	Thu 4/26/18	Sun 5/20/18	1496	No										
1555	Test Parsial MEP dalam Plafond	20 days	Wed 8/1/18	Tue 8/21/18	1556	No										
1556	Rangka Plafond	25 days	Sat 7/7/18	Wed 8/1/18	1552,1553,1554	No										
1557	Tutup Plafond	25 days	Fri 8/24/18	Tue 9/18/18	1555FS+3 days	No										
1558	Pasang HT/Keramik	25 days	Tue 9/18/18	Sat 10/13/18	1557	No										
1559	Railing Tangga	25 days	Wed 6/20/18	Sat 7/14/18	1548	No										
1560	ME Fixture di Plafond	25 days	Wed 11/7/18	Sun 12/2/18	1557,1562	No										
1561	ME Fixture di Dinding	25 days	Wed 11/7/18	Sun 12/2/18	1560SS,1562	No										
1562	Pintu Besi	25 days	Sat 10/13/18	Wed 11/7/18	1558	No										
1563	Pengecatan	25 days	Sun 12/2/18	Thu 12/27/18	1551,1557,1558,1561	No										
1564	Finish Lantai 20	1 day	Mon 2/25/19	Mon 2/25/19	1513,1539,1546,1551	Yes										

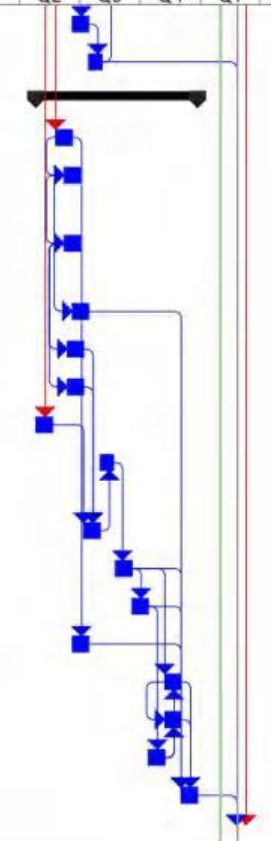

Lampiran 24. Daftar Aktivitas, *Network Planning, Predecessor* Lantai 21

PEMILIK		COMPOSITE SCHEDULE					KONSULTAN MK									
PODO MORO CITY		FINISHING-ME TOWER 3L					JAYA CM									
ID	Task Name	Duration	Start	Finish	Predecessors	Critical	2017				2018				2019	
							Q1	Q2	Q3	Q4	Q1	Q2	Q3	Q4	Q1	Q2
1	SCHEDULE FINISHING-ME TOWER 3L	426 days	Mon 1/1/18	Sat 3/2/19		Yes										
2	LINCOLN (Lantai LM)	426 days	Mon 1/1/18	Sat 3/2/19		Yes										
3	LANTAI 1	321 days	Mon 1/1/18	Sat 11/17/18		No										
74	LANTAI 2	321 days	Sat 1/6/18	Thu 11/22/18	3SS+5 days	No										
145	LANTAI 3	321 days	Thu 1/11/18	Tue 11/27/18	74SS+5 days	No										
216	LANTAI 5	321 days	Tue 1/16/18	Sun 12/2/18	145SS+5 days	No										
287	LANTAI 6	321 days	Sun 1/21/18	Fri 12/7/18	216SS+5 days	No										
358	LANTAI 7	321 days	Fri 1/26/18	Wed 12/12/18	287SS+5 days	No										
429	LANTAI 8	321 days	Wed 1/31/18	Mon 12/17/18	358SS+5 days	No										
500	LANTAI 9	321 days	Mon 2/5/18	Sat 12/22/18	429SS+5 days	No										
571	LANTAI 10	321 days	Sat 2/10/18	Thu 12/27/18	500SS+5 days	No										
642	LANTAI 11	321 days	Thu 2/15/18	Tue 1/1/19	571SS+5 days	No										
713	LANTAI 11	321 days	Thu 2/15/18	Tue 1/1/19	571SS+5 days	No										
784	LANTAI 12	321 days	Tue 2/20/18	Sun 1/6/19	713SS+5 days	No										
855	LANTAI 13	321 days	Sun 2/25/18	Fri 1/11/19	784SS+5 days	No										
926	LANTAI 14	321 days	Fri 3/2/18	Wed 1/16/19	855SS+5 days	No										
997	LANTAI 15	321 days	Wed 3/7/18	Mon 1/21/19	926SS+5 days	No										
1068	LANTAI 16	321 days	Mon 3/12/18	Sat 1/26/19	997SS+5 days	No										
1139	LANTAI 17	321 days	Sat 3/17/18	Thu 1/31/19	1068SS+5 days	No										
1210	LANTAI 18	321 days	Thu 3/22/18	Tue 2/5/19	1139SS+5 days	No										
1281	LANTAI 18A	321 days	Tue 3/27/18	Sun 2/10/19	1210SS+5 days	No										
1352	LANTAI 19	321 days	Sun 4/1/18	Fri 2/15/19	1281SS+5 days	No										
1423	LANTAI 19A	321 days	Fri 4/6/18	Wed 2/20/19	1352SS+5 days	No										
1494	LANTAI 20	321 days	Wed 4/11/18	Mon 2/25/19	1423SS+5 days	No										
1565	LANTAI 21	321 days	Mon 4/16/18	Sat 3/2/19	1494SS+5 days	Yes										
1566	AREA UNIT	285 days	Mon 4/16/18	Fri 1/25/19		Yes										

ID	Task Name	Duration	Start	Finish	Predecessors	Critical	2017		2018				2019			
							Q1	Q2	Q3	Q4	Q1	Q2	Q3	Q4	Q1	Q2
1567	MARKING	15 days	Mon 4/16/18	Mon 4/30/18		Yes										
1568	PEKERJAAN DINDING	270 days	Tue 5/1/18	Fri 1/25/19		Yes										
1569	PASANG BATA	30 days	Tue 5/1/18	Wed 5/30/18	1567	Yes										
1570	PLESTER/RENDER	30 days	Sat 6/30/18	Sun 7/29/18	1569,1573,1574,15	No										
1571	CAT DINDING	30 days	Mon 7/30/18	Tue 8/28/18	1570	No										
1572	MEP DINDING	240 days	Thu 5/31/18	Fri 1/25/19		No										
1573	ELEKTRONIK	30 days	Thu 5/31/18	Fri 6/29/18	1569	No										
1574	ELEKTRIKAL	30 days	Thu 5/31/18	Fri 6/29/18	1569	No										
1575	MVAC	30 days	Thu 5/31/18	Fri 6/29/18	1569	No										
1576	FIXTURES MEP DALAM DINDING	30 days	Thu 12/27/18	Fri 1/25/19	1573,1574,1575,15	No										
1577	TEST MEP	30 days	Sat 6/30/18	Sun 7/29/18	1573,1574,1575	No										
1578	PINTU KAYU	60 days	Sun 10/28/18	Wed 12/26/18		No										
1579	KUSEN PINTU	30 days	Sun 10/28/18	Mon 11/26/18	1570,1583	No										
1580	DAUN PINTU	30 days	Sun 10/28/18	Mon 11/26/18	1571FF,1579SS	No										
1581	ACESSORIES	30 days	Tue 11/27/18	Wed 12/26/18	1580	No										
1582	PEKERJAAN LANTAI	44 days	Fri 9/28/18	Sat 11/10/18		No										
1583	PASANG MARBEL	30 days	Fri 9/28/18	Sat 10/27/18	1587	No										
1584	POLES MARBEL	30 days	Fri 10/12/18	Sat 11/10/18	1583SS+14 days	No										
1585	PEKERJAAN PLAFOND	240 days	Thu 5/31/18	Fri 1/25/19		No										
1586	PASANG RANGKA	30 days	Mon 7/30/18	Tue 8/28/18	1570,1591,1594	No										
1587	TUTUP PLAFOND	30 days	Wed 8/29/18	Thu 9/27/18	1586,1596	No										
1588	COMPOUND	30 days	Fri 9/28/18	Sat 10/27/18	1587	No										
1589	CAT PLAFOND	30 days	Sun 10/28/18	Mon 11/26/18	1588	No										
1590	MEP DALAM PLAFOND	240 days	Thu 5/31/18	Fri 1/25/19		No										
1591	ELEKTRIKAL	30 days	Thu 5/31/18	Fri 6/29/18	1569,1574SS	No										

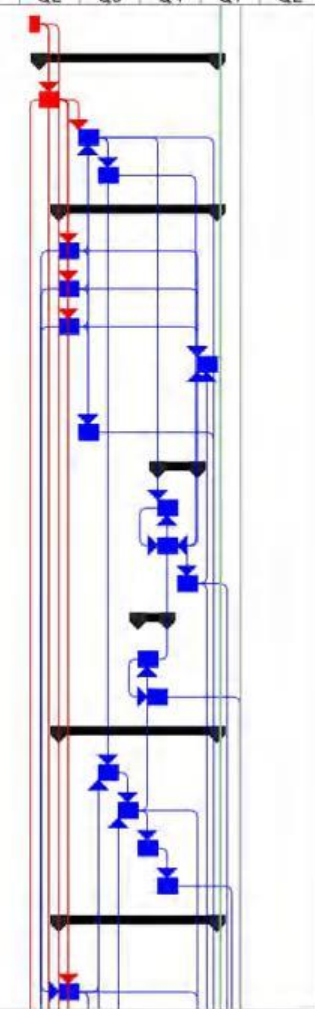

ID	Task Name	Duration	Start	Finish	Predecessors	Critical	2017		2018		2019	
							Q1	Q2	Q3	Q4	Q1	Q2
1592	ELEKTRONIK	30 days	Thu 5/31/18	Fri 6/29/18	1569,1573SS	No						
1593	MVAC	30 days	Thu 5/31/18	Fri 6/29/18	1569,1575SS	No						
1594	PLPK	30 days	Thu 5/31/18	Fri 6/29/18	1569	No						
1595	FIXTURE MEP DALAM PLAFOND	30 days	Thu 12/27/18	Fri 1/25/19	1581,1587,1591,1595	No						
1596	TEST MEP	30 days	Sat 6/30/18	Sun 7/29/18	1591,1592,1593,1595	No						
1597	AREA KAMAR MANDI	275 days	Thu 5/31/18	Fri 3/1/19		Yes						
1598	CORING	20 days	Thu 5/31/18	Tue 6/19/18	1569	Yes						
1599	PASANG PIPA	25 days	Wed 6/20/18	Sat 7/14/18	1598	Yes						
1600	TEST BOCOR	20 days	Sun 7/15/18	Fri 8/3/18	1599	Yes						
1601	GROUTING	25 days	Sat 8/4/18	Tue 8/28/18	1600	Yes						
1602	PASANG HT DINDING	25 days	Sat 10/13/18	Tue 11/6/18	1569SS,1600,1604	Yes						
1603	WATER PROOFING	25 days	Wed 8/29/18	Sat 9/22/18	1601	Yes						
1604	TEST WATER PROOFING	20 days	Sun 9/23/18	Fri 10/12/18	1603	Yes						
1605	PASANG HT LANTAI	25 days	Thu 12/27/18	Sun 1/20/19	1602,1604,1607	Yes						
1606	PASANG RANGKA PLAFOND	25 days	Wed 11/7/18	Sat 12/1/18	1602	Yes						
1607	TUTUP PLAFOND	25 days	Sun 12/2/18	Wed 12/26/18	1606	Yes						
1608	CAT PLAFOND	25 days	Thu 12/27/18	Sun 1/20/19	1589FF,1607	No						
1609	PASANG PINTU	20 days	Mon 1/21/19	Sat 2/9/19	1570,1577,1605	Yes						
1610	PASANG SANITARY	20 days	Sun 2/10/19	Fri 3/1/19	1581,1609	Yes						
1611	AREA FAÇADE/BALKON	125 days	Tue 5/1/18	Sun 9/2/18		No						
1612	PASANG PC PANEL	25 days	Tue 5/1/18	Fri 5/25/18	1567	No						
1613	PASANG JENDELA ALUMINIUM	25 days	Sat 5/26/18	Tue 6/19/18	1612	No						
1614	PASANG RAILING BALKON	30 days	Sat 5/26/18	Sun 6/24/18	1612	No						

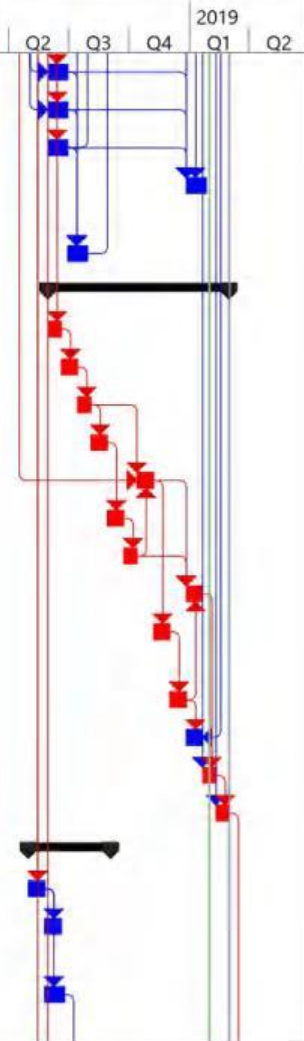

ID	Task Name	Duration	Start	Finish	Predecessors	Critical	2017		2018				2019			
							Q1	Q2	Q3	Q4	Q1	Q2	Q3	Q4	Q1	Q2
1615	PASANG HT LANTAI	25 days	Thu 8/9/18	Sun 9/2/18	1617	No										
1616	WATER PROOFING	25 days	Mon 6/25/18	Thu 7/19/18	1614	No										
1617	TEST WATER PROOFING	20 days	Fri 7/20/18	Wed 8/8/18	1616	No										
1618	AREA CORIDOR	245.5 days	Tue 5/1/18	Tue 1/1/19		No										
1619	Pasang Bata	25 days	Thu 5/31/18	Sun 6/24/18	1567FS+30 days	No										
1620	Pasang Conduit + Inbodus di Dinding	25 days	Tue 6/12/18	Sat 7/7/18	1619SS+50%	No										
1621	Pasang Conduit di Plafond	25 days	Tue 6/12/18	Sat 7/7/18	1620SS	No										
1622	Render/Plaster	25 days	Mon 6/25/18	Thu 7/19/18	1620SS+50%	No										
1623	Instalasi Kabel	25 days	Sun 6/17/18	Thu 7/12/18	1621SS+5 days	No										
1624	Instalasi MVAC	25 days	Sun 6/17/18	Thu 7/12/18	1621SS+5 days	No										
1625	Pipa Fire Fighting	25 days	Tue 5/1/18	Fri 5/25/18	1567	No										
1626	Test Parsial MEP dalam Plafond	20 days	Mon 8/6/18	Sun 8/26/18	1627	No										
1627	Rangka Plafond	25 days	Thu 7/12/18	Mon 8/6/18	1623,1624,1625	No										
1628	Tutup Plafond	25 days	Wed 8/29/18	Sun 9/23/18	1626FS+3 days	No										
1629	Pasang HT/Keramik	25 days	Sun 9/23/18	Thu 10/18/18	1628	No										
1630	Railing Tangga	25 days	Mon 6/25/18	Thu 7/19/18	1619	No										
1631	ME Fixture di Plafond	25 days	Mon 11/12/18	Fri 12/7/18	1628,1633	No										
1632	ME Fixture di Dinding	25 days	Mon 11/12/18	Fri 12/7/18	1631SS,1633	No										
1633	Pintu Besi	25 days	Thu 10/18/18	Mon 11/12/18	1629	No										
1634	Pengecatan	25 days	Fri 12/7/18	Tue 1/1/19	1622,1628,1629,1631	No										
1635	Finish Lantai 21	1 day	Sat 3/2/19	Sat 3/2/19	1584,1610,1617,1634	Yes										

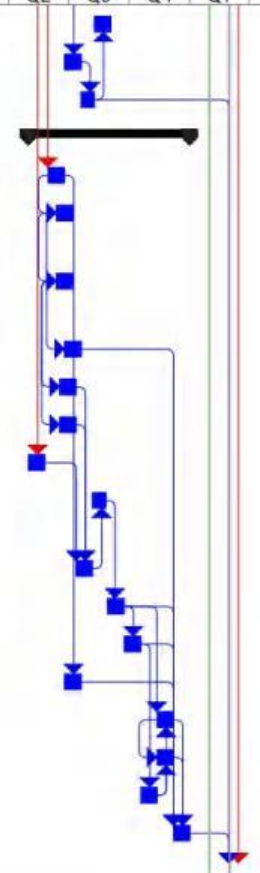

Lampiran 25. Daftar Aktivitas, *Network Planning*, Predecessor Lantai 23

PEMILIK		COMPOSITE SCHEDULE					KONSULTAN MK									
PODO MORO CITY DELI MEGAH		FINISHING-ME TOWER 3L					JAYA CM									
ID	Task Name	Duration	Start	Finish	Predecessors	Critical	2017				2018				2019	
							Q1	Q2	Q3	Q4	Q1	Q2	Q3	Q4	Q1	Q2
1	SCHEDULE FINISHING-ME TOWER 3L	431 days	Mon 1/1/18	Thu 3/7/19		Yes										
2	LINCOLN (Lantai LM)	431 days	Mon 1/1/18	Thu 3/7/19		Yes										
3	LANTAI 1	321 days	Mon 1/1/18	Sat 11/17/18		No										
74	LANTAI 2	321 days	Sat 1/6/18	Thu 11/22/18	3SS+5 days	No										
145	LANTAI 3	321 days	Thu 1/11/18	Tue 11/27/18	74SS+5 days	No										
216	LANTAI 5	321 days	Tue 1/16/18	Sun 12/2/18	145SS+5 days	No										
287	LANTAI 6	321 days	Sun 1/21/18	Fri 12/7/18	216SS+5 days	No										
358	LANTAI 7	321 days	Fri 1/26/18	Wed 12/12/18	287SS+5 days	No										
429	LANTAI 8	321 days	Wed 1/31/18	Mon 12/17/18	358SS+5 days	No										
500	LANTAI 9	321 days	Mon 2/5/18	Sat 12/22/18	429SS+5 days	No										
571	LANTAI 10	321 days	Sat 2/10/18	Thu 12/27/18	500SS+5 days	No										
642	LANTAI 11	321 days	Thu 2/15/18	Tue 1/1/19	571SS+5 days	No										
713	LANTAI 11	321 days	Thu 2/15/18	Tue 1/1/19	571SS+5 days	No										
784	LANTAI 12	321 days	Tue 2/20/18	Sun 1/6/19	713SS+5 days	No										
855	LANTAI 13	321 days	Sun 2/25/18	Fri 1/11/19	784SS+5 days	No										
926	LANTAI 14	321 days	Fri 3/2/18	Wed 1/16/19	855SS+5 days	No										
997	LANTAI 15	321 days	Wed 3/7/18	Mon 1/21/19	926SS+5 days	No										
1068	LANTAI 16	321 days	Mon 3/12/18	Sat 1/26/19	997SS+5 days	No										
1139	LANTAI 17	321 days	Sat 3/17/18	Thu 1/31/19	1068SS+5 days	No										
1210	LANTAI 18	321 days	Thu 3/22/18	Tue 2/5/19	1139SS+5 days	No										
1281	LANTAI 18A	321 days	Tue 3/27/18	Sun 2/10/19	1210SS+5 days	No										
1352	LANTAI 19	321 days	Sun 4/1/18	Fri 2/15/19	1281SS+5 days	No										
1423	LANTAI 19A	321 days	Fri 4/6/18	Wed 2/20/19	1352SS+5 days	No										
1494	LANTAI 20	321 days	Wed 4/11/18	Mon 2/25/19	1423SS+5 days	No										
1565	LANTAI 21	321 days	Mon 4/16/18	Sat 3/2/19	1494SS+5 days	No										
1636	LANTAI 23	321 days	Sat 4/21/18	Thu 3/7/19	1565SS+5 days	Yes										

ID	Task Name	Duration	Start	Finish	Predecessors	Critical	2017		2018				2019			
							Q1	Q2	Q3	Q4	Q1	Q2	Q3	Q4	Q1	Q2
1637	AREA UNIT	285 days	Sat 4/21/18	Wed 1/30/19		Yes										
1638	MARKING	15 days	Sat 4/21/18	Sat 5/5/18		Yes										
1639	PEKERJAAN DINDING	270 days	Sun 5/6/18	Wed 1/30/19		Yes										
1640	PASANG BATA	30 days	Sun 5/6/18	Mon 6/4/18	1638	Yes										
1641	PLESTER/RENDER	30 days	Thu 7/5/18	Fri 8/3/18	1640,1644,1645,16	No										
1642	CAT DINDING	30 days	Sat 8/4/18	Sun 9/2/18	1641	No										
1643	MEP DINDING	240 days	Tue 6/5/18	Wed 1/30/19		No										
1644	ELEKTRONIK	30 days	Tue 6/5/18	Wed 7/4/18	1640	No										
1645	ELEKTRIKAL	30 days	Tue 6/5/18	Wed 7/4/18	1640	No										
1646	MVAC	30 days	Tue 6/5/18	Wed 7/4/18	1640	No										
1647	FIXTURES MEP DALAM DINDING	30 days	Tue 1/1/19	Wed 1/30/19	1644,1645,1646,16	No										
1648	TEST MEP	30 days	Thu 7/5/18	Fri 8/3/18	1644,1645,1646	No										
1649	PINTU KAYU	60 days	Fri 11/2/18	Mon 12/31/18		No										
1650	KUSEN PINTU	30 days	Fri 11/2/18	Sat 12/1/18	1641,1654	No										
1651	DAUN PINTU	30 days	Fri 11/2/18	Sat 12/1/18	1642FF,1650SS	No										
1652	ACESSORIES	30 days	Sun 12/2/18	Mon 12/31/18	1651	No										
1653	PEKERJAAN LANTAI	44 days	Wed 10/3/18	Thu 11/15/18		No										
1654	PASANG MARBEL	30 days	Wed 10/3/18	Thu 11/1/18	1658	No										
1655	POLES MARBEL	30 days	Wed 10/17/18	Thu 11/15/18	1654SS+14 days	No										
1656	PEKERJAAN PLAFOND	240 days	Tue 6/5/18	Wed 1/30/19		No										
1657	PASANG RANGKA	30 days	Sat 8/4/18	Sun 9/2/18	1641,1662,1665	No										
1658	TUTUP PLAFOND	30 days	Mon 9/3/18	Tue 10/2/18	1657,1667	No										
1659	COMPOUND	30 days	Wed 10/3/18	Thu 11/1/18	1658	No										
1660	CAT PLAFOND	30 days	Fri 11/2/18	Sat 12/1/18	1659	No										
1661	MEP DALAM PLAFOND	240 days	Tue 6/5/18	Wed 1/30/19		No										

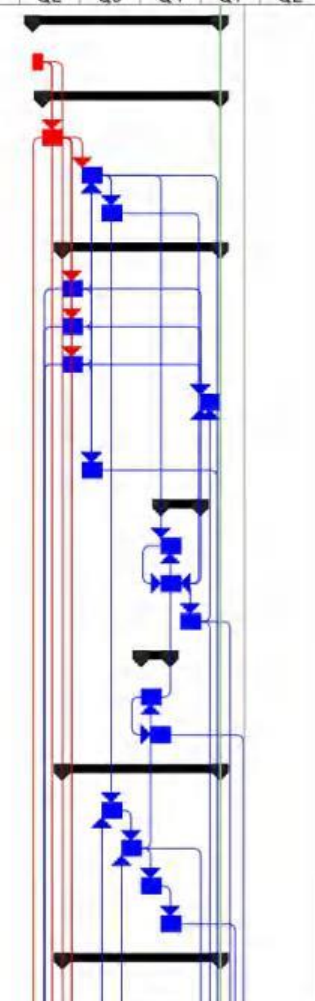

ID	Task Name	Duration	Start	Finish	Predecessors	Critical	2017		2018				2019					
							Q1	Q2	Q3	Q4	Q1	Q2	Q3	Q4	Q1	Q2		
1662	ELEKTRIKAL	30 days	Tue 6/5/18	Wed 7/4/18	1640,1645SS	No												
1663	ELEKTRONIK	30 days	Tue 6/5/18	Wed 7/4/18	1640,1644SS	No												
1664	MVAC	30 days	Tue 6/5/18	Wed 7/4/18	1640,1646SS	No												
1665	PLPK	30 days	Tue 6/5/18	Wed 7/4/18	1640	No												
1666	FIXTURE MEP DALAM PLAFOND	30 days	Tue 1/1/19	Wed 1/30/19	1652,1658,1662,1664	No												
1667	TEST MEP	30 days	Thu 7/5/18	Fri 8/3/18	1662,1663,1664,1666	No												
1668	AREA KAMAR MANDI	275 days	Tue 6/5/18	Wed 3/6/19		Yes												
1669	CORING	20 days	Tue 6/5/18	Sun 6/24/18	1640	Yes												
1670	PASANG PIPA	25 days	Mon 6/25/18	Thu 7/19/18	1669	Yes												
1671	TEST BOCOR	20 days	Fri 7/20/18	Wed 8/8/18	1670	Yes												
1672	GROUTING	25 days	Thu 8/9/18	Sun 9/2/18	1671	Yes												
1673	PASANG HT DINDING	25 days	Thu 10/18/18	Sun 11/11/18	1640SS,1671,1675	Yes												
1674	WATER PROOFING	25 days	Mon 9/3/18	Thu 9/27/18	1672	Yes												
1675	TEST WATER PROOFING	20 days	Fri 9/28/18	Wed 10/17/18	1674	Yes												
1676	PASANG HT LANTAI	25 days	Tue 1/1/19	Fri 1/25/19	1673,1675,1678	Yes												
1677	PASANG RANGKA PLAFOND	25 days	Mon 11/12/18	Thu 12/6/18	1673	Yes												
1678	TUTUP PLAFOND	25 days	Fri 12/7/18	Mon 12/31/18	1677	Yes												
1679	CAT PLAFOND	25 days	Tue 1/1/19	Fri 1/25/19	1660FF,1678	No												
1680	PASANG PINTU	20 days	Sat 1/26/19	Thu 2/14/19	1641,1648,1676	Yes												
1681	PASANG SANITARY	20 days	Fri 2/15/19	Wed 3/6/19	1652,1680	Yes												
1682	AREA FAÇADE/BALKON	125 days	Sun 5/6/18	Fri 9/7/18		No												
1683	PASANG PC PANEL	25 days	Sun 5/6/18	Wed 5/30/18	1638	No												
1684	PASANG JENDELA ALUMUNIUM	25 days	Thu 5/31/18	Sun 6/24/18	1683	No												

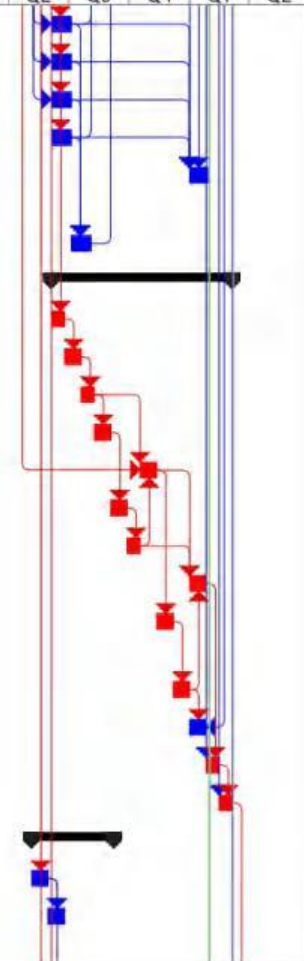

ID	Task Name	Duration	Start	Finish	Predecessors	Critical	2017		2018				2019			
							Q1	Q2	Q3	Q4	Q1	Q2	Q3	Q4	Q1	Q2
1685	PASANG RAILING BALKON	30 days	Thu 5/31/18	Fri 6/29/18	1683	No										
1686	PASANG HT LANTAI	25 days	Tue 8/14/18	Fri 9/7/18	1688	No										
1687	WATER PROOFING	25 days	Sat 6/30/18	Tue 7/24/18	1685	No										
1688	TEST WATER PROOFING	20 days	Wed 7/25/18	Mon 8/13/18	1687	No										
1689	AREA CORIDOR	245.5 days	Sun 5/6/18	Sun 1/6/19		No										
1690	Pasang Bata	25 days	Tue 6/5/18	Fri 6/29/18	1638FS+30 days	No										
1691	Pasang Conduit + Inbodus di Dinding	25 days	Sun 6/17/18	Thu 7/12/18	1690SS+50%	No										
1692	Pasang Conduit di Plafond	25 days	Sun 6/17/18	Thu 7/12/18	1691SS	No										
1693	Render/Plaster	25 days	Sat 6/30/18	Tue 7/24/18	1691SS+50%	No										
1694	Instalasi Kabel	25 days	Fri 6/22/18	Tue 7/17/18	1692SS+5 days	No										
1695	Instalasi MVAC	25 days	Fri 6/22/18	Tue 7/17/18	1692SS+5 days	No										
1696	Pipa Fire Fighting	25 days	Sun 5/6/18	Wed 5/30/18	1638	No										
1697	Test Parsial MEP dalam Plafond	20 days	Sat 8/11/18	Fri 8/31/18	1698	No										
1698	Rangka Plafond	25 days	Tue 7/17/18	Sat 8/11/18	1694,1695,1696	No										
1699	Tutup Plafond	25 days	Mon 9/3/18	Fri 9/28/18	1697FS+3 days	No										
1700	Pasang HT/Keramik	25 days	Fri 9/28/18	Tue 10/23/18	1699	No										
1701	Railing Tangga	25 days	Sat 6/30/18	Tue 7/24/18	1690	No										
1702	ME Fixture di Plafond	25 days	Sat 11/17/18	Wed 12/12/18	1699,1704	No										
1703	ME Fixture di Dinding	25 days	Sat 11/17/18	Wed 12/12/18	1702SS,1704	No										
1704	Pintu Besi	25 days	Tue 10/23/18	Sat 11/17/18	1700	No										
1705	Pengecatan	25 days	Wed 12/12/18	Sun 1/6/19	1693,1699,1700,1704	No										
1706	Finish Lantai 23	1 day	Thu 3/7/19	Thu 3/7/19	1655,1681,1688,1705	Yes										

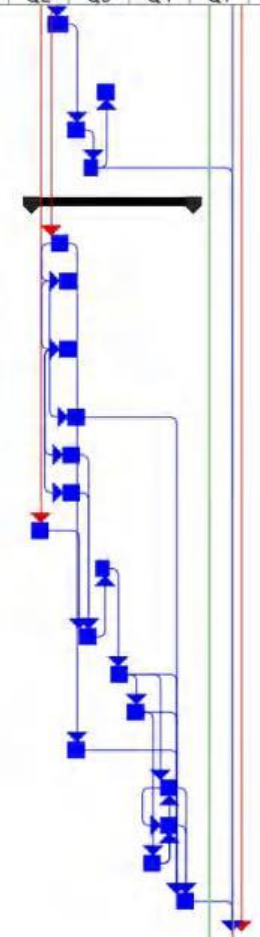

Lampiran 26. Daftar Aktivitas, *Network Planning, Predecessor* Lantai 25

PEMILIK		COMPOSITE SCHEDULE					KONSULTAN MK									
PODO MORO CITY		FINISHING-ME TOWER 3L					JAYA CM									
ID	Task Name	Duration	Start	Finish	Predecessors	Critical	2017				2018				2019	
							Q1	Q2	Q3	Q4	Q1	Q2	Q3	Q4	Q1	Q2
1	SCHEDULE FINISHING-ME TOWER 3L	436 days	Mon 1/1/18	Tue 3/12/19		Yes										
2	LINCOLN (Lantai LM)	436 days	Mon 1/1/18	Tue 3/12/19		Yes										
3	LANTAI 1	321 days	Mon 1/1/18	Sat 11/17/18		No										
74	LANTAI 2	321 days	Sat 1/6/18	Thu 11/22/18	3SS+5 days	No										
145	LANTAI 3	321 days	Thu 1/11/18	Tue 11/27/18	74SS+5 days	No										
216	LANTAI 5	321 days	Tue 1/16/18	Sun 12/2/18	145SS+5 days	No										
287	LANTAI 6	321 days	Sun 1/21/18	Fri 12/7/18	216SS+5 days	No										
358	LANTAI 7	321 days	Fri 1/26/18	Wed 12/12/18	287SS+5 days	No										
429	LANTAI 8	321 days	Wed 1/31/18	Mon 12/17/18	358SS+5 days	No										
500	LANTAI 9	321 days	Mon 2/5/18	Sat 12/22/18	429SS+5 days	No										
571	LANTAI 10	321 days	Sat 2/10/18	Thu 12/27/18	500SS+5 days	No										
642	LANTAI 11	321 days	Thu 2/15/18	Tue 1/1/19	571SS+5 days	No										
713	LANTAI 11	321 days	Thu 2/15/18	Tue 1/1/19	571SS+5 days	No										
784	LANTAI 12	321 days	Tue 2/20/18	Sun 1/6/19	713SS+5 days	No										
855	LANTAI 13	321 days	Sun 2/25/18	Fri 1/11/19	784SS+5 days	No										
926	LANTAI 14	321 days	Fri 3/2/18	Wed 1/16/19	855SS+5 days	No										
997	LANTAI 15	321 days	Wed 3/7/18	Mon 1/21/19	926SS+5 days	No										
1068	LANTAI 16	321 days	Mon 3/12/18	Sat 1/26/19	997SS+5 days	No										
1139	LANTAI 17	321 days	Sat 3/17/18	Thu 1/31/19	1068SS+5 days	No										
1210	LANTAI 18	321 days	Thu 3/22/18	Tue 2/5/19	1139SS+5 days	No										
1281	LANTAI 18A	321 days	Tue 3/27/18	Sun 2/10/19	1210SS+5 days	No										
1352	LANTAI 19	321 days	Sun 4/1/18	Fri 2/15/19	1281SS+5 days	No										
1423	LANTAI 19A	321 days	Fri 4/6/18	Wed 2/20/19	1352SS+5 days	No										
1494	LANTAI 20	321 days	Wed 4/11/18	Mon 2/25/19	1423SS+5 days	No										
1565	LANTAI 21	321 days	Mon 4/16/18	Sat 3/2/19	1494SS+5 days	No										
1636	LANTAI 23	321 days	Sat 4/21/18	Thu 3/7/19	1565SS+5 days	No										

ID	Task Name	Duration	Start	Finish	Predecessors	Critical	2017		2018				2019			
							Q1	Q2	Q3	Q4	Q1	Q2	Q3	Q4	Q1	Q2
1707	LANTAI 25	321 days	Thu 4/26/18	Tue 3/12/19	1636SS+5 days	Yes										
1708	AREA UNIT	285 days	Thu 4/26/18	Mon 2/4/19		Yes										
1709	MARKING	15 days	Thu 4/26/18	Thu 5/10/18		Yes										
1710	PEKERJAAN DINDING	270 days	Fri 5/11/18	Mon 2/4/19		Yes										
1711	PASANG BATA	30 days	Fri 5/11/18	Sat 6/9/18	1709	Yes										
1712	PLESTER/RENDER	30 days	Tue 7/10/18	Wed 8/8/18	1711,1715,1716,17	No										
1713	CAT DINDING	30 days	Thu 8/9/18	Fri 9/7/18	1712	No										
1714	MEP DINDING	240 days	Sun 6/10/18	Mon 2/4/19		No										
1715	ELEKTRONIK	30 days	Sun 6/10/18	Mon 7/9/18	1711	No										
1716	ELEKTRIKAL	30 days	Sun 6/10/18	Mon 7/9/18	1711	No										
1717	MVAC	30 days	Sun 6/10/18	Mon 7/9/18	1711	No										
1718	FIXTURES MEP DALAM DINDING	30 days	Sun 1/6/19	Mon 2/4/19	1715,1716,1717,17	No										
1719	TEST MEP	30 days	Tue 7/10/18	Wed 8/8/18	1715,1716,1717	No										
1720	PINTU KAYU	60 days	Wed 11/7/18	Sat 1/5/19		No										
1721	KUSEN PINTU	30 days	Wed 11/7/18	Thu 12/6/18	1712,1725	No										
1722	DAUN PINTU	30 days	Wed 11/7/18	Thu 12/6/18	1713FF,1721SS	No										
1723	ACESSORIES	30 days	Fri 12/7/18	Sat 1/5/19	1722	No										
1724	PEKERJAAN LANTAI	44 days	Mon 10/8/18	Tue 11/20/18		No										
1725	PASANG MARBEL	30 days	Mon 10/8/18	Tue 11/6/18	1729	No										
1726	POLES MARBEL	30 days	Mon 10/22/18	Tue 11/20/18	1725SS+14 days	No										
1727	PEKERJAAN PLAFOND	240 days	Sun 6/10/18	Mon 2/4/19		No										
1728	PASANG RANGKA	30 days	Thu 8/9/18	Fri 9/7/18	1712,1733,1736	No										
1729	TUTUP PLAFOND	30 days	Sat 9/8/18	Sun 10/7/18	1728,1738	No										
1730	COMPOUND	30 days	Mon 10/8/18	Tue 11/6/18	1729	No										
1731	CAT PLAFOND	30 days	Wed 11/7/18	Thu 12/6/18	1730	No										

ID	Task Name	Duration	Start	Finish	Predecessors	Critical	2017		2018		2019	
							Q1	Q2	Q3	Q4	Q1	Q2
1732	MEP DALAM PLAFOND	240 days	Sun 6/10/18	Mon 2/4/19		No						
1733	ELEKTRIKAL	30 days	Sun 6/10/18	Mon 7/9/18	1711,1716SS	No						
1734	ELEKTRONIK	30 days	Sun 6/10/18	Mon 7/9/18	1711,1715SS	No						
1735	MVAC	30 days	Sun 6/10/18	Mon 7/9/18	1711,1717SS	No						
1736	PLPK	30 days	Sun 6/10/18	Mon 7/9/18	1711	No						
1737	FIXTURE MEP DALAM PLAFOND	30 days	Sun 1/6/19	Mon 2/4/19	1723,1729,1733,17	No						
1738	TEST MEP	30 days	Tue 7/10/18	Wed 8/8/18	1733,1734,1735,17	No						
1739	AREA KAMAR MANDI	275 days	Sun 6/10/18	Mon 3/11/19		Yes						
1740	CORING	20 days	Sun 6/10/18	Fri 6/29/18	1711	Yes						
1741	PASANG PIPA	25 days	Sat 6/30/18	Tue 7/24/18	1740	Yes						
1742	TEST BOCOR	20 days	Wed 7/25/18	Mon 8/13/18	1741	Yes						
1743	GROUTING	25 days	Tue 8/14/18	Fri 9/7/18	1742	Yes						
1744	PASANG HT DINDING	25 days	Tue 10/23/18	Fri 11/16/18	1711SS,1742,1746	Yes						
1745	WATER PROOFING	25 days	Sat 9/8/18	Tue 10/2/18	1743	Yes						
1746	TEST WATER PROOFING	20 days	Wed 10/3/18	Mon 10/22/18	1745	Yes						
1747	PASANG HT LANTAI	25 days	Sun 1/6/19	Wed 1/30/19	1744,1746,1749	Yes						
1748	PASANG RANGKA PLAFOND	25 days	Sat 11/17/18	Tue 12/11/18	1744	Yes						
1749	TUTUP PLAFOND	25 days	Wed 12/12/18	Sat 1/5/19	1748	Yes						
1750	CAT PLAFOND	25 days	Sun 1/6/19	Wed 1/30/19	1731FF,1749	No						
1751	PASANG PINTU	20 days	Thu 1/31/19	Tue 2/19/19	1712,1719,1747	Yes						
1752	PASANG SANITARY	20 days	Wed 2/20/19	Mon 3/11/19	1723,1751	Yes						
1753	AREA FAÇADE/BALKON	125 days	Fri 5/11/18	Wed 9/12/18		No						
1754	PASANG PC PANEL	25 days	Fri 5/11/18	Mon 6/4/18	1709	No						

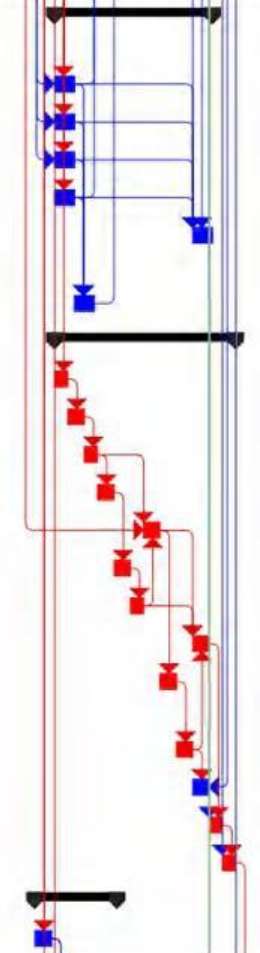

ID	Task Name	Duration	Start	Finish	Predecessors	Critical	2017		2018				2019			
							Q1	Q2	Q3	Q4	Q1	Q2	Q3	Q4	Q1	Q2
1755	PASANG JENDELA ALUMUNIU	25 days	Tue 6/5/18	Fri 6/29/18	1754	No										
1756	PASANG RAILING BALKON	30 days	Tue 6/5/18	Wed 7/4/18	1754	No										
1757	PASANG HT LANTAI	25 days	Sun 8/19/18	Wed 9/12/18	1759	No										
1758	WATER PROOFING	25 days	Thu 7/5/18	Sun 7/29/18	1756	No										
1759	TEST WATER PROOFING	20 days	Mon 7/30/18	Sat 8/18/18	1758	No										
1760	AREA CORIDOR	245.5 days	Fri 5/11/18	Fri 1/11/19		No										
1761	Pasang Bata	25 days	Sun 6/10/18	Wed 7/4/18	1709FS+30 days	No										
1762	Pasang Conduit + Inbodus di Dinding	25 days	Fri 6/22/18	Tue 7/17/18	1761SS+50%	No										
1763	Pasang Conduit di Plafond	25 days	Fri 6/22/18	Tue 7/17/18	1762SS	No										
1764	Render/Plaster	25 days	Thu 7/5/18	Sun 7/29/18	1762SS+50%	No										
1765	Instalasi Kabel	25 days	Wed 6/27/18	Sun 7/22/18	1763SS+5 days	No										
1766	Instalasi MVAC	25 days	Wed 6/27/18	Sun 7/22/18	1763SS+5 days	No										
1767	Pipa Fire Fighting	25 days	Fri 5/11/18	Mon 6/4/18	1709	No										
1768	Test Parsial MEP dalam Plafond	20 days	Thu 8/16/18	Wed 9/5/18	1769	No										
1769	Rangka Plafond	25 days	Sun 7/22/18	Thu 8/16/18	1765,1766,1767	No										
1770	Tutup Plafond	25 days	Sat 9/8/18	Wed 10/3/18	1768FS+3 days	No										
1771	Pasang HT/Keramik	25 days	Wed 10/3/18	Sun 10/28/18	1770	No										
1772	Railing Tangga	25 days	Thu 7/5/18	Sun 7/29/18	1761	No										
1773	ME Fixture di Plafond	25 days	Thu 11/22/18	Mon 12/17/18	1770,1775	No										
1774	ME Fixture di Dinding	25 days	Thu 11/22/18	Mon 12/17/18	1773SS,1775	No										
1775	Pintu Besi	25 days	Sun 10/28/18	Thu 11/22/18	1771	No										
1776	Pengecatan	25 days	Mon 12/17/18	Fri 1/11/19	1764,1770,1771,17	No										

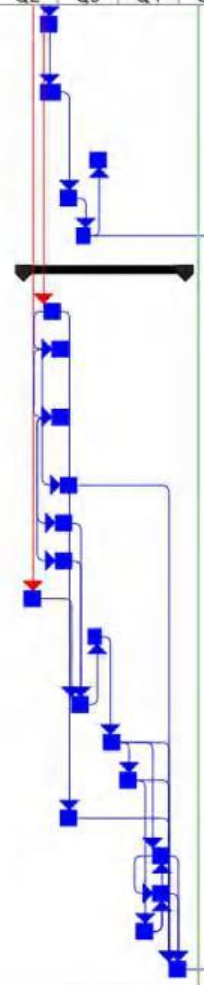

ID	Task Name	Duration	Start	Finish	Predecessors	Critical	2017				2018				2019			
							Q1	Q2	Q3	Q4	Q1	Q2	Q3	Q4	Q1	Q2		
1777	Finish Lantai 25	1 day	Tue 3/12/19	Tue 3/12/19	1726,1752,1759,17	Yes												

Lampiran 27. Daftar Aktivitas, *Network Planning, Predecessor* Lantai 26

PEMILIK		COMPOSITE SCHEDULE					KONSULTAN MK									
PODO MORO CITY DELI MEGAN		FINISHING-ME TOWER 3L					JAYA CM									
ID	Task Name	Duration	Start	Finish	Predecessors	Critical	2017				2018				2019	
							Q1	Q2	Q3	Q4	Q1	Q2	Q3	Q4	Q1	Q2
1	SCHEDULE FINISHING-ME TOWER 3L	441 days	Mon 1/1/18	Sun 3/17/19		Yes										
2	LINCOLN (Lantai LM)	441 days	Mon 1/1/18	Sun 3/17/19		Yes										
3	LANTAI 1	321 days	Mon 1/1/18	Sat 11/17/18		No										
74	LANTAI 2	321 days	Sat 1/6/18	Thu 11/22/18	3SS+5 days	No										
145	LANTAI 3	321 days	Thu 1/11/18	Tue 11/27/18	74SS+5 days	No										
216	LANTAI 5	321 days	Tue 1/16/18	Sun 12/2/18	145SS+5 days	No										
287	LANTAI 6	321 days	Sun 1/21/18	Fri 12/7/18	216SS+5 days	No										
358	LANTAI 7	321 days	Fri 1/26/18	Wed 12/12/18	287SS+5 days	No										
429	LANTAI 8	321 days	Wed 1/31/18	Mon 12/17/18	358SS+5 days	No										
500	LANTAI 9	321 days	Mon 2/5/18	Sat 12/22/18	429SS+5 days	No										
571	LANTAI 10	321 days	Sat 2/10/18	Thu 12/27/18	500SS+5 days	No										
642	LANTAI 11	321 days	Thu 2/15/18	Tue 1/1/19	571SS+5 days	No										
713	LANTAI 11	321 days	Thu 2/15/18	Tue 1/1/19	571SS+5 days	No										
784	LANTAI 12	321 days	Tue 2/20/18	Sun 1/6/19	713SS+5 days	No										
855	LANTAI 13	321 days	Sun 2/25/18	Fri 1/11/19	784SS+5 days	No										
926	LANTAI 14	321 days	Fri 3/2/18	Wed 1/16/19	855SS+5 days	No										
997	LANTAI 15	321 days	Wed 3/7/18	Mon 1/21/19	926SS+5 days	No										
1068	LANTAI 16	321 days	Mon 3/12/18	Sat 1/26/19	997SS+5 days	No										
1139	LANTAI 17	321 days	Sat 3/17/18	Thu 1/31/19	1068SS+5 days	No										
1210	LANTAI 18	321 days	Thu 3/22/18	Tue 2/5/19	1139SS+5 days	No										
1281	LANTAI 18A	321 days	Tue 3/27/18	Sun 2/10/19	1210SS+5 days	No										
1352	LANTAI 19	321 days	Sun 4/1/18	Fri 2/15/19	1281SS+5 days	No										
1423	LANTAI 19A	321 days	Fri 4/6/18	Wed 2/20/19	1352SS+5 days	No										
1494	LANTAI 20	321 days	Wed 4/11/18	Mon 2/25/19	1423SS+5 days	No										
1565	LANTAI 21	321 days	Mon 4/16/18	Sat 3/2/19	1494SS+5 days	No										
1636	LANTAI 23	321 days	Sat 4/21/18	Thu 3/7/19	1565SS+5 days	No										

ID	Task Name	Duration	Start	Finish	Predecessors	Critical	2017		2018				2019			
							Q1	Q2	Q3	Q4	Q1	Q2	Q3	Q4	Q1	Q2
1707	LANTAI 25	321 days	Thu 4/26/18	Tue 3/12/19	1636SS+5 days	No										
1778	LANTAI 26	321 days	Tue 5/1/18	Sun 3/17/19	1707SS+5 days	Yes										
1779	AREA UNIT	285 days	Tue 5/1/18	Sat 2/9/19		Yes										
1780	MARKING	15 days	Tue 5/1/18	Tue 5/15/18		Yes										
1781	PEKERJAAN DINDING	270 days	Wed 5/16/18	Sat 2/9/19		Yes										
1782	PASANG BATA	30 days	Wed 5/16/18	Thu 6/14/18	1780	Yes										
1783	PLESTER/RENDER	30 days	Sun 7/15/18	Mon 8/13/18	1782,1786,1787,1788	No										
1784	CAT DINDING	30 days	Tue 8/14/18	Wed 9/12/18	1783	No										
1785	MEP DINDING	240 days	Fri 6/15/18	Sat 2/9/19		No										
1786	ELEKTRONIK	30 days	Fri 6/15/18	Sat 7/14/18	1782	No										
1787	ELEKTRIKAL	30 days	Fri 6/15/18	Sat 7/14/18	1782	No										
1788	MVAC	30 days	Fri 6/15/18	Sat 7/14/18	1782	No										
1789	FIXTURES MEP DALAM DINDING	30 days	Fri 1/11/19	Sat 2/9/19	1786,1787,1788,1789	No										
1790	TEST MEP	30 days	Sun 7/15/18	Mon 8/13/18	1786,1787,1788	No										
1791	PINTU KAYU	60 days	Mon 11/12/18	Thu 1/10/19		No										
1792	KUSEN PINTU	30 days	Mon 11/12/18	Tue 12/11/18	1783,1796	No										
1793	DAUN PINTU	30 days	Mon 11/12/18	Tue 12/11/18	1784FF,1792SS	No										
1794	ACESSORIES	30 days	Wed 12/12/18	Thu 1/10/19	1793	No										
1795	PEKERJAAN LANTAI	44 days	Sat 10/13/18	Sun 11/25/18		No										
1796	PASANG MARBEL	30 days	Sat 10/13/18	Sun 11/11/18	1800	No										
1797	POLES MARBEL	30 days	Sat 10/27/18	Sun 11/25/18	1796SS+14 days	No										
1798	PEKERJAAN PLAFOND	240 days	Fri 6/15/18	Sat 2/9/19		No										
1799	PASANG RANGKA	30 days	Tue 8/14/18	Wed 9/12/18	1783,1804,1807	No										
1800	TUTUP PLAFOND	30 days	Thu 9/13/18	Fri 10/12/18	1799,1809	No										
1801	COMPOUND	30 days	Sat 10/13/18	Sun 11/11/18	1800	No										
1802	CAT PLAFOND	30 days	Mon 11/12/18	Tue 12/11/18	1801	No										

ID	Task Name	Duration	Start	Finish	Predecessors	Critical	2017		2018		2019	
							Q1	Q2	Q3	Q4	Q1	Q2
1803	MEP DALAM PLAFOND	240 days	Fri 6/15/18	Sat 2/9/19		No						
1804	ELEKTRIKAL	30 days	Fri 6/15/18	Sat 7/14/18	1782,1787SS	No						
1805	ELEKTRONIK	30 days	Fri 6/15/18	Sat 7/14/18	1782,1786SS	No						
1806	MVAC	30 days	Fri 6/15/18	Sat 7/14/18	1782,1788SS	No						
1807	PLPK	30 days	Fri 6/15/18	Sat 7/14/18	1782	No						
1808	FIXTURE MEP DALAM PLAFOND	30 days	Fri 1/11/19	Sat 2/9/19	1794,1800,1804,1808	No						
1809	TEST MEP	30 days	Sun 7/15/18	Mon 8/13/18	1804,1805,1806,1808	No						
1810	AREA KAMAR MANDI	275 days	Fri 6/15/18	Sat 3/16/19		Yes						
1811	CORING	20 days	Fri 6/15/18	Wed 7/4/18	1782	Yes						
1812	PASANG PIPA	25 days	Thu 7/5/18	Sun 7/29/18	1811	Yes						
1813	TEST BOCOR	20 days	Mon 7/30/18	Sat 8/18/18	1812	Yes						
1814	GROUTING	25 days	Sun 8/19/18	Wed 9/12/18	1813	Yes						
1815	PASANG HT DINDING	25 days	Sun 10/28/18	Wed 11/21/18	1782SS,1813,1817	Yes						
1816	WATER PROOFING	25 days	Thu 9/13/18	Sun 10/7/18	1814	Yes						
1817	TEST WATER PROOFING	20 days	Mon 10/8/18	Sat 10/27/18	1816	Yes						
1818	PASANG HT LANTAI	25 days	Fri 1/11/19	Mon 2/4/19	1815,1817,1820	Yes						
1819	PASANG RANGKA PLAFOND	25 days	Thu 11/22/18	Sun 12/16/18	1815	Yes						
1820	TUTUP PLAFOND	25 days	Mon 12/17/18	Thu 1/10/19	1819	Yes						
1821	CAT PLAFOND	25 days	Fri 1/11/19	Mon 2/4/19	1802FF,1820	No						
1822	PASANG PINTU	20 days	Tue 2/5/19	Sun 2/24/19	1783,1790,1818	Yes						
1823	PASANG SANITARY	20 days	Mon 2/25/19	Sat 3/16/19	1794,1822	Yes						
1824	AREA FAÇADE/BALKON	125 days	Wed 5/16/18	Mon 9/17/18		No						
1825	PASANG PC PANEL	25 days	Wed 5/16/18	Sat 6/9/18	1780	No						

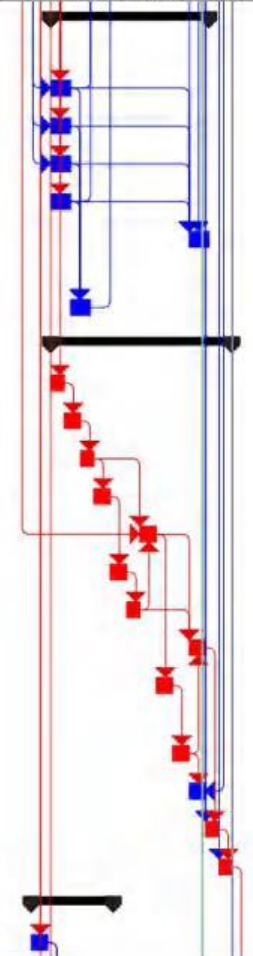

ID	Task Name	Duration	Start	Finish	Predecessors	Critical	2017		2018				2019			
							Q1	Q2	Q3	Q4	Q1	Q2	Q3	Q4	Q1	Q2
1826	PASANG JENDELA ALUMUNIUM	25 days	Sun 6/10/18	Wed 7/4/18	1825	No										
1827	PASANG RAILING BALKON	30 days	Sun 6/10/18	Mon 7/9/18	1825	No										
1828	PASANG HT LANTAI	25 days	Fri 8/24/18	Mon 9/17/18	1830	No										
1829	WATER PROOFING	25 days	Tue 7/10/18	Fri 8/3/18	1827	No										
1830	TEST WATER PROOFING	20 days	Sat 8/4/18	Thu 8/23/18	1829	No										
1831	AREA CORIDOR	245.5 days	Wed 5/16/18	Wed 1/16/19		No										
1832	Pasang Bata	25 days	Fri 6/15/18	Mon 7/9/18	1780FS+30 days	No										
1833	Pasang Conduit + Inbodus di Dinding	25 days	Wed 6/27/18	Sun 7/22/18	1832SS+50%	No										
1834	Pasang Conduit di Plafond	25 days	Wed 6/27/18	Sun 7/22/18	1833SS	No										
1835	Render/Plaster	25 days	Tue 7/10/18	Fri 8/3/18	1833SS+50%	No										
1836	Instalasi Kabel	25 days	Mon 7/2/18	Fri 7/27/18	1834SS+5 days	No										
1837	Instalasi MVAC	25 days	Mon 7/2/18	Fri 7/27/18	1834SS+5 days	No										
1838	Pipa Fire Fighting	25 days	Wed 5/16/18	Sat 6/9/18	1780	No										
1839	Test Parsial MEP dalam Plafond	20 days	Tue 8/21/18	Mon 9/10/18	1840	No										
1840	Rangka Plafond	25 days	Fri 7/27/18	Tue 8/21/18	1836,1837,1838	No										
1841	Tutup Plafond	25 days	Thu 9/13/18	Mon 10/8/18	1839FS+3 days	No										
1842	Pasang HT/Keramik	25 days	Mon 10/8/18	Fri 11/2/18	1841	No										
1843	Railing Tangga	25 days	Tue 7/10/18	Fri 8/3/18	1832	No										
1844	ME Fixture di Plafond	25 days	Tue 11/27/18	Sat 12/22/18	1841,1846	No										
1845	ME Fixture di Dinding	25 days	Tue 11/27/18	Sat 12/22/18	1844SS,1846	No										
1846	Pintu Besi	25 days	Fri 11/2/18	Tue 11/27/18	1842	No										
1847	Pengecatan	25 days	Sat 12/22/18	Wed 1/16/19	1835,1841,1842,1846	No										

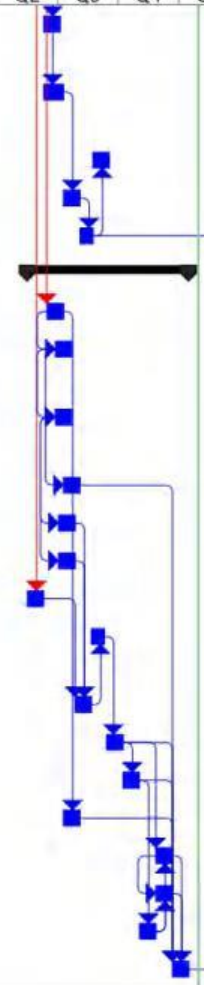

ID	Task Name	Duration	Start	Finish	Predecessors	Critical	2017				2018				2019			
							Q1	Q2	Q3	Q4	Q1	Q2	Q3	Q4	Q1	Q2		
1848	Finish Lantai 26	1 day	Sun 3/17/19	Sun 3/17/19	1797,1823,1830,18	Yes												



**CATCH UP S-CURVE PAKET PAKET PEKERJAAN MVAC (R2)
TOWER LIBERTY, LINCOLN & LEXINGTON
PROYEK PODOMORO CITY DELI MEDAN**

