

BAB V

PENUTUP

Pada bab ini menjelaskan mengenai kesimpulan dari temuan yang didapatkan dalam penelitian, implikasi manajerial, keterbatasan penelitian serta saran yang diperlukan untuk penelitian yang selanjutnya.

5.1 Kesimpulan

Berdasarkan hasil analisis data yang telah dilakukan dan dijelaskan pada bab IV, maka terdapat kesimpulan yang dapat diambil pada penelitian ini antara lain:

1. Aktivitas Pemasaran Media Sosial memengaruhi Ekuitas Merek secara signifikan. Dimana semakin tinggi aktivitas pemasaran media sosial mengenai produk Mixue di media sosial maka semakin tinggi pula ekuitas merek yang akan dirasakan oleh konsumen.
2. Ekuitas Merek memengaruhi *E-WOM* secara signifikan. Dimana ekuitas merek Mixue yang baik akan menciptakan *E-WOM* positif dari konsumen.
3. *E-WOM* mempengaruhi Niat Beli secara signifikan. Dimana semakin banyak *E-WOM* yang positif akan memengaruhi niat beli konsumen pada produk Mixue.
4. Aktivitas Pemasaran Media Sosial memengaruhi Niat Beli secara signifikan. Dimana media sosial sebagai platform komunikasi dua arah ini sangat mudah digunakan untuk bertukar informasi dan pendapat. Interaksi ini meningkatkan sikap positif terhadap merek serta memotivasi pembelian.

5.2 Implikasi Manajerial

Berdasarkan pada hasil penelitian yang telah dilakukan oleh peneliti, maka diharapkan penelitian ini dapat memberikan manfaat bagi Mixue. Berikut implikasi manajerial yang dapat diberikan dalam penelitian ini:

1. Mixue perlu cermat dalam pengenalan merek pada konsumen zaman sekarang, sehingga diharapkan pihak Mixue selalu mengawasi pihak yang ingin membuka *franchise*.
2. Ekuitas Merek memiliki pengaruh yang tinggi, maka pihak Mixue perlu mempertahankan kualitas terhadap pemilik *franchise* agar konsumen menjadikan Mixue sebagai pilihan utama dan selalu mengingat Mixue secara positif.
3. Karena *E-WOM* memiliki pengaruh yang kuat terhadap niat beli, Mixue diharapkan membuat peraturan terkait peletakan gerai Mixue, dimana antar gerai tidak boleh saling berdekatan. Dikarenakan peletakan antar gerai yang berdekatan akan dapat menimbulkan *E-WOM* negatif bahwa manajemen Mixue tidak bagus.
4. Karena Aktivitas Pemasaran Media Sosial memainkan peran penting dalam kelangsungan perusahaan, Mixue diharapkan dapat menarik konsumen untuk mengikuti instagramnya dengan memberikan konten yang menarik serta memberikan informasi yang *up to date* untuk konsumen.

5.3 Keterbatasan dan Saran Penelitian

Berdasarkan hasil penelitian yang telah dilakukan, maka terdapat beberapa keterbatasan yang telah dirangkum sebagai berikut:

1. Penelitian ini berfokus hanya pada satu situs media sosial yaitu Instagram dan tidak semua situs media sosial sehingga mungkin saja terdapat temuan yang berbeda pada media sosial lainnya.
2. Dalam penelitian ini terdapat kemungkinan responden mendapatkan informasi mengenai produk Mixue tidak hanya di media sosial Instagram.
3. Pengujian pada penelitian ini tidak secara detail menguji dimensi-dimensi sub variabelnya.
4. Dalam penelitian ini hanya menggunakan variabel Aktivitas Pemasaran Media Sosial, Ekuitas Merek, *E-WOM* sedangkan masih banyak variabel yang dapat mempengaruhi niat beli.

Berdasarkan hasil analisis pada penelitian ini. Berikut ini adalah saran peneliti bagi penelitian mendatang.

1. Penelitian selanjutnya diharapkan tidak hanya berfokus pada satu media sosial saja tetapi dapat menggunakan beberapa media sosial lainnya seperti Tiktok dan Twitter.
2. Penelitian selanjutnya diharapkan menambah pertanyaan mengenai apakah responden pernah melihat informasi mengenai produk Mixue di media sosial Instagram.
3. Penelitian selanjutnya dapat menguji hingga ke sub variabel
4. Penelitian selanjutnya diharapkan dapat menambah dan menggunakan variabel lain yang dapat mempengaruhi niat beli konsumen

DAFTAR PUSTAKA

- Aji, P. M., Nadhila, V., & Sanny, L. (2020). Effect of social media marketing on instagram towards purchase intention: Evidence from Indonesia's ready-to-drink tea industry. *International Journal of Data and Network Science*, 4(2), 91–104. <https://doi.org/10.5267/j.ijdns.2020.3.002>
- Aljaafreh, A., Mehyar, H., Saeed, M., Baroom, H., Al-Ja'afreh, A., & Al-Adaileh, R. (2020). The Impact of Electronic Word of Mouth on Consumers Purchasing Intention. *Journal of Theoretical and Applied Information Technology*. <https://www.researchgate.net/publication/338984000>
- Baker, A. M., Donthu, N., & Kumar, V. (2016). Investigating how Word-of-Mouth Conversations about Brands Influence Purchase and Retransmission Intentions. *Journal of Marketing Research*, 53(2), 225–239. <https://doi.org/10.1509/jmr.14.0099>
- Bilgin, Y. (2018). The Effect of Social Media Marketing Activities on Brand Awareness, Brand Image and Brand Loyalty. *Business & Management Studies: An International Journal*, 6(1), 128–148. <https://doi.org/10.15295/bmij.v6i1.229>
- Data Reportal. (2023). *DIGITAL 2023: INDONESIA*. <https://datareportal.com/reports/digital-2023-indonesia>
- Dewing, M. (2012). *Social media: an introduction*. Ottawa: Library of Parliament, 2012.

- Erkan, I., & Evans, C. (2018). Social media or shopping websites? The influence of eWOM on consumers' online purchase intentions. *Journal of Marketing Communications*, 24(6), 617–632.
<https://doi.org/10.1080/13527266.2016.1184706>
- Farki, A., Baihaqi, I., & Wibawa, B. M. (2016). Pengaruh Online Customer Review dan Rating Terhadap Kepercayaan dan Minat Pembelian pada Online Marketplace di Indonesia. *Jurnal Teknik ITS*, 5(2).
<https://doi.org/10.12962/j23373539.v5i2.19671>
- Garson, G. D. (2016). *Partial Least Square: Regression & Structural Equation Model*. Statistical Associates Publishing.
- Ghozali, I. (2008). *Structural Equation Model: Metode Alternatif dengan Partial Least Square (edisi 4)*. Badan Penerbit Universitas Diponegoro.
- Ghozali, I. (2018). *Aplikasi analisis multivariate dengan program IBM SPSS 25 edisi ke-9*. Universitas Diponegoro.
http://slims.umn.ac.id//index.php?p=show_detail&id=1954
- Ghozali, I., & Latan. (2015). *Partial least squares konsep, teknik dan aplikasi menggunakan program SmartPLS 3.0 untuk penelitian empiris*. Badan Penerbit Universitas Diponegoro Semarang.
- Godey, B., Manthiou, A., Pederzoli, D., Rokka, J., Aiello, G., Donvito, R., & Singh, R. (2016). Social media marketing efforts of luxury brands: Influence on brand

- equity and consumer behavior. *Journal of Business Research*, 69(12), 5833–5841. <https://doi.org/10.1016/j.jbusres.2016.04.181>
- Goyette, I., Ricard, L., Bergeron, J., & Marticotte, F. (2010). *E-WOM Scale: word-of-mouth measurement scale for e-services context*. *Canadian Journal of Administrative Sciences / Revue Canadienne Des Sciences de l'Administration*, 27(1), 5–23. <https://doi.org/10.1002/cjas.129>
- Hartono, J. (2016). *Teori Portofolio dan Analisis Investasi* (10th ed.). BPFPE.
- Husnain, M., & Toor, A. (2017). The Impact of Social Network Marketing on Consumer Purchase Intention in Pakistan: Consumer Engagement as a Mediator. *Asian Journal of Business and Accounting*, 10(1).
- Hutter, K., Hautz, J., Dennhardt, S., & Füller, J. (2013). The impact of user interactions in social media on brand awareness and purchase intention: the case of MINI on Facebook. *Journal of Product & Brand Management*, 22(5/6), 342–351. <https://doi.org/10.1108/JPBM-05-2013-0299>
- Ipsos. (2018). Instagram's Impact on Indonesian Businesses. *Ipsos*. <https://www.ipsos.com/en-id/instagrams-impact-indonesian-businesses>
- Kim, A. J., & Ko, E. (2012). Do social media marketing activities enhance customer equity? An empirical study of luxury fashion brand. *Journal of Business Research*, 65(10), 1480–1486. <https://doi.org/10.1016/j.jbusres.2011.10.014>
- Kotler, P., & Armstrong, G. (2016). *Principles of Marketing, 16th Edition*. Pearson.

- Maoyan, Zhujunxuan, & Sangyang. (2014). Consumer Purchase Intention Research Based on Social Media Marketing. *International Journal of Business and Social Science*, 5(10), 92–97. www.ijbssnet.com
- Saunders, M., Lewis, P., & Thornhill, A. (2016). *Research Methods For Business Students* (7th ed.). Pearson.
- Sekaran, U., & Bougie, R. (2017). *Metode Penelitian Untuk Bisnis : Pendekatan Pengembangan - Keahlian* (2nd ed., Vol. 2). Salemba Empat.
- Seo, E. J., & Park, J. W. (2018). A study on the effects of social media marketing activities on brand equity and customer response in the airline industry. *Journal of Air Transport Management*, 66, 36–41. <https://doi.org/10.1016/j.jairtraman.2017.09.014>
- Seo, E. J., Park, J.-W., & Choi, Y. J. (2020). The Effect of Social Media Usage Characteristics on *E-WOM*, Trust, and Brand Equity: Focusing on Users of Airline Social Media. *Sustainability*, 12(4), 1691. <https://doi.org/10.3390/su12041691>
- Sugiyono. (2014). *Metode Penelitian Pendidikan Pendekatan Kuantitatif, Kualitatif, dan R & D*. Alfabeta.
- Tiago, M. T. P. M. B., & Veríssimo, J. M. C. (2014). Digital marketing and social media: Why bother? *Business Horizons*, 57(6), 703–708. <https://doi.org/10.1016/j.bushor.2014.07.002>

Wang, Y., Ahmed, S. C., Deng, S., & Wang, H. (2019). Success of Social Media Marketing Efforts in Retaining Sustainable Online Consumers: An Empirical Analysis on the Online Fashion Retail Market. *Sustainability*, *11*(13), 3596. <https://doi.org/10.3390/su11133596>

We Are Social. (2022). DIGITAL 2022: ANOTHER YEAR OF BUMPER GROWTH. *We Are Social*. <https://wearesocial.com/uk/blog/2022/01/digital-2022-another-year-of-bumper-growth-2/>

Yadav, M., & Rahman, Z. (2017). Measuring consumer perception of social media marketing activities in e-commerce industry: Scale development & validation. *Telematics and Informatics*, *34*(7), 1294–1307. <https://doi.org/10.1016/j.tele.2017.06.001>

Yasmin, A., Tasneem, S., & Fatema, K. (2015). Effectiveness of Digital Marketing in the Challenging Age: An Empirical Study. *The International Journal of Management Science and Business Administration*, *1*(5), 69–80. <https://doi.org/10.18775/ijmsba.1849-5664-5419.2014.15.1006>

LAMPIRAN I

KUESIONER

Bagian 1 : Pertanyaan Profiling dan Pertanyaan Filter

Jenis Kelamin:

- Wanita
- Pria

Umur:

- < 24 tahun
- 24 – 35 tahun
- 35 – 44 tahun
- 45 – 54 tahun

Durasi menggunakan Instagram (dalam satu hari)

- 30 menit – 3 jam
- > 3 jam – 6 jam
- > 6 jam

Apakah anda pernah membeli produk Mixue?

- Ya
- Tidak

Apakah anda pernah mengunjungi akun Instagram Mixue?

- Ya
- Tidak

Keterangan:

1 = Sangat Tidak Setuju

2 = Tidak Setuju

3 = Netral

4 = Setuju

5 = Sangat Setuju

Bagian 2 : pertanyaan mengenai variabel penelitian

No	Pertanyaan	Skala				
		1	2	3	4	5
	Aktivitas Pemasaran Media Sosial					
1	Saya merasa senang berinteraksi dengan Mixue melalui Instagram					
2	Saya merasa konten Instagram yang dibagikan oleh Mixue menarik					
3	Saya merasa Instagram Mixue memungkinkan untuk berbagi informasi dengan orang lain					
4	Saya merasa mudah untuk menyampaikan pendapat melalui Instagram Mixue					
5	Instagram Mixue selalu membagikan konten terbaru					
6	Saya merasa Instagram Mixue memiliki gaya modern					
7	Instagram Mixue memberikan informasi yang saya butuhkan					
8	Saya mudah memperoleh informasi yang dibutuhkan berkat petunjuk di Instagram Mixue					
9	Saya menyukai iklan yang diunggah pada Instagram Mixue					
10	Iklan pada Instagram Mixue secara positif mempengaruhi perhatian saya terhadap merek Mixue					
	Ekuitas Merek					
1	Dibandingkan merek lain,saya merasa Mixue memiliki kualitas yang tinggi					
2	Dibandingkan merek lain,saya merasa Mixue adalah yang terbaik					
3	Dibandingkan merek lain,saya merasa produk Mixue memiliki tingkat konsisten yang tinggi					
4	Karakteristik Mixue muncul di benak saya dengan cepat					
5	Saya dapat mengingat dengan cepat kualitas produk Mixue					
6	Saya merasa puas pada pembelian terakhir produk Mixue					

7	Saya akan membeli produk Mixue lagi pada kesempatan berikutnya					
8	Saya selalu menyadari keberadaan Mixue					
9	Saya selalu menyadari atau mengetahui karakteristik produk Mixue					
10	Saya selalu ingat logo Mixue					
<i>E-WOM</i>						
1	Saya lebih sering berbicara tentang produk Mixue dibandingkan merek lain yang juga menggunakan Instagram					
2	Saya berbicara tentang Mixue kepada banyak orang					
3	Saya bersedia merekomendasikan produk Mixue kepada orang lain					
4	Saya bangga mengatakan kepada orang lain bahwa saya adalah pelanggan Mixue					
5	Saya banyak mengatakan hal positif tentang Mixue kepada orang lain					
6	Saya banyak mengatakan hal negative tentang Mixue kepada orang lain					
7	Saya berbicara secara tidak menyenangkan mengenai Mixue kepada orang lain					
8	Saya pernah membahas harga produk Mixue					
9	Saya pernah membahas berbagai jenis produk Mixue					
10	Saya pernah membahas kualitas rasa produk Mixue					
Niat Beli						
1	Melihat Instagram Mixue membantu saya untuk membuat keputusan yang lebih baik sebelum membeli produk Mixue					
2	Melihat Instagram Mixue meningkatkan niat saya untuk membeli produk Mixue					
3	Saya pasti akan membeli produk yang ditampilkan pada Instagram Mixue					
4	Saya merasa memiliki keinginan tinggi untuk menjadi pelanggan Mixue					

LAMPIRAN II

PROFILING RESPONDEN DAN JAWABAN PERTANYAAN

No	Cap waktu	Jenis Kelamin	Usia	Durasi menggunakan Instagram dalam satu hari	Apakah anda pernah membeli produk Mixue?	Apakah anda pernah mengunjungi akun Instagram Mixue?
1	2023/03/28 12:13:07 PM GMT+7	Wanita	< 24 tahun	> 6 jam	Ya	Ya
2	2023/03/28 12:13:11 PM GMT+7	Wanita	< 24 tahun	< 3 jam	Ya	Ya
3	2023/03/28 12:15:29 PM GMT+7	Pria	< 24 tahun	> 3 jam - 6 jam	Ya	Ya
4	2023/03/28 12:16:10 PM GMT+7	Wanita	< 24 tahun	> 3 jam - 6 jam	Ya	Ya
5	2023/03/28 12:25:58 PM GMT+7	Pria	< 24 tahun	> 3 jam - 6 jam	Ya	Ya
6	2023/03/28 12:27:52 PM GMT+7	Wanita	< 24 tahun	< 3 jam	Ya	Ya
7	2023/03/28 12:29:48 PM GMT+7	Wanita	< 24 tahun	< 3 jam	Ya	Ya
8	2023/03/28 12:30:16 PM GMT+7	Wanita	< 24 tahun	> 6 jam	Ya	Ya
9	2023/03/28 12:30:34 PM GMT+7	Wanita	< 24 tahun	> 3 jam - 6 jam	Ya	Ya
10	2023/03/28 12:35:30 PM GMT+7	Wanita	< 24 tahun	< 3 jam	Ya	Ya
11	2023/03/28 12:37:10 PM GMT+7	Wanita	< 24 tahun	> 6 jam	Ya	Ya

12	2023/03/28 12:40:56 PM GMT+7	Pria	< 24 tahun	< 3 jam	Ya	Ya
13	2023/03/28 12:41:15 PM GMT+7	Pria	45 - 54 tahun	> 3 jam - 6 jam	Ya	Ya
14	2023/03/28 12:46:54 PM GMT+7	Wanita	< 24 tahun	< 3 jam	Ya	Ya
15	2023/03/28 12:47:31 PM GMT+7	Wanita	< 24 tahun	> 3 jam - 6 jam	Ya	Ya
16	2023/03/28 12:47:41 PM GMT+7	Pria	< 24 tahun	< 3 jam	Ya	Ya
17	2023/03/28 12:50:09 PM GMT+7	Wanita	< 24 tahun	< 3 jam	Ya	Ya
18	2023/03/28 12:51:32 PM GMT+7	Wanita	< 24 tahun	> 3 jam - 6 jam	Ya	Ya
19	2023/03/28 12:51:46 PM GMT+7	Pria	24 - 35 tahun	< 3 jam	Ya	Ya
20	2023/03/28 12:52:24 PM GMT+7	Wanita	< 24 tahun	> 3 jam - 6 jam	Ya	Ya
21	2023/03/28 12:57:12 PM GMT+7	Pria	45 - 54 tahun	< 3 jam	Ya	Ya
22	2023/03/28 12:58:57 PM GMT+7	Wanita	< 24 tahun	< 3 jam	Ya	Ya
23	2023/03/28 1:01:17 PM GMT+7	Pria	< 24 tahun	> 3 jam - 6 jam	Ya	Ya
24	2023/03/28 1:03:57 PM GMT+7	Wanita	< 24 tahun	< 3 jam	Ya	Ya
25	2023/03/28 1:05:58 PM GMT+7	Pria	< 24 tahun	< 3 jam	Ya	Ya
26	2023/03/28 1:06:35 PM GMT+7	Wanita	< 24 tahun	< 3 jam	Ya	Ya

27	2023/03/28 1:11:19 PM GMT+7	Wanita	< 24 tahun	> 3 jam - 6 jam	Ya	Ya
28	2023/03/28 1:11:45 PM GMT+7	Pria	< 24 tahun	< 3 jam	Ya	Ya
29	2023/03/28 1:14:34 PM GMT+7	Pria	< 24 tahun	> 3 jam - 6 jam	Ya	Ya
30	2023/03/28 1:15:53 PM GMT+7	Wanita	45 - 54 tahun	< 3 jam	Ya	Ya
31	2023/03/28 1:16:48 PM GMT+7	Pria	35 - 44 tahun	< 3 jam	Ya	Ya
32	2023/03/28 1:17:37 PM GMT+7	Wanita	< 24 tahun	< 3 jam	Ya	Ya
33	2023/03/28 1:18:11 PM GMT+7	Pria	24 - 35 tahun	> 3 jam - 6 jam	Ya	Ya
34	2023/03/28 1:19:27 PM GMT+7	Wanita	< 24 tahun	> 6 jam	Ya	Ya
35	2023/03/28 1:20:28 PM GMT+7	Pria	< 24 tahun	< 3 jam	Ya	Ya
36	2023/03/28 1:23:36 PM GMT+7	Wanita	< 24 tahun	> 3 jam - 6 jam	Ya	Ya
37	2023/03/28 1:23:54 PM GMT+7	Pria	45 - 54 tahun	> 3 jam - 6 jam	Ya	Ya
38	2023/03/28 1:25:29 PM GMT+7	Wanita	35 - 44 tahun	< 3 jam	Ya	Ya
39	2023/03/28 1:30:09 PM GMT+7	Wanita	< 24 tahun	< 3 jam	Ya	Ya
40	2023/03/28 1:30:46 PM GMT+7	Wanita	24 - 35 tahun	< 3 jam	Ya	Ya
41	2023/03/28 1:33:23 PM GMT+7	Wanita	< 24 tahun	> 3 jam - 6 jam	Ya	Ya

42	2023/03/28 1:35:39 PM GMT+7	Pria	< 24 tahun	> 6 jam	Ya	Ya
43	2023/03/28 1:39:05 PM GMT+7	Wanita	< 24 tahun	< 3 jam	Ya	Ya
44	2023/03/28 1:39:30 PM GMT+7	Pria	< 24 tahun	< 3 jam	Ya	Ya
45	2023/03/28 1:40:00 PM GMT+7	Wanita	< 24 tahun	> 3 jam - 6 jam	Ya	Ya
46	2023/03/28 1:40:51 PM GMT+7	Pria	35 - 44 tahun	> 3 jam - 6 jam	Ya	Ya
47	2023/03/28 1:42:13 PM GMT+7	Pria	< 24 tahun	< 3 jam	Ya	Ya
48	2023/03/28 1:43:41 PM GMT+7	Pria	45 - 54 tahun	< 3 jam	Ya	Ya
49	2023/03/28 1:44:21 PM GMT+7	Wanita	< 24 tahun	> 3 jam - 6 jam	Ya	Ya
50	2023/03/28 1:45:45 PM GMT+7	Pria	< 24 tahun	< 3 jam	Ya	Ya
51	2023/03/28 1:46:02 PM GMT+7	Pria	45 - 54 tahun	< 3 jam	Ya	Ya
52	2023/03/28 1:51:07 PM GMT+7	Pria	< 24 tahun	> 3 jam - 6 jam	Ya	Ya
53	2023/03/28 1:57:27 PM GMT+7	Wanita	< 24 tahun	> 3 jam - 6 jam	Ya	Ya
54	2023/03/28 2:00:20 PM GMT+7	Wanita	< 24 tahun	> 3 jam - 6 jam	Ya	Ya
55	2023/03/28 2:01:02 PM GMT+7	Wanita	< 24 tahun	> 3 jam - 6 jam	Ya	Ya
56	2023/03/28 2:01:05 PM GMT+7	Wanita	< 24 tahun	< 3 jam	Ya	Ya

57	2023/03/28 2:01:39 PM GMT+7	Pria	< 24 tahun	> 3 jam - 6 jam	Ya	Ya
58	2023/03/28 2:01:52 PM GMT+7	Pria	< 24 tahun	> 3 jam - 6 jam	Ya	Ya
59	2023/03/28 2:03:12 PM GMT+7	Wanita	< 24 tahun	> 3 jam - 6 jam	Ya	Ya
60	2023/03/28 2:03:37 PM GMT+7	Wanita	< 24 tahun	> 3 jam - 6 jam	Ya	Ya
61	2023/03/28 2:06:56 PM GMT+7	Pria	< 24 tahun	> 3 jam - 6 jam	Ya	Ya
62	2023/03/28 2:07:56 PM GMT+7	Wanita	24 - 35 tahun	> 3 jam - 6 jam	Ya	Ya
63	2023/03/28 2:09:50 PM GMT+7	Pria	< 24 tahun	> 6 jam	Ya	Ya
64	2023/03/28 2:12:54 PM GMT+7	Wanita	< 24 tahun	< 3 jam	Ya	Ya
65	2023/03/28 2:14:29 PM GMT+7	Wanita	< 24 tahun	> 6 jam	Ya	Ya
66	2023/03/28 2:15:43 PM GMT+7	Wanita	24 - 35 tahun	> 6 jam	Ya	Ya
67	2023/03/28 2:15:44 PM GMT+7	Pria	< 24 tahun	> 6 jam	Ya	Ya
68	2023/03/28 2:16:36 PM GMT+7	Wanita	< 24 tahun	< 3 jam	Ya	Ya
69	2023/03/28 2:22:11 PM GMT+7	Pria	45 - 54 tahun	> 6 jam	Ya	Ya
70	2023/03/28 2:25:47 PM GMT+7	Wanita	< 24 tahun	> 3 jam - 6 jam	Ya	Ya
71	2023/03/28 2:26:09 PM GMT+7	Pria	24 - 35 tahun	< 3 jam	Ya	Ya

72	2023/03/28 2:31:08 PM GMT+7	Pria	< 24 tahun	< 3 jam	Ya	Ya
73	2023/03/28 2:32:11 PM GMT+7	Wanita	24 - 35 tahun	> 3 jam - 6 jam	Ya	Ya
74	2023/03/28 2:32:59 PM GMT+7	Pria	< 24 tahun	< 3 jam	Ya	Ya
75	2023/03/28 2:38:26 PM GMT+7	Wanita	< 24 tahun	> 3 jam - 6 jam	Ya	Ya
76	2023/03/28 2:39:59 PM GMT+7	Pria	< 24 tahun	< 3 jam	Ya	Ya
77	2023/03/28 2:41:36 PM GMT+7	Pria	< 24 tahun	< 3 jam	Ya	Ya
78	2023/03/28 2:44:45 PM GMT+7	Pria	< 24 tahun	< 3 jam	Ya	Ya
79	2023/03/28 2:45:02 PM GMT+7	Wanita	< 24 tahun	> 3 jam - 6 jam	Ya	Ya
80	2023/03/28 2:45:18 PM GMT+7	Wanita	< 24 tahun	> 6 jam	Ya	Ya
81	2023/03/28 2:45:25 PM GMT+7	Wanita	< 24 tahun	> 6 jam	Ya	Ya
82	2023/03/28 2:45:30 PM GMT+7	Pria	< 24 tahun	< 3 jam	Ya	Ya
83	2023/03/28 2:47:40 PM GMT+7	Pria	< 24 tahun	< 3 jam	Ya	Ya
84	2023/03/28 2:48:53 PM GMT+7	Pria	< 24 tahun	> 3 jam - 6 jam	Ya	Ya
85	2023/03/28 2:51:34 PM GMT+7	Wanita	< 24 tahun	< 3 jam	Ya	Ya
86	2023/03/28 2:52:48 PM GMT+7	Pria	< 24 tahun	< 3 jam	Ya	Ya

87	2023/03/28 2:53:40 PM GMT+7	Pria	< 24 tahun	< 3 jam	Ya	Ya
88	2023/03/28 2:54:27 PM GMT+7	Wanita	< 24 tahun	> 3 jam - 6 jam	Ya	Ya
89	2023/03/28 2:54:42 PM GMT+7	Wanita	< 24 tahun	> 6 jam	Ya	Ya
90	2023/03/28 2:58:03 PM GMT+7	Wanita	< 24 tahun	> 3 jam - 6 jam	Ya	Ya
91	2023/03/28 2:58:09 PM GMT+7	Pria	< 24 tahun	> 3 jam - 6 jam	Ya	Ya
92	2023/03/28 2:58:51 PM GMT+7	Wanita	< 24 tahun	> 3 jam - 6 jam	Ya	Ya
93	2023/03/28 3:01:47 PM GMT+7	Wanita	< 24 tahun	> 6 jam	Ya	Ya
94	2023/03/28 3:03:26 PM GMT+7	Pria	< 24 tahun	< 3 jam	Ya	Ya
95	2023/03/28 3:04:10 PM GMT+7	Pria	< 24 tahun	< 3 jam	Ya	Ya
96	2023/03/28 3:04:58 PM GMT+7	Pria	< 24 tahun	> 3 jam - 6 jam	Ya	Ya
97	2023/03/28 3:10:15 PM GMT+7	Wanita	< 24 tahun	< 3 jam	Ya	Ya
98	2023/03/28 3:10:36 PM GMT+7	Wanita	< 24 tahun	> 3 jam - 6 jam	Ya	Ya
99	2023/03/28 3:15:21 PM GMT+7	Pria	< 24 tahun	< 3 jam	Ya	Ya
100	2023/03/28 3:16:47 PM GMT+7	Pria	< 24 tahun	< 3 jam	Ya	Ya
101	2023/03/28 3:17:53 PM GMT+7	Wanita	< 24 tahun	> 3 jam - 6 jam	Ya	Ya

102	2023/03/28 3:19:31 PM GMT+7	Pria	< 24 tahun	< 3 jam	Ya	Ya
103	2023/03/28 3:22:43 PM GMT+7	Wanita	< 24 tahun	< 3 jam	Ya	Ya
104	2023/03/28 3:24:58 PM GMT+7	Wanita	< 24 tahun	< 3 jam	Ya	Ya
105	2023/03/28 3:26:37 PM GMT+7	Wanita	< 24 tahun	> 3 jam - 6 jam	Ya	Ya
106	2023/03/28 3:27:11 PM GMT+7	Pria	< 24 tahun	< 3 jam	Ya	Ya
107	2023/03/28 3:27:50 PM GMT+7	Pria	< 24 tahun	> 3 jam - 6 jam	Ya	Ya
108	2023/03/28 3:28:03 PM GMT+7	Pria	< 24 tahun	< 3 jam	Ya	Ya
109	2023/03/28 3:28:35 PM GMT+7	Wanita	< 24 tahun	> 3 jam - 6 jam	Ya	Ya
110	2023/03/28 3:33:41 PM GMT+7	Pria	35 - 44 tahun	< 3 jam	Ya	Ya
111	2023/03/28 3:34:17 PM GMT+7	Wanita	< 24 tahun	> 3 jam - 6 jam	Ya	Ya
112	2023/03/28 3:39:00 PM GMT+7	Pria	< 24 tahun	< 3 jam	Ya	Ya
113	2023/03/28 3:44:24 PM GMT+7	Pria	< 24 tahun	< 3 jam	Ya	Ya
114	2023/03/28 3:46:22 PM GMT+7	Wanita	24 - 35 tahun	> 3 jam - 6 jam	Ya	Ya
115	2023/03/28 3:48:42 PM GMT+7	Wanita	< 24 tahun	> 3 jam - 6 jam	Ya	Ya
116	2023/03/28 3:49:22 PM GMT+7	Pria	< 24 tahun	< 3 jam	Ya	Ya

117	2023/03/28 3:52:41 PM GMT+7	Wanita	< 24 tahun	> 3 jam - 6 jam	Ya	Ya
118	2023/03/28 3:54:44 PM GMT+7	Wanita	< 24 tahun	> 3 jam - 6 jam	Ya	Ya
119	2023/03/28 4:10:56 PM GMT+7	Wanita	< 24 tahun	> 6 jam	Ya	Ya
120	2023/03/28 4:17:02 PM GMT+7	Pria	< 24 tahun	< 3 jam	Ya	Ya
121	2023/03/28 4:20:00 PM GMT+7	Pria	< 24 tahun	< 3 jam	Ya	Ya
122	2023/03/28 4:22:12 PM GMT+7	Wanita	< 24 tahun	< 3 jam	Ya	Ya
123	2023/03/28 4:29:05 PM GMT+7	Pria	< 24 tahun	< 3 jam	Ya	Ya
124	2023/03/28 4:29:49 PM GMT+7	Wanita	< 24 tahun	< 3 jam	Ya	Ya
125	2023/03/28 4:32:07 PM GMT+7	Pria	24 - 35 tahun	> 3 jam - 6 jam	Ya	Ya
126	2023/03/28 4:32:07 PM GMT+7	Wanita	24 - 35 tahun	> 3 jam - 6 jam	Ya	Ya
127	2023/03/28 4:32:10 PM GMT+7	Wanita	24 - 35 tahun	< 3 jam	Ya	Ya
128	2023/03/28 4:33:54 PM GMT+7	Pria	< 24 tahun	> 3 jam - 6 jam	Ya	Ya
129	2023/03/28 4:34:37 PM GMT+7	Pria	35 - 44 tahun	> 3 jam - 6 jam	Ya	Ya
130	2023/03/28 4:56:43 PM GMT+7	Pria	< 24 tahun	> 3 jam - 6 jam	Ya	Ya
131	2023/03/28 5:18:19 PM GMT+7	Wanita	< 24 tahun	< 3 jam	Ya	Ya

132	2023/03/28 5:25:10 PM GMT+7	Pria	< 24 tahun	> 3 jam - 6 jam	Ya	Ya
133	2023/03/28 5:28:28 PM GMT+7	Pria	< 24 tahun	> 3 jam - 6 jam	Ya	Ya
134	2023/03/28 5:32:26 PM GMT+7	Pria	< 24 tahun	> 3 jam - 6 jam	Ya	Ya
135	2023/03/28 5:40:05 PM GMT+7	Wanita	< 24 tahun	< 3 jam	Ya	Ya
136	2023/03/28 5:43:03 PM GMT+7	Wanita	< 24 tahun	< 3 jam	Ya	Ya
137	2023/03/28 5:43:12 PM GMT+7	Wanita	< 24 tahun	< 3 jam	Ya	Ya
138	2023/03/28 5:43:46 PM GMT+7	Wanita	< 24 tahun	> 3 jam - 6 jam	Ya	Ya
139	2023/03/28 5:47:36 PM GMT+7	Wanita	< 24 tahun	< 3 jam	Ya	Ya
140	2023/03/28 6:02:57 PM GMT+7	Wanita	< 24 tahun	> 3 jam - 6 jam	Ya	Ya
141	2023/03/28 6:13:08 PM GMT+7	Wanita	< 24 tahun	> 3 jam - 6 jam	Ya	Ya
142	2023/03/28 6:17:09 PM GMT+7	Wanita	< 24 tahun	< 3 jam	Ya	Ya
143	2023/03/28 6:19:31 PM GMT+7	Wanita	< 24 tahun	> 3 jam - 6 jam	Ya	Ya
144	2023/03/28 6:21:06 PM GMT+7	Pria	24 - 35 tahun	> 6 jam	Ya	Ya
145	2023/03/28 6:43:15 PM GMT+7	Wanita	< 24 tahun	> 3 jam - 6 jam	Ya	Ya
146	2023/03/28 6:51:21 PM 146GMT+7	Wanita	< 24 tahun	> 3 jam - 6 jam	Ya	Ya

147	2023/03/28 6:58:58 PM GMT+7	Wanita	< 24 tahun	> 3 jam - 6 jam	Ya	Ya
148	2023/03/28 7:00:57 PM GMT+7	Pria	< 24 tahun	> 6 jam	Ya	Ya
149	2023/03/28 7:02:04 PM GMT+7	Pria	24 - 35 tahun	< 3 jam	Ya	Ya
150	2023/03/28 7:05:16 PM GMT+7	Pria	35 - 44 tahun	< 3 jam	Ya	Ya
151	2023/03/28 7:08:33 PM GMT+7	Pria	< 24 tahun	< 3 jam	Ya	Ya
152	2023/03/28 7:09:25 PM GMT+7	Wanita	< 24 tahun	< 3 jam	Ya	Ya
153	2023/03/28 7:13:36 PM GMT+7	Wanita	< 24 tahun	> 3 jam - 6 jam	Ya	Ya
154	2023/03/28 7:15:46 PM GMT+7	Pria	< 24 tahun	< 3 jam	Ya	Ya
155	2023/03/28 7:16:34 PM GMT+7	Pria	24 - 35 tahun	< 3 jam	Ya	Ya
156	2023/03/28 7:18:05 PM GMT+7	Pria	< 24 tahun	> 3 jam - 6 jam	Ya	Ya
157	2023/03/28 7:25:08 PM GMT+7	Wanita	< 24 tahun	> 3 jam - 6 jam	Ya	Ya
158	2023/03/28 7:31:13 PM GMT+7	Wanita	< 24 tahun	> 3 jam - 6 jam	Ya	Ya
159	2023/03/28 7:31:53 PM GMT+7	Pria	< 24 tahun	> 3 jam - 6 jam	Ya	Ya
160	2023/03/28 7:34:01 PM GMT+7	Wanita	< 24 tahun	> 3 jam - 6 jam	Ya	Ya
161	2023/03/28 7:35:43 PM GMT+7	Wanita	< 24 tahun	< 3 jam	Ya	Ya

162	2023/03/28 7:37:49 PM GMT+7	Pria	< 24 tahun	< 3 jam	Ya	Ya
163	2023/03/28 7:40:39 PM GMT+7	Pria	< 24 tahun	< 3 jam	Ya	Ya
164	2023/03/28 7:41:03 PM GMT+7	Pria	< 24 tahun	> 3 jam - 6 jam	Ya	Ya
165	2023/03/28 7:41:24 PM GMT+7	Wanita	< 24 tahun	< 3 jam	Ya	Ya
166	2023/03/28 7:45:03 PM GMT+7	Wanita	< 24 tahun	< 3 jam	Ya	Ya
167	2023/03/28 7:46:49 PM GMT+7	Pria	24 - 35 tahun	> 3 jam - 6 jam	Ya	Ya
168	2023/03/28 7:54:54 PM GMT+7	Pria	< 24 tahun	> 3 jam - 6 jam	Ya	Ya
169	2023/03/28 7:55:50 PM GMT+7	Wanita	24 - 35 tahun	< 3 jam	Ya	Ya
170	2023/03/28 7:56:45 PM GMT+7	Wanita	24 - 35 tahun	< 3 jam	Ya	Ya
171	2023/03/28 7:57:28 PM GMT+7	Pria	< 24 tahun	> 3 jam - 6 jam	Ya	Ya
172	2023/03/28 7:58:05 PM GMT+7	Pria	< 24 tahun	< 3 jam	Ya	Ya
173	2023/03/28 8:01:41 PM GMT+7	Pria	< 24 tahun	< 3 jam	Ya	Ya
174	2023/03/28 8:02:29 PM GMT+7	Wanita	24 - 35 tahun	> 3 jam - 6 jam	Ya	Ya
175	2023/03/28 8:09:38 PM GMT+7	Pria	24 - 35 tahun	> 3 jam - 6 jam	Ya	Ya
176	2023/03/28 8:11:35 PM GMT+7	Pria	< 24 tahun	< 3 jam	Ya	Ya

177	2023/03/28 8:11:36 PM GMT+7	Wanita	< 24 tahun	> 3 jam - 6 jam	Ya	Ya
178	2023/03/28 8:12:27 PM GMT+7	Pria	24 - 35 tahun	> 6 jam	Ya	Ya
179	2023/03/28 8:12:52 PM GMT+7	Wanita	< 24 tahun	< 3 jam	Ya	Ya
180	2023/03/28 8:13:15 PM GMT+7	Wanita	24 - 35 tahun	< 3 jam	Ya	Ya
181	2023/03/28 8:15:32 PM GMT+7	Pria	45 - 54 tahun	> 3 jam - 6 jam	Ya	Ya
182	2023/03/28 8:24:01 PM GMT+7	Wanita	< 24 tahun	> 3 jam - 6 jam	Ya	Ya
183	2023/03/28 8:24:02 PM GMT+7	Wanita	< 24 tahun	> 3 jam - 6 jam	Ya	Ya
184	2023/03/28 8:24:43 PM GMT+7	Pria	< 24 tahun	> 3 jam - 6 jam	Ya	Ya
185	2023/03/28 8:26:13 PM GMT+7	Wanita	< 24 tahun	> 6 jam	Ya	Ya
186	2023/03/28 8:26:43 PM GMT+7	Wanita	< 24 tahun	> 3 jam - 6 jam	Ya	Ya
187	2023/03/28 8:30:29 PM GMT+7	Wanita	24 - 35 tahun	< 3 jam	Ya	Ya
188	2023/03/28 8:34:08 PM GMT+7	Wanita	24 - 35 tahun	> 3 jam - 6 jam	Ya	Ya
189	2023/03/28 8:37:56 PM GMT+7	Wanita	< 24 tahun	< 3 jam	Ya	Ya
190	2023/03/28 8:44:06 PM GMT+7	Wanita	24 - 35 tahun	> 3 jam - 6 jam	Ya	Ya
191	2023/03/28 8:52:23 PM GMT+7	Wanita	24 - 35 tahun	< 3 jam	Ya	Ya

192	2023/03/28 8:54:24 PM GMT+7	Pria	< 24 tahun	> 3 jam - 6 jam	Ya	Ya
193	2023/03/28 8:55:18 PM GMT+7	Wanita	< 24 tahun	> 3 jam - 6 jam	Ya	Ya
194	2023/03/28 8:58:57 PM GMT+7	Wanita	< 24 tahun	> 6 jam	Ya	Ya
195	2023/03/28 8:59:51 PM GMT+7	Pria	< 24 tahun	> 6 jam	Ya	Ya
196	2023/03/28 9:18:09 PM GMT+7	Wanita	< 24 tahun	> 3 jam - 6 jam	Ya	Ya
197	2023/03/28 9:19:12 PM GMT+7	Pria	< 24 tahun	< 3 jam	Ya	Ya
198	2023/03/28 9:25:55 PM GMT+7	Pria	< 24 tahun	< 3 jam	Ya	Ya
199	2023/03/28 9:27:04 PM GMT+7	Wanita	24 - 35 tahun	> 3 jam - 6 jam	Ya	Ya
200	2023/03/28 9:40:31 PM GMT+7	Wanita	< 24 tahun	> 3 jam - 6 jam	Ya	Ya
201	2023/03/28 9:43:28 PM GMT+7	Wanita	< 24 tahun	> 3 jam - 6 jam	Ya	Ya
202	2023/03/28 9:47:31 PM GMT+7	Pria	< 24 tahun	> 3 jam - 6 jam	Ya	Ya
203	2023/03/28 9:49:22 PM GMT+7	Pria	< 24 tahun	< 3 jam	Ya	Ya
204	2023/03/28 9:53:37 PM GMT+7	Wanita	24 - 35 tahun	< 3 jam	Ya	Ya
205	2023/03/28 9:56:54 PM GMT+7	Wanita	< 24 tahun	> 3 jam - 6 jam	Ya	Ya
206	2023/03/28 10:03:28 PM GMT+7	Wanita	< 24 tahun	> 6 jam	Ya	Ya

207	2023/03/28 10:13:46 PM GMT+7	Pria	24 - 35 tahun	> 6 jam	Ya	Ya
208	2023/03/28 10:24:29 PM GMT+7	Wanita	24 - 35 tahun	< 3 jam	Ya	Ya
209	2023/03/28 10:25:53 PM GMT+7	Wanita	< 24 tahun	> 3 jam - 6 jam	Ya	Ya
210	2023/03/28 10:32:34 PM GMT+7	Pria	< 24 tahun	> 6 jam	Ya	Ya
211	2023/03/28 10:32:49 PM GMT+7	Wanita	< 24 tahun	> 3 jam - 6 jam	Ya	Ya
212	2023/03/28 10:34:18 PM GMT+7	Wanita	< 24 tahun	> 6 jam	Ya	Ya
213	2023/03/28 10:35:37 PM GMT+7	Wanita	< 24 tahun	> 3 jam - 6 jam	Ya	Ya
214	2023/03/28 10:35:59 PM GMT+7	Pria	< 24 tahun	> 3 jam - 6 jam	Ya	Ya
215	2023/03/28 10:36:03 PM GMT+7	Wanita	< 24 tahun	< 3 jam	Ya	Ya
216	2023/03/28 10:38:50 PM GMT+7	Pria	< 24 tahun	> 3 jam - 6 jam	Ya	Ya
217	2023/03/28 10:40:28 PM GMT+7	Pria	< 24 tahun	< 3 jam	Ya	Ya
218	2023/03/28 10:43:26 PM GMT+7	Wanita	< 24 tahun	< 3 jam	Ya	Ya
219	2023/03/28 10:44:36 PM GMT+7	Pria	< 24 tahun	> 3 jam - 6 jam	Ya	Ya
220	2023/03/28 10:46:25 PM GMT+7	Wanita	< 24 tahun	< 3 jam	Ya	Ya
221	2023/03/28 10:46:38 PM GMT+7	Wanita	< 24 tahun	> 3 jam - 6 jam	Ya	Ya

222	2023/03/28 10:49:03 PM GMT+7	Wanita	24 - 35 tahun	> 3 jam - 6 jam	Ya	Ya
223	2023/03/28 10:57:17 PM GMT+7	Pria	24 - 35 tahun	< 3 jam	Ya	Ya
224	2023/03/28 11:04:20 PM GMT+7	Wanita	< 24 tahun	> 3 jam - 6 jam	Ya	Ya
225	2023/03/28 11:12:41 PM GMT+7	Pria	< 24 tahun	> 3 jam - 6 jam	Ya	Ya
226	2023/03/28 11:13:50 PM GMT+7	Wanita	< 24 tahun	> 3 jam - 6 jam	Ya	Ya
227	2023/03/28 11:14:14 PM GMT+7	Pria	< 24 tahun	< 3 jam	Ya	Ya
228	2023/03/28 11:14:29 PM GMT+7	Wanita	24 - 35 tahun	> 3 jam - 6 jam	Ya	Ya
229	2023/03/28 11:26:07 PM GMT+7	Wanita	< 24 tahun	< 3 jam	Ya	Ya
230	2023/03/28 11:27:48 PM GMT+7	Pria	< 24 tahun	< 3 jam	Ya	Ya
231	2023/03/28 11:43:50 PM GMT+7	Wanita	< 24 tahun	> 3 jam - 6 jam	Ya	Ya
232	2023/03/29 12:05:59 AM GMT+7	Pria	< 24 tahun	< 3 jam	Ya	Ya
233	2023/03/29 12:07:23 AM GMT+7	Wanita	< 24 tahun	> 3 jam - 6 jam	Ya	Ya
234	2023/03/29 12:11:42 AM GMT+7	Wanita	< 24 tahun	> 3 jam - 6 jam	Ya	Ya
235	2023/03/29 12:27:34 AM GMT+7	Wanita	< 24 tahun	< 3 jam	Ya	Ya
236	2023/03/29 12:37:52 AM GMT+7	Pria	24 - 35 tahun	< 3 jam	Ya	Ya

237	2023/03/29 1:25:18 AM GMT+7	Wanita	24 - 35 tahun	< 3 jam	Ya	Ya
238	2023/03/29 3:53:59 AM GMT+7	Wanita	< 24 tahun	< 3 jam	Ya	Ya
239	2023/03/29 6:18:08 AM GMT+7	Wanita	< 24 tahun	> 3 jam - 6 jam	Ya	Ya
240	2023/03/29 6:57:41 AM GMT+7	Wanita	< 24 tahun	> 6 jam	Ya	Ya
241	2023/03/29 7:42:53 AM GMT+7	Wanita	< 24 tahun	< 3 jam	Ya	Ya
242	2023/03/29 7:47:48 AM GMT+7	Wanita	24 - 35 tahun	> 3 jam - 6 jam	Ya	Ya
243	2023/03/29 7:58:56 AM GMT+7	Wanita	< 24 tahun	< 3 jam	Ya	Ya
244	2023/03/29 8:27:00 AM GMT+7	Wanita	< 24 tahun	< 3 jam	Ya	Ya
245	2023/03/29 9:56:19 AM GMT+7	Wanita	< 24 tahun	< 3 jam	Ya	Ya
246	2023/03/29 10:14:11 AM GMT+7	Wanita	< 24 tahun	> 3 jam - 6 jam	Ya	Ya
247	2023/03/29 10:40:46 AM GMT+7	Pria	< 24 tahun	< 3 jam	Ya	Ya
248	2023/03/29 11:10:37 AM GMT+7	Wanita	< 24 tahun	> 3 jam - 6 jam	Ya	Ya
249	2023/03/29 1:15:01 PM GMT+7	Wanita	< 24 tahun	> 3 jam - 6 jam	Ya	Ya
250	2023/03/29 2:01:07 PM GMT+7	Wanita	< 24 tahun	< 3 jam	Ya	Ya
251	2023/03/29 2:03:35 PM GMT+7	Pria	< 24 tahun	> 3 jam - 6 jam	Ya	Ya

252	2023/03/29 3:44:10 PM GMT+7	Wanita	< 24 tahun	> 3 jam - 6 jam	Ya	Ya
253	2023/03/29 3:49:59 PM GMT+7	Wanita	< 24 tahun	> 3 jam - 6 jam	Ya	Ya
254	2023/03/29 3:54:34 PM GMT+7	Wanita	< 24 tahun	< 3 jam	Ya	Ya
255	2023/03/29 4:43:41 PM GMT+7	Wanita	< 24 tahun	< 3 jam	Ya	Ya
256	2023/03/29 5:26:39 PM GMT+7	Pria	< 24 tahun	< 3 jam	Ya	Ya
257	2023/03/29 5:53:14 PM GMT+7	Wanita	< 24 tahun	> 3 jam - 6 jam	Ya	Ya
258	2023/03/29 8:05:34 PM GMT+7	Wanita	< 24 tahun	> 3 jam - 6 jam	Ya	Ya
259	2023/03/29 8:10:28 PM GMT+7	Wanita	< 24 tahun	< 3 jam	Ya	Ya
260	2023/03/29 9:31:30 PM GMT+7	Wanita	< 24 tahun	< 3 jam	Ya	Ya
261	2023/03/29 11:48:55 PM GMT+7	Wanita	< 24 tahun	< 3 jam	Ya	Ya
262	2023/03/30 12:59:44 AM GMT+7	Wanita	< 24 tahun	> 3 jam - 6 jam	Ya	Ya
263	2023/03/30 6:59:38 AM GMT+7	Wanita	24 - 35 tahun	> 6 jam	Ya	Ya
264	2023/03/30 9:41:32 AM GMT+7	Wanita	< 24 tahun	> 3 jam - 6 jam	Ya	Ya
265	2023/03/30 9:46:35 AM GMT+7	Wanita	< 24 tahun	> 6 jam	Ya	Ya
266	2023/03/30 11:08:53 AM GMT+7	Wanita	< 24 tahun	< 3 jam	Ya	Ya

267	2023/03/30 11:11:32 AM GMT+7	Wanita	< 24 tahun	< 3 jam	Ya	Ya
268	2023/03/30 11:33:52 AM GMT+7	Wanita	< 24 tahun	< 3 jam	Ya	Ya
269	2023/03/30 12:37:25 PM GMT+7	Pria	< 24 tahun	< 3 jam	Ya	Ya
270	2023/03/30 2:30:07 PM GMT+7	Wanita	< 24 tahun	> 3 jam - 6 jam	Ya	Ya
271	2023/03/30 2:56:31 PM GMT+7	Wanita	< 24 tahun	> 3 jam - 6 jam	Ya	Ya
272	2023/03/30 7:45:39 PM GMT+7	Wanita	< 24 tahun	< 3 jam	Ya	Ya
273	2023/03/30 8:13:31 PM GMT+7	Wanita	< 24 tahun	> 6 jam	Ya	Ya
274	2023/03/30 8:23:18 PM GMT+7	Wanita	< 24 tahun	< 3 jam	Ya	Ya
275	2023/03/31 9:40:06 AM GMT+7	Pria	< 24 tahun	> 3 jam - 6 jam	Ya	Ya
276	2023/03/31 2:31:01 PM GMT+7	Wanita	< 24 tahun	> 3 jam - 6 jam	Ya	Ya
277	2023/03/31 6:47:30 PM GMT+7	Pria	< 24 tahun	< 3 jam	Ya	Ya
278	2023/04/01 11:38:23 AM GMT+7	Wanita	< 24 tahun	> 3 jam - 6 jam	Ya	Ya
279	2023/04/01 1:58:18 PM GMT+7	Wanita	< 24 tahun	< 3 jam	Ya	Ya
280	2023/04/01 3:29:30 PM GMT+7	Wanita	< 24 tahun	< 3 jam	Ya	Ya
281	2023/04/04 12:00:38 PM GMT+7	Wanita	< 24 tahun	> 3 jam - 6 jam	Ya	Ya

3	4	4	3	4	4	3	3	4	3	3	4	3	4	4	4	5	4	4	3	4	4	5	4	4	4	4	4	3	2	4	4	4	4		
3	4	4	4	3	4	4	4	4	3	4	3	3	3	4	5	5	4	4	4	3	3	4	3	3	4	4	4	5	5	3	3	3	3		
4	4	4	4	4	4	4	5	4	4	4	5	4	4	4	5	4	4	4	4	4	4	4	5	4	4	4	4	3	3	4	4	5	4		
2	3	4	3	3	4	3	4	4	4	3	3	3	5	3	5	4	5	5	5	3	3	4	3	3	4	4	5	4	4	4	3	3	2		
5	4	5	5	4	4	3	5	5	5	4	4	4	4	4	4	3	4	4	4	3	4	4	4	5	5	4	5	2	1	4	4	5	5		
3	3	3	3	3	3	3	3	3	3	3	3	3	3	3	3	3	3	3	3	3	3	3	3	3	3	3	3	2	3	3	3	3	3		
4	3	5	3	4	5	3	3	5	4	3	3	3	4	4	4	5	5	5	4	2	3	4	2	4	4	4	4	4	4	4	4	4	4		
3	3	3	3	3	3	3	3	5	3	2	2	2	5	5	3	4	5	5	5	1	2	2	3	3	4	4	4	5	3	3	3	3	3		
5	4	5	5	4	4	4	4	4	4	4	4	4	4	4	4	4	4	4	4	4	4	4	4	4	4	4	4	4	5	5	4	4	4	4	
4	4	4	4	4	4	4	4	4	4	4	4	4	4	4	4	4	4	4	4	4	4	4	4	4	4	4	4	4	4	4	4	4	4	4	
5	5	5	4	5	4	5	5	5	5	4	3	4	4	5	4	5	4	4	5	4	3	3	3	3	4	4	4	3	2	3	4	4	4	4	
4	4	5	4	5	4	4	4	4	4	4	4	4	4	4	4	4	4	4	4	5	4	4	4	4	4	4	4	4	4	4	4	4	4	3	
5	5	4	4	5	4	5	5	4	4	5	4	5	5	5	4	4	5	5	5	5	4	4	4	4	5	5	5	4	4	4	4	5	5	5	
3	3	4	4	4	4	4	4	4	4	4	5	4	4	4	4	4	4	4	4	4	4	4	4	4	2	3	3	3	3	5	4	4	4	2	
4	4	4	5	4	5	5	4	5	5	5	5	4	5	5	5	5	5	5	5	4	4	5	5	4	5	5	5	5	5	5	4	4	5	5	
3	3	3	3	3	3	3	3	3	3	3	3	3	3	3	3	3	3	3	3	3	3	3	3	3	3	3	3	3	3	3	3	3	3	3	
4	5	5	4	4	5	4	5	4	5	5	4	4	4	5	4	5	5	4	5	5	4	5	5	4	5	5	5	4	4	5	5	5	5	4	4
3	4	3	3	3	4	3	3	3	3	3	3	4	4	3	3	4	4	5	3	3	3	3	3	3	3	3	3	3	3	3	4	3	3	3	3
5	5	5	5	5	5	4	4	5	5	5	4	4	4	5	4	5	5	5	4	5	4	4	4	4	4	4	4	4	5	5	5	5	5	4	4
3	4	4	3	4	4	4	4	3	3	3	3	3	4	3	3	4	3	3	4	3	3	3	3	3	3	4	3	4	3	3	4	4	3	3	
4	4	4	4	4	4	4	4	4	4	4	4	4	4	4	4	4	4	4	4	4	4	4	4	4	4	4	4	4	4	2	2	4	4	4	4
4	4	5	5	5	5	5	5	5	5	5	5	5	5	5	5	5	5	5	5	5	5	5	5	5	5	5	5	5	5	5	5	5	5	4	4
4	4	4	4	5	5	4	4	4	5	4	3	4	4	4	5	4	4	4	4	4	4	4	4	4	4	4	4	4	5	5	4	5	4	4	4
3	3	3	3	4	4	4	5	3	5	3	5	3	4	5	5	5	5	5	5	2	1	4	3	3	3	3	3	4	3	4	3	4	3	4	3
3	3	4	4	4	3	4	3	2	3	4	4	4	3	4	4	5	5	4	5	2	3	2	3	3	4	4	4	4	4	4	3	3	3	3	3
2	4	5	5	4	4	2	4	2	2	1	1	1	2	4	4	2	5	4	5	1	1	2	1	4	5	5	5	4	4	5	2	1	1	1	1
3	3	4	3	4	4	3	4	3	5	4	4	4	5	5	5	5	5	5	5	3	3	4	4	4	4	4	4	2	2	4	4	4	4	4	4
4	4	4	4	4	4	4	4	4	4	4	4	4	4	4	4	4	4	4	4	4	4	4	4	4	4	4	4	4	4	4	4	4	5	4	5
4	5	4	4	5	5	5	5	4	5	4	2	4	5	5	5	4	5	4	5	4	4	4	4	4	5	5	5	4	2	4	4	4	4	4	4
3	3	3	3	4	4	3	3	3	4	4	3	4	5	5	5	4	5	5	5	2	3	3	3	3	5	3	4	4	4	3	4	2	2	2	2
4	4	4	5	4	5	4	5	4	5	4	4	4	5	4	4	5	5	4	5	4	4	5	4	4	4	4	4	5	5	4	5	4	5	4	5
4	4	3	3	4	4	4	4	3	4	4	3	4	4	4	4	4	4	4	4	3	3	4	3	3	4	4	3	4	4	4	4	4	4	4	2
5	5	5	5	5	5	4	5	4	4	4	4	5	5	5	5	5	5	5	5	4	4	4	5	4	5	5	5	3	3	4	4	5	5	5	5
3	4	4	3	3	4	5	4	3	4	4	3	4	5	4	3	4	5	2	5	3	3	3	3	3	5	4	4	4	4	3	4	4	3	3	
3	4	3	3	4	4	2	4	5	4	4	3	4	5	4	3	4	4	4	3	4	3	4	3	4	5	5	4	4	3	1	4	4	3	3	3
3	3	3	3	4	4	3	4	2	3	3	2	3	5	5	4	3	5	5	5	4	2	3	3	2	4	4	4	4	3	4	4	2	3	3	3
4	4	5	5	5	5	4	4	5	5	4	4	5	5	5	5	5	5	5	5	5	5	5	5	5	5	5	5	5	5	5	5	5	5	5	5
4	4	5	4	5	5	5	4	4	5	5	4	5	5	4	5	5	5	5	5	5	5	5	5	5	5	4	4	5	5	5	5	5	4	4	5
3	3	5	5	5	5	5	5	5	4	4	4	4	4	4	3	4	3	4	4	5	5	5	4	4	5	5	5	1	1	5	5	5	5	5	5
4	4	4	4	4	4	4	4	4	4	4	4	4	4	3	4	4	4	4	4	4	4	4	4	4	4	4	4	4	2	2	4	4	5	4	4
5	4	4	4	4	4	4	4	4	3	4	4	4	4	4	4	4	3	4	4	4	4	4	4	3	4	4	3	3	3	5	5	4	4	4	4

2	4	4	4	4	4	4	4	2	4	2	2	4	4	4	4	4	4	4	2	2	4	2	4	4	4	4	4	4	5	2	2	2	4		
4	4	5	3	5	5	4	5	5	5	4	4	5	5	5	5	5	5	4	5	3	3	4	4	4	5	4	4	3	4	4	4	3	4		
4	4	4	4	4	4	4	4	4	4	4	4	4	4	5	5	4	5	5	5	4	4	4	4	5	4	3	3	2	2	4	4	4	4		
4	4	4	4	4	4	4	4	4	4	3	3	3	3	3	4	4	4	4	3	3	3	4	3	3	4	4	4	4	4	4	4	4	4		
4	4	5	5	5	5	4	4	4	5	4	5	4	4	4	5	4	4	5	5	5	5	5	5	4	4	4	4	5	1	1	5	4	4	5	
3	4	4	3	4	4	4	4	3	3	4	3	4	4	4	3	4	5	5	5	3	3	4	3	4	4	4	4	4	4	4	4	3	3		
4	4	4	4	4	4	4	4	4	4	4	4	4	4	4	5	4	5	5	4	5	4	4	4	4	4	5	4	4	4	4	4	4	4		
2	4	5	2	5	4	4	4	4	4	2	4	4	4	4	4	4	4	4	2	4	4	4	4	4	5	4	4	5	5	4	4	4	4		
3	4	3	2	3	4	3	3	3	3	4	3	4	4	3	4	3	4	3	4	3	4	3	4	3	4	2	4	4	5	2	4	4	4	5	3
4	4	4	4	4	5	4	4	4	4	4	4	4	4	4	5	4	4	4	4	4	3	4	4	4	4	4	4	2	2	4	4	4	4	4	
2	2	3	3	3	3	3	3	3	3	3	3	4	3	4	4	4	4	4	4	4	4	4	4	4	4	4	4	4	2	2	5	5	5	5	
4	4	4	4	4	4	4	3	4	5	4	4	3	3	4	3	5	4	4	3	4	4	3	3	4	3	3	3	3	3	3	3	3	4	4	
4	4	4	3	4	3	4	4	3	4	3	4	5	5	4	4	4	4	4	5	2	4	3	3	4	4	4	4	4	4	4	3	3	3	3	
4	4	4	4	4	4	4	5	4	5	4	4	4	5	5	5	5	5	5	5	2	4	4	4	4	2	5	4	4	5	5	5	5	4		
4	4	5	4	4	2	1	2	5	5	5	5	5	4	5	5	5	4	5	5	4	1	1	1	1	1	1	4	5	5	5	5	5	5		
3	3	3	3	4	3	4	3	3	3	4	4	4	4	4	4	5	5	5	5	4	4	3	3	3	4	5	3	3	3	3	3	3	3		
3	3	3	3	3	3	3	3	3	3	3	3	3	3	3	3	3	3	3	3	3	4	4	4	3	3	4	4	4	3	3	3	3	3		
4	3	3	3	3	3	3	3	3	3	3	3	3	3	3	3	3	3	3	3	3	3	3	3	4	3	3	3	3	3	3	3	3	3		
4	4	3	4	4	5	5	5	4	5	4	5	5	5	5	5	4	4	5	5	5	4	5	5	5	5	5	4	5	4	5	5	4	4		
4	5	4	5	4	4	5	4	5	5	4	4	5	5	4	5	4	5	5	5	5	4	5	2	5	5	2	4	5	4	5	5	4	4		
3	4	5	3	4	5	5	5	5	3	3	4	5	3	4	4	5	5	5	3	4	4	4	4	5	5	5	5	5	5	5	5	5	3		
2	4	2	4	4	4	2	4	2	4	2	2	2	4	4	4	4	4	4	2	2	2	2	2	2	4	2	2	4	4	4	4	2	2		
2	4	4	4	2	4	4	4	4	5	2	2	4	5	5	4	4	4	4	5	2	4	2	4	4	4	4	4	4	4	3	2	3	3		
4	4	5	4	4	4	5	4	4	4	4	4	5	4	5	4	4	4	4	5	4	4	4	4	4	5	5	4	4	4	4	4	5	4		
4	4	5	5	5	5	4	5	5	5	5	5	3	5	4	4	5	5	4	5	3	4	4	4	4	4	4	4	2	2	4	4	4	4		
4	4	4	4	5	4	4	4	5	5	4	4	4	4	4	5	5	4	4	4	4	4	5	4	4	5	5	4	4	4	4	4	5	4		
4	4	3	4	3	4	3	4	4	4	3	4	4	3	4	4	3	4	4	3	4	4	4	4	4	4	3	4	4	4	2	1	5	5	5	
4	4	5	4	4	5	4	5	4	5	4	5	4	5	5	4	5	5	4	5	4	4	4	4	4	4	4	4	5	2	1	4	5	4	4	
3	3	4	4	4	3	4	4	4	4	4	4	4	4	5	4	4	4	4	4	3	3	4	3	3	3	4	4	3	3	3	3	4	3		
4	4	5	5	5	5	5	5	5	4	4	5	5	5	5	5	5	5	5	4	5	5	4	5	5	4	4	5	5	4	4	4	4	5		
3	3	3	3	3	3	3	3	3	3	3	3	3	3	3	3	3	3	3	3	3	3	3	3	3	3	3	3	3	3	3	3	3	3		
3	3	4	3	3	3	3	4	4	4	4	4	4	4	4	4	3	3	3	3	3	3	3	3	3	3	3	3	3	5	5	3	3	3		
5	5	5	5	5	5	5	5	5	5	5	5	5	5	5	5	5	5	5	5	5	5	5	5	5	5	5	5	5	5	5	5	5	5		
4	4	4	4	4	4	4	4	4	4	5	5	5	5	5	5	5	5	5	5	5	5	5	5	5	5	5	5	5	3	3	5	5	5	5	
4	4	5	4	4	5	5	5	5	5	4	5	5	5	5	5	5	5	5	5	5	5	5	5	5	5	5	4	5	5	5	4	5	4	4	
5	5	5	5	5	5	5	5	5	5	5	5	5	5	5	5	5	5	5	5	5	5	5	5	5	5	5	5	5	5	1	1	5	5	5	5
2	4	4	4	4	4	4	4	5	5	4	2	2	5	4	4	4	5	5	5	4	4	4	2	4	2	5	5	4	4	2	4	2	4		
4	5	4	4	5	5	5	5	4	4	5	5	5	4	4	4	4	5	5	5	4	4	5	5	4	4	5	4	2	4	4	5	5	4		
4	4	4	4	4	4	4	4	4	4	4	4	4	4	4	4	4	4	4	4	4	4	4	4	4	4	4	4	2	2	4	4	4	4	4	
3	5	5	3	5	5	4	5	5	5	4	4	5	4	5	5	5	5	5	5	5	5	5	5	5	5	5	5	4	4	5	5	5	5	5	
5	5	5	5	5	5	5	5	5	5	4	4	5	5	5	5	5	5	5	5	4	4	5	5	5	5	5	5	5	1	1	4	5	4	5	

5	4	5	5	4	4	5	4	5	4	5	4	5	4	5	5	4	5	5	5	5	4	5	5	5	5	4	5	4	5	5	4	5	4		
5	4	4	4	4	5	4	5	5	5	4	4	4	4	5	5	4	5	5	5	4	4	5	5	4	5	5	4	4	5	5	4	4	5		
1	1	1	1	2	2	1	3	2	1	1	1	1	4	2	4	4	5	3	5	1	2	1	1	1	2	2	2	2	2	2	2	2			
4	4	5	4	4	4	4	4	4	4	4	4	4	2	4	4	5	4	4	4	4	4	4	4	4	4	4	4	4	4	4	4				
3	4	4	4	5	4	3	3	4	4	3	3	4	5	5	5	5	5	5	5	2	3	4	2	3	4	3	4	4	4	3	3	3	2		
4	3	5	5	5	3	4	4	4	4	3	3	5	5	5	5	5	5	5	5	4	5	5	5	4	5	5	4	3	3	3	4	3	4		
3	5	5	5	5	5	5	5	5	5	4	4	5	5	5	5	5	5	5	5	5	5	5	5	5	5	5	5	1	1	5	5	5	5		
3	4	4	3	4	4	4	4	3	4	4	3	4	4	4	4	4	4	3	4	3	3	3	3	3	3	3	3	3	3	4	4	3	3		
4	4	4	4	4	4	4	4	4	4	3	3	4	4	4	4	4	4	4	4	4	4	4	4	4	4	4	4	5	5	4	4	4	4		
4	4	4	4	5	5	5	4	4	5	5	5	4	4	4	4	5	5	5	5	3	1	3	3	4	4	4	4	5	5	4	4	3	3		
4	3	4	5	5	5	5	5	5	5	4	5	5	4	4	5	4	4	4	5	4	2	4	3	4	3	2	2	4	4	3	3	2	2		
2	4	4	4	5	5	5	4	5	4	5	5	5	4	5	5	5	5	5	5	4	4	4	4	4	4	5	4	5	5	4	4	5	4		
3	4	5	4	5	5	5	5	5	5	4	3	5	5	5	4	5	5	5	5	4	5	5	5	5	5	5	5	1	1	4	5	3	4		
4	4	4	4	4	4	4	4	5	4	4	4	4	5	5	5	5	5	4	5	5	5	5	5	5	5	4	4	4	5	4	4	3	5		
3	3	3	3	4	5	3	3	4	3	3	4	4	4	4	4	5	4	4	4	3	4	4	4	4	4	4	4	5	5	3	4	4	4		
4	4	2	1	2	5	2	4	4	4	4	4	4	5	5	5	5	5	5	5	4	5	5	5	5	5	5	4	4	2	2	4	4	5	5	
3	3	3	3	4	4	3	3	3	3	3	3	3	2	2	4	4	4	4	4	3	2	3	3	2	3	4	3	3	5	5	2	3	2	3	
4	4	5	5	5	5	5	5	5	5	2	2	5	5	5	5	5	5	5	5	5	5	5	5	5	5	5	5	2	4	4	5	5	5	5	
3	3	4	4	4	4	4	4	4	4	3	3	3	4	4	3	3	4	4	4	3	2	3	3	3	4	3	3	5	5	4	4	4	4		
2	4	4	4	4	4	4	4	2	2	2	2	2	2	2	4	4	5	4	5	2	2	2	2	2	4	4	4	4	2	2	2	2	2		
3	3	4	4	4	4	4	4	3	4	3	3	3	5	4	4	4	5	3	5	1	2	2	2	2	4	3	4	2	2	3	3	2	1		
3	4	4	4	4	4	4	5	4	4	4	4	4	4	4	4	4	4	4	4	4	4	4	4	4	4	4	4	2	2	4	4	4	4		
3	4	4	3	4	4	2	3	4	3	4	4	4	4	4	4	4	4	4	4	2	2	4	3	3	4	4	4	5	5	3	4	3	3		
4	4	5	5	5	5	5	5	5	5	5	5	5	5	5	5	5	5	5	5	5	5	5	5	5	4	5	5	5	5	5	5	4	5		
3	4	4	4	5	5	4	5	4	4	4	3	4	4	4	5	4	4	4	4	3	2	3	3	3	4	3	3	5	5	4	4	3	3		
3	3	3	3	3	3	3	3	3	3	3	3	3	3	3	3	3	3	3	3	5	5	5	5	5	5	5	5	5	1	1	5	5	5	5	
4	4	4	4	4	4	4	4	4	4	4	4	4	4	4	4	4	4	4	4	4	4	4	4	4	4	4	4	4	5	5	4	4	4	4	
2	2	2	4	4	4	4	4	4	4	4	4	4	2	4	4	4	4	4	4	4	2	2	4	2	4	4	4	4	4	4	4	4	2	4	
3	4	4	3	4	4	4	4	4	5	4	4	5	4	4	5	4	5	4	5	4	4	4	3	4	5	5	4	4	4	4	4	5	4		
4	4	4	4	4	4	4	4	4	5	4	3	3	4	4	3	3	4	5	5	4	4	4	4	4	4	4	4	2	2	4	4	4	3		
3	5	4	5	4	4	5	5	4	3	5	5	3	3	4	4	3	2	4	5	5	3	3	3	4	4	4	5	1	2	4	4	4	4		
3	4	4	4	4	3	3	3	2	3	3	3	3	4	4	4	4	4	4	5	4	4	4	4	4	4	5	4	4	4	4	4	3	4		
4	4	4	4	4	4	4	4	4	4	4	4	4	4	4	5	5	5	5	5	4	5	5	5	5	5	5	5	3	4	5	4	3	4	3	
4	4	4	5	5	5	4	5	4	4	5	5	5	5	4	4	5	5	5	5	4	5	5	5	5	4	5	5	5	5	1	1	4	5	5	4
4	4	4	2	5	4	4	4	3	4	4	4	4	4	4	5	5	4	4	4	5	3	4	5	4	4	4	4	4	2	2	4	4	4	4	
2	2	1	2	2	1	2	2	2	2	4	4	2	1	2	2	2	2	2	1	4	4	2	3	3	2	4	4	1	1	2	2	4	3		
4	4	4	3	4	3	4	4	3	3	3	3	3	4	4	4	4	4	4	4	3	4	3	3	3	3	3	3	4	4	3	3	3	3		
4	4	4	4	4	4	4	4	4	4	5	5	5	5	5	5	5	5	5	5	5	5	5	5	5	5	5	5	5	5	5	2	2	2	2	
1	3	3	3	3	3	3	3	4	4	4	4	4	4	5	4	5	5	5	4	5	4	3	4	4	4	5	3	3	5	5	2	3	2	4	
4	3	5	3	3	4	4	4	3	4	4	4	3	5	4	5	4	5	5	5	3	4	3	3	4	5	5	4	5	5	4	5	3	3		
3	2	4	4	4	4	3	4	2	2	2	2	4	5	5	4	3	4	4	5	1	1	2	1	2	4	4	4	4	4	3	3	2	1		

4	4	4	3	4	4	4	4	4	4	4	4	4	3	4	4	4	5	5	4	5	4	4	5	5	4	4	5	4	4	4	4	4	4	5
3	4	4	4	4	5	3	4	3	4	2	2	4	5	4	4	4	5	4	5	2	4	5	4	3	5	4	4	5	3	3	4	2	3	
4	5	4	3	5	5	5	5	5	4	5	3	5	5	5	5	5	5	5	3	2	3	2	4	4	4	4	5	5	5	5	4	4		
3	4	5	5	4	5	4	4	4	4	3	4	3	5	5	4	5	5	5	2	2	4	4	5	5	5	5	4	4	4	3	4	4		
3	3	4	4	4	3	4	4	3	4	3	2	4	4	4	4	4	4	4	4	4	3	4	3	3	4	4	3	3	4	4	4	4		
4	5	4	5	4	4	5	4	4	5	4	4	4	5	5	5	4	4	5	5	5	5	5	4	4	4	4	2	5	4	4	4	4		
3	3	4	4	3	4	3	3	3	3	4	4	4	3	4	5	5	4	4	4	3	4	3	3	3	3	4	3	4	4	3	3	3	3	
5	5	4	4	5	5	5	5	5	5	4	4	4	5	5	5	5	5	5	5	5	5	5	4	4	4	4	4	4	5	5	5	4	4	5



LAMPIRAN III HASIL OLAH DATA

Model Konstruk Analisis 1

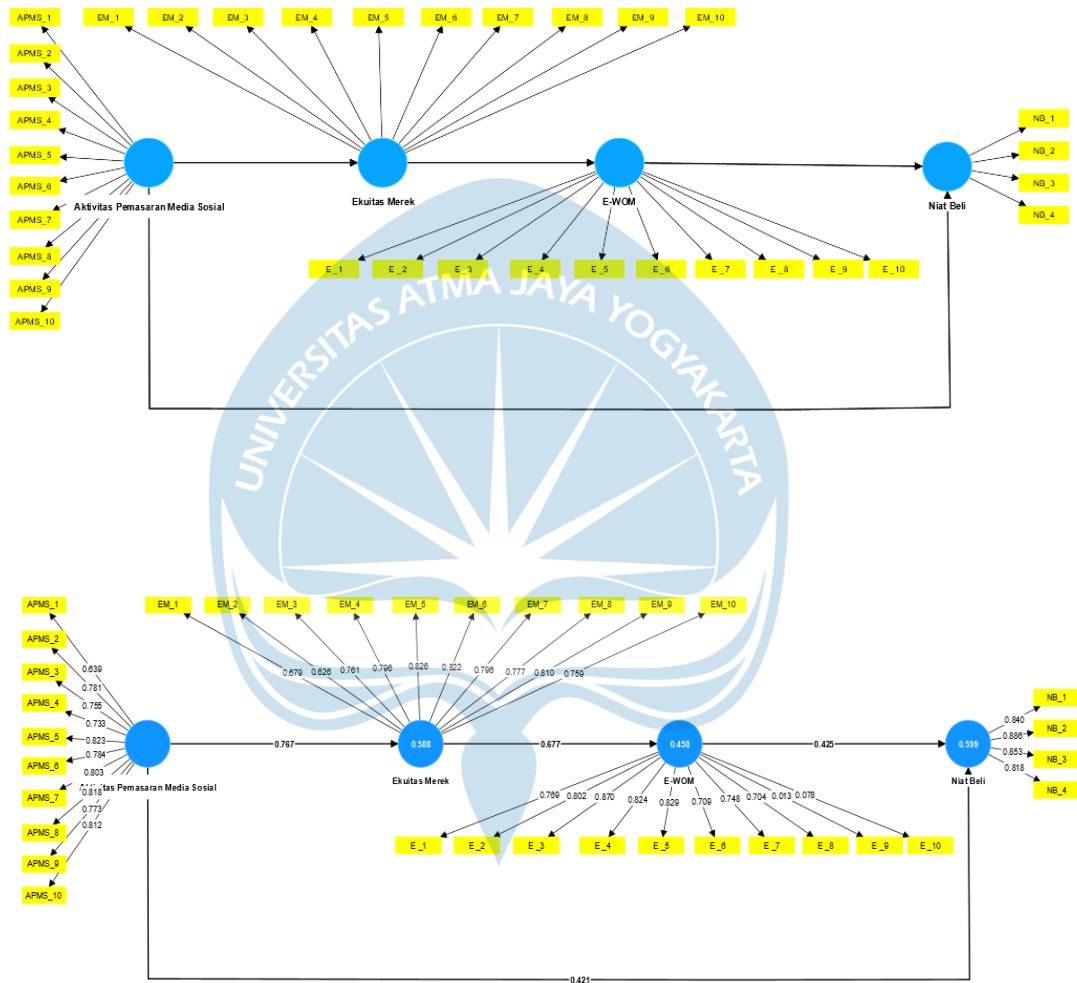

Model Konstruk Analisis Ulang

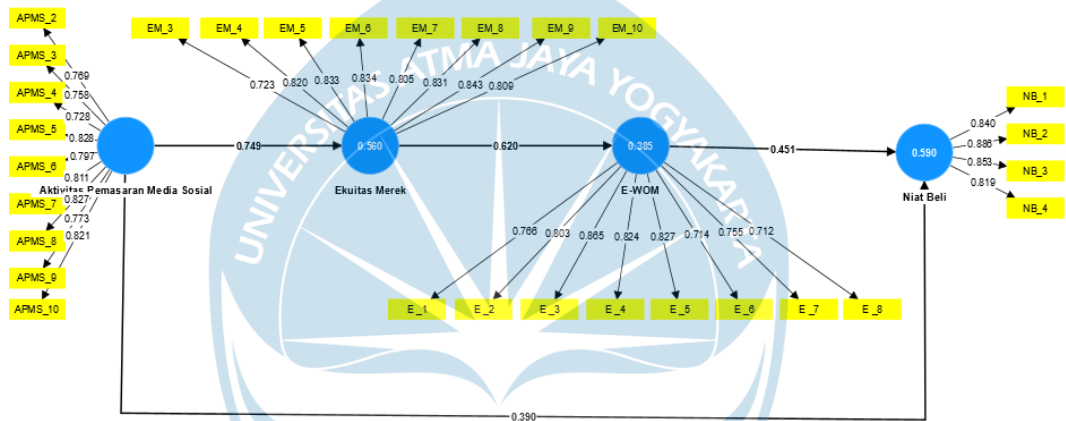
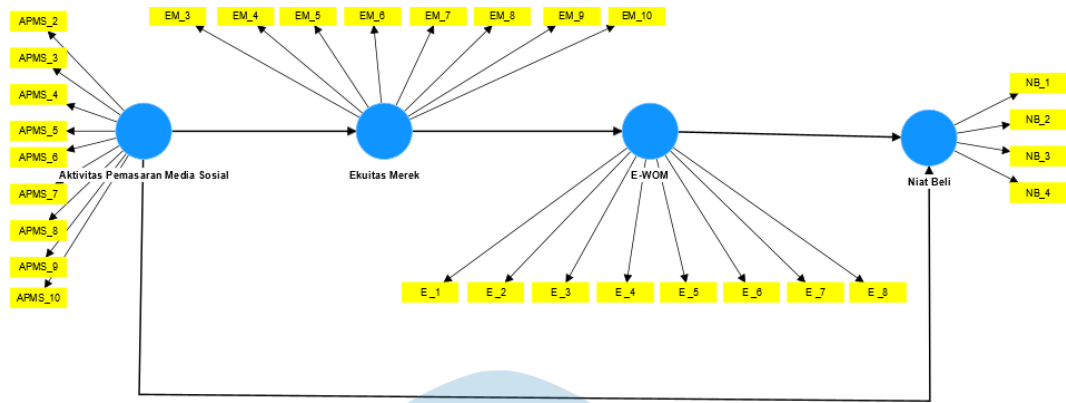

Hasil Bootstrapping

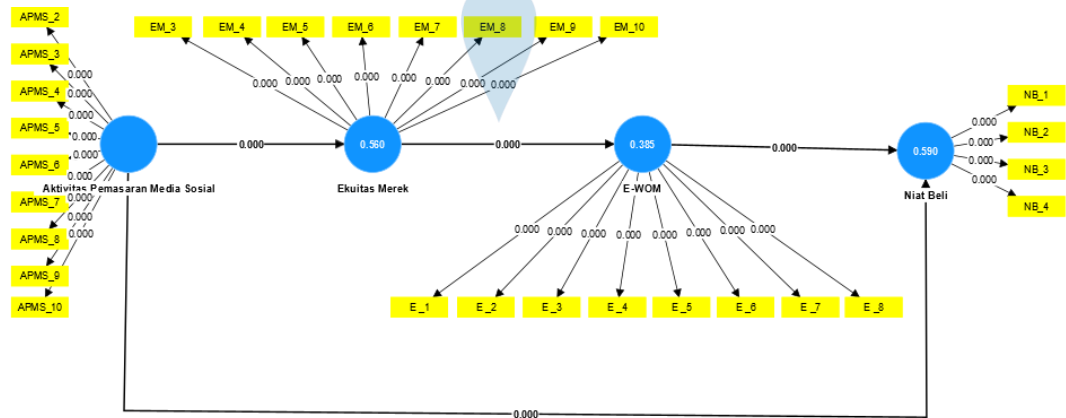

Hasil Outer Loading

Outer loadings - Matrix Zoom (72%)

	Aktivitas Pemasaran Media Sosial	E-WOM	Ekuitas Merek	Niat Beli
APMS_10	0.821			
APMS_2	0.769			
APMS_3	0.758			
APMS_4	0.728			
APMS_5	0.828			
APMS_6	0.797			
APMS_7	0.811			
APMS_8	0.827			
APMS_9	0.773			
E_1		0.768		
E_2		0.803		
E_3		0.865		
E_4		0.824		
E_5		0.827		
E_6		0.714		
E_7		0.755		
E_8		0.712		
EM_10			0.809	
EM_3			0.723	
EM_4			0.820	
EM_5			0.833	
EM_6			0.834	
EM_7			0.805	
EM_8			0.831	
EM_9			0.843	
NB_1				0.840
NB_2				0.886
NB_3				0.853
NB_4				0.819

Hasil AVE, Cronbach's Alpha, Composite Reliability

Construct reliability and validity - Overview Zoom (72%)

	Cronbach's alpha	Composite reliability (rho_a)	Composite reliability (rho_c)	Average variance extracted (AVE)
Aktivitas Pemasaran Media Sosial	0.925	0.927	0.938	0.628
E-WOM	0.910	0.914	0.827	0.616
Ekuitas Merek	0.928	0.927	0.940	0.661
Niat Beli	0.871	0.873	0.912	0.722

Hasil R-Square dan R-Square adjusted

R-square - Overview Zoom (130%)

	R-square	R-square adjusted
E-WOM	0.385	0.382
Ekuitas Merek	0.560	0.559
Niat Beli	0.590	0.587

Hasil Cross Loading

Discriminant validity - Cross loadings Zoom (75%)

	Aktivitas Pemasaran Media Sosial	E-WOM	Ekuitas Merek	Niat Beli
APMS_10	0.821	0.535	0.649	0.622
APMS_2	0.769	0.562	0.538	0.567
APMS_3	0.758	0.521	0.598	0.494
APMS_4	0.728	0.518	0.482	0.518
APMS_5	0.828	0.499	0.631	0.580
APMS_6	0.797	0.483	0.625	0.525
APMS_7	0.811	0.573	0.588	0.492
APMS_8	0.827	0.523	0.631	0.520
APMS_9	0.773	0.533	0.570	0.604
E_1	0.497	0.768	0.416	0.614
E_2	0.473	0.803	0.430	0.572
E_3	0.563	0.865	0.559	0.632
E_4	0.504	0.824	0.457	0.632
E_5	0.583	0.827	0.522	0.589
E_6	0.520	0.714	0.541	0.439
E_7	0.514	0.755	0.487	0.475
E_8	0.509	0.712	0.481	0.482
EM_10	0.583	0.413	0.809	0.333
EM_3	0.634	0.575	0.723	0.552
EM_4	0.576	0.483	0.820	0.405
EM_5	0.640	0.563	0.833	0.480
EM_6	0.614	0.510	0.834	0.467
EM_7	0.622	0.529	0.805	0.502
EM_8	0.568	0.448	0.831	0.380
EM_9	0.626	0.475	0.843	0.450
NB_1	0.630	0.531	0.473	0.840
NB_2	0.668	0.585	0.556	0.886
NB_3	0.503	0.602	0.361	0.853
NB_4	0.538	0.691	0.484	0.819

Hasil Path Coefficient

Path coefficients - Mean, STDEV, T values, p values Zoom (75%)

	Original sample (O)	Sample mean (M)	Standard deviation (STDEV)	T statistics (O/STDEVI)	P values
Aktivitas Pemasaran Media Sosial -> Ekuitas Merek	0.749	0.750	0.030	25.269	0.000
Aktivitas Pemasaran Media Sosial -> Niat Beli	0.390	0.389	0.070	5.570	0.000
E-WOM -> Niat Beli	0.451	0.453	0.083	5.437	0.000
Ekuitas Merek -> E-WOM	0.620	0.624	0.042	14.929	0.000