

BAB V

KESIMPULAN

5.1 Perancangan Struktur Atas

Setelah dilakukan perhitungan pada perancangan Gedung Pengelola Taman Rekreasi Samarinda, didapatkan kesimpulan sebagai berikut :

1. Pada atap digunakan satu jenis rangka kuda-kuda dengan material baja. Pada elemen tepi rangka kuda-kuda menggunakan profil 2L x 60 x 60 x 6, sedangkan untuk elemen tegak dan diagonal menggunakan profil 2L x 50 x 50 x 5.
2. Pada pelat digunakan tebal 120 mm.
3. Pada balok digunakan delapan tipe balok, B1 400 x 800, B2 400 x 700, RB 300 x 550 (Ring Balok), S 250 x 450 (Sloof), BA 300 x 550 (Balok Anak), BL 250 x 600 (Balok Lisplang), BK 400 x 600 (Balok Kantilever), dan BB 250 x 350 (Balok Bordes). Detail penulangan balok terdapat pada Lampiran B.1.
4. Pada kolom digunakan dua tipe kolom silinder, K1 900 dan K2 750.

5.2 Perancangan Struktur Bawah

Setelah dilakukan perhitungan pada perancangan Gedung Pengelola Taman Rekreasi Samarinda, didapatkan kesimpulan sebagai berikut:

1. Berdasarkan pengujian tanah di lapangan, ada tiga jenis lapisan tanah pada area pembangunan Gedung Pengelola Taman Rekreasi Samarinda. Lempung berpasir dan berlumpur pada kedalaman 0 m sampai -8,4 m, pasir pada kedalaman -8,4 m sampai -11 m, kerikil pada kedalaman -11 m sampai -15,6 m.
2. Digunakan pondasi tiang dengan metode pancang, ujung tiang pada kedalaman 12 m dengan tiga tipe *pile cap*. Sebelum penentuan pondasi dalam dengan panjang tiang 12 m, telah dilakukan *trial* pada pondasi dangkal yang dapat dilihat di bab 3.
3. Pada titik pondasi dengan beban terbesar terjadi penurunan tanah sebesar 1,65 cm.
4. Berdasarkan nilai $FS > 1$, maka tanah tidak berpotensi mengalami likuifaksi.
5. Detail Penulangan *Pile Cap* terdapat pada Lampiran B.1.

5.3 Perencanaan Biaya dan Waktu

Setelah dilakukan perhitungan pada perancangan Gedung Pengelola Taman Rekreasi Samarinda, didapatkan kesimpulan sebagai berikut:

1. Total biaya pembangunan Gedung Pengelola Taman Rekreasi Samarinda sebesar Rp 10.438.957.043,92 sudah termasuk PPN 11 % dengan harga bangunan per m² sebesar Rp 4.744.980,47.
2. Pembangunan Gedung Pengelola Taman Rekreasi Samarinda dibutuhkan durasi selama 288 hari.



DAFTAR PUSTAKA

- Badan Standarisasi Nasional, 2020. *Beban Desain Minimum dan Kriteria terkait untuk Bangunan Gedung dan Struktur Lain (SNI 1727:2020)*.
- Badan Standarisasi Nasional, 2019. *Perencanaan Ketahanan Gempa (SNI 1726:2019)*.
- Badan Standarisasi Nasional, 2019. *Persyaratan Beton Struktural untuk Bangunan Gedung (SNI 2847:2019)*.
- Badan Standarisasi Nasional, 2017. *Persyaratan Perancangan Geoteknik (SNI 8460:2017)*.
- Badan Standarisasi Nasional, 2017. *Spesifikasi untuk Bangunan Gedung Baja Struktural (SNI 1729:2020)*.
- Farichah, H., & Kumala Sari, P. T. (2019). Analisis Potensi Likuifaksi dengan Metode Deterministik di Wilayah Surabaya. *Reka Buana : Jurnal Ilmiah Teknik Sipil Dan Teknik Kimia*, 4(1), 68. <https://doi.org/10.33366/rekabuana.v4i1.1195>.
- Peraturan Menteri PUPR No. 1 Tahun 2022 tentang Pedoman Penyusunan Perkiraan Biaya Pekerjaan Konstruksi Pekerjaan Umum dan Perumahan Rakyat.
- Peraturan Menteri PUPR No. 28/PRT/M Tahun 2016 tentang Pedoman Analisis Harga Satuan Pekerjaan Bidang Pekerjaan Umum.
- Yuliawan, E., & Rahayu, T. (2018). Analisis Daya Dukung Dan Penurunan Pondasi Tiang Berdasarkan Pengujian Spt Dan Cyclic Load Test. *Jurnal Konstruksi a*, 9(2).



LAMPIRAN

Lampiran A.1. Gambar Pemodelan ETABS

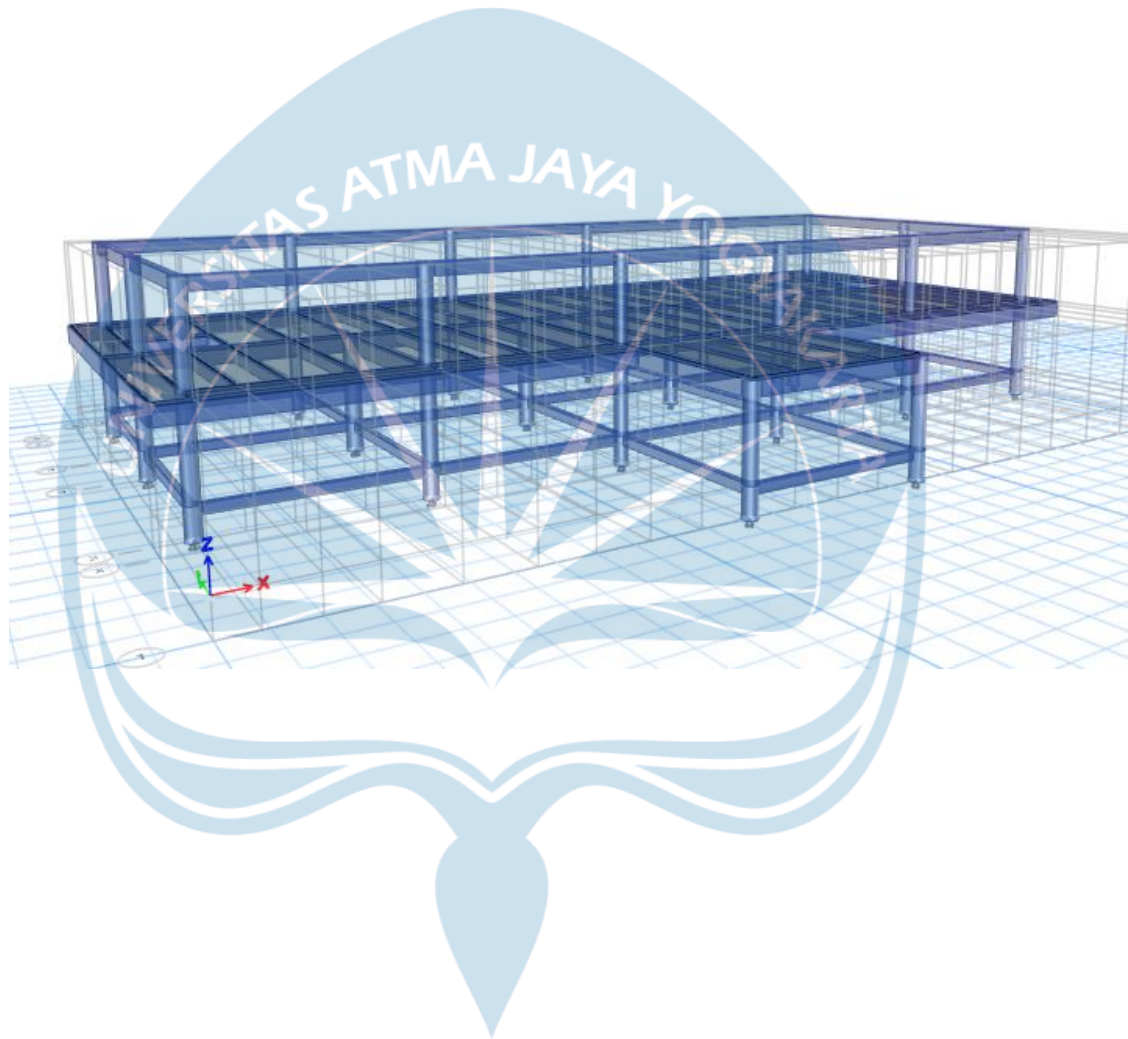

Lampiran A.2. Rekapitulasi Gaya Dalam Balok dan Kolom

Balok

Klasifikasi Balok

Balok Induk 1	:	10 m
Balok Induk 2	:	10 m
Balok Anak	:	10 m
Ring Balk	:	10 m
Sloof	:	10 m
Balok Lisplang	:	10 m
Balok Kantilever	:	1,5 m

Rekap Gaya Dalam Balok

Balok	Gaya Momen Positif (kNm)		Gaya Momen Negatif (kNm)		Gaya Geser (V2E) (kN)
	Tumpuan	Lapangan	Tumpuan	Lapangan	
B1	781,667	781,667	1033,207	502,685	378,8
B2	368,91	368,6	553,031	250,197	194
BA	188,812	173,424	324,817	101,353	105
RB	120,21	120,207	129,829	97,414	25,5
S	16,326	15,929	40,45	10,635	15,54
BL	224,367	224,367	177,67	177,67	147
BK	182,067	137,58	239,054	100,486	74,17

Rekap Gaya Dalam Kolom

		K1	K2
Pu (Kn)		2050,3499	1907,7681
Mu (Kn)	My	120,4399	338,7188
	Mx	184,7579	524,163
Ve (Knm)		56,6519	100,0382

Lampiran A.3. Data Tanah

2,5 TON CONE PENETRATION TEST

LOCATION :
 NUMBER OF CPT. : 1
 ELEVATION : -1,00 m dari muka jalan
 G.WATER DEPTH : -3,00 meter dari muka tanah
 DATE :
 WEATHER : Cerah
 SURVEYOR :
 PROJECT :

Depth meters	C kg/cm ²	C+F kg/cm ²	LF kg/cm ²	TF kg/cm ¹	Σ TF kg/cm ¹	Depth meters	C kg/cm ²	C+F kg/cm ²	LF kg/cm ²	TF kg/cm ¹	Σ TF kg/cm ¹
0,00	0	0	0,00								
0,20	2	4	0,20	4	4	10,20	28	31	0,30	6	264
0,40	5	7	0,20	4	8	10,40	33	36	0,30	6	270
0,60	8	10	0,20	4	12	10,60	30	33	0,30	6	276
0,80	11	14	0,30	6	18	10,80	34	37	0,30	6	282
1,00	28	31	0,30	6	24	11,00	32	35	0,30	6	288
1,20	43	46	0,30	6	30	11,20	46	49	0,30	6	294
1,40	15	18	0,30	6	36	11,40	51	54	0,30	6	300
1,60	19	21	0,20	4	40	11,60	74	77	0,30	6	306
1,80	8	10	0,20	4	44	11,80	68	71	0,30	6	312
2,00	6	8	0,20	4	48	12,00	76	79	0,30	6	318
2,20	3	5	0,20	4	52	12,20	89	92	0,30	6	324
2,40	4	6	0,20	4	56	12,40	93	96	0,30	6	330
2,60	7	9	0,20	4	60	12,60	104	107	0,30	6	336
2,80	5	7	0,20	4	64	12,80	115	118	0,30	6	342
3,00	2	4	0,20	4	68	13,00	108	111	0,30	6	348
3,20	6	8	0,20	4	72	13,20	125	129	0,30	6	354
3,40	9	11	0,20	4	76	13,40	141	143	0,20	4	358
3,60	10	13	0,30	6	82	13,60	133	136	0,30	6	364
3,80	7	9	0,20	4	86	13,80	138	141	0,30	6	370
4,00	5	7	0,20	4	90	14,00	146	149	0,30	6	376
4,20	11	14	0,30	6	96	14,20	162	165	0,30	6	382
4,40	13	16	0,30	6	102	14,40	179	182	0,30	6	388
4,60	12	15	0,30	6	108	14,60	184	187	0,30	6	394
4,80	14	17	0,30	6	114	14,80	196	199	0,30	6	400
5,00	11	14	0,30	6	120	15,00	208	211	0,30	6	406
5,20	8	10	0,20	4	124	15,20	224	227	0,30	6	412
5,40	13	16	0,30	6	130	15,40	246	250	0,40	8	420
5,60	21	24	0,30	6	136	15,60	250	250	0,00	0	420
5,80	19	22	0,30	6	142	15,80					
6,00	14	17	0,30	6	148	16,00					
6,20	10	13	0,30	6	154	16,20					
6,40	7	9	0,20	4	158	16,40					
6,60	16	19	0,30	6	164	16,60					
6,80	12	15	0,30	6	170	16,80					
7,00	11	14	0,30	6	176	17,00					
7,20	8	10	0,20	4	180	17,20					
7,40	6	8	0,20	4	184	17,40					
7,60	5	7	0,20	4	188	17,60					
7,80	3	5	0,20	4	192	17,80					
8,00	9	12	0,30	6	198	18,00					
8,20	11	14	0,30	6	204	18,20					
8,40	13	16	0,30	6	210	18,40					
8,60	17	20	0,30	6	216	18,60					
8,80	22	25	0,30	6	222	18,80					
9,00	26	29	0,30	6	228	19,00					
9,20	31	34	0,30	6	234	19,20					
9,40	35	38	0,30	6	240	19,40					
9,60	29	32	0,30	6	246	19,60					
9,80	24	27	0,30	6	252	19,80					
10,00	23	26	0,30	6	258	20,00					



2,5 TON CONE PENETRATION TEST

Project :
Number of cpt. : 1
Date :

Elevation : -1,00 m dari muka jalan
G.Water Depth : -3,00 meter dari muka tanah

fa	5	10	15	20	25	Kg/cm ²
qc	50	100	150	200	250	Kg/cm ²
tf	500	1000	1500	2000	2500	Kg/cm ²

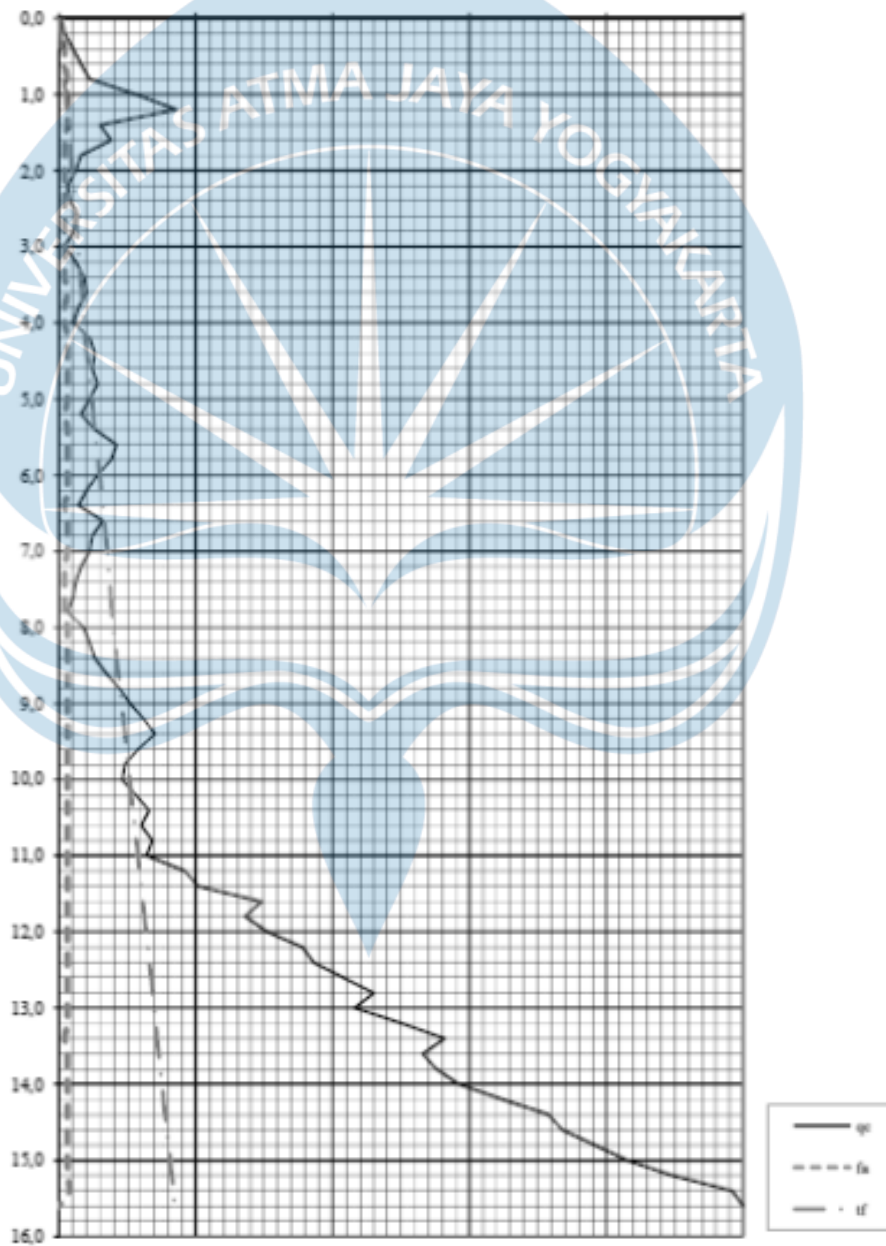



2,5 TON CONE PENETRATION TEST

LOCATION :
NUMBER OF CPT. : 3
ELEVATION : -1,00 m dari muka jalan
G.WATER DEPTH : -3,00 meter dari muka tanah

DATE :
WEATHER :
SURVEYOR :
PROJECT :

Depth meters	C	C+F	LF	TF	Σ TF	Depth meters	C	C+F	LF	TF	Σ TF
	kg/cm ²	kg/cm ²	kg/cm ²	kg/cm'	kg/cm'		kg/cm ²	kg/cm ²	kg/cm ²	kg/cm'	kg/cm'
0,00	0	0	0,00								
0,20	2	4	0,20	4	4	10,20	39	42	0,30	6	280
0,40	4	6	0,20	4	8	10,40	34	37	0,30	6	288
0,60	7	9	0,20	4	12	10,60	41	44	0,30	6	292
0,80	12	15	0,30	6	18	10,80	46	49	0,30	6	298
1,00	18	19	0,30	6	24	11,00	63	66	0,30	6	304
1,20	24	27	0,30	6	30	11,20	58	61	0,30	6	310
1,40	18	21	0,30	6	36	11,40	64	67	0,30	6	316
1,60	14	17	0,30	6	42	11,60	72	75	0,30	6	322
1,80	10	13	0,30	6	48	11,80	74	77	0,30	6	328
2,00	7	9	0,20	4	52	12,00	86	89	0,30	6	334
2,20	4	6	0,20	4	56	12,20	78	81	0,30	6	340
2,40	5	7	0,20	4	60	12,40	84	87	0,30	6	346
2,60	8	10	0,20	4	64	12,60	92	95	0,30	6	352
2,80	11	14	0,30	6	70	12,80	103	106	0,30	6	358
3,00	9	11	0,20	4	74	13,00	115	118	0,30	6	364
3,20	6	8	0,20	4	78	13,20	124	127	0,30	6	370
3,40	8	10	0,20	4	82	13,40	120	123	0,30	6	376
3,60	12	15	0,30	6	88	13,60	126	129	0,30	6	382
3,80	11	14	0,30	6	94	13,80	135	138	0,30	6	388
4,00	6	8	0,20	4	98	14,00	141	144	0,30	6	394
4,20	13	16	0,30	6	104	14,20	169	172	0,30	6	400
4,40	15	18	0,30	6	110	14,40	153	156	0,30	6	406
4,60	14	17	0,30	6	116	14,60	164	167	0,30	6	412
4,80	11	14	0,30	6	122	14,80	178	181	0,30	6	418
5,00	8	10	0,20	4	128	15,00	196	199	0,30	6	424
5,20	10	13	0,30	6	132	15,20	214	217	0,30	6	430
5,40	14	17	0,30	6	138	15,40	246	250	0,40	8	438
5,60	18	21	0,30	6	144	15,60	250	250	0,00	0	438
5,80	16	18	0,20	4	148	15,80					
6,00	24	27	0,30	6	154	16,00					
6,20	28	29	0,30	6	160	16,20					
6,40	32	35	0,30	6	166	16,40					
6,60	25	28	0,30	6	172	16,60					
6,80	23	26	0,30	6	178	16,80					
7,00	18	21	0,30	6	184	17,00					
7,20	20	23	0,30	6	190	17,20					
7,40	16	19	0,30	6	196	17,40					
7,60	22	25	0,30	6	202	17,60					
7,80	26	29	0,30	6	208	17,80					
8,00	31	34	0,30	6	214	18,00					
8,20	35	38	0,30	6	220	18,20					
8,40	39	42	0,30	6	226	18,40					
8,60	40	43	0,30	6	232	18,60					
8,80	36	39	0,30	6	238	18,80					
9,00	34	37	0,30	6	244	19,00					
9,20	32	35	0,30	6	250	19,20					
9,40	33	36	0,30	6	256	19,40					
9,60	41	44	0,30	6	262	19,60					
9,80	46	49	0,30	6	268	19,80					
10,00	48	51	0,30	6	274	20,00					

2,5 TON CONE PENETRATION TEST

Project :
Number of cpt. : 3
Date :

Elevation : -1,00 m dari muka jalan
G. Water Depth : -3,00 meter dari muka tanah

fa	5	10	15	20	25	Kg/cm ²
qc	50	100	150	200	250	Kg/cm ²
tf	500	1000	1500	2000	2500	Kg/cm ²

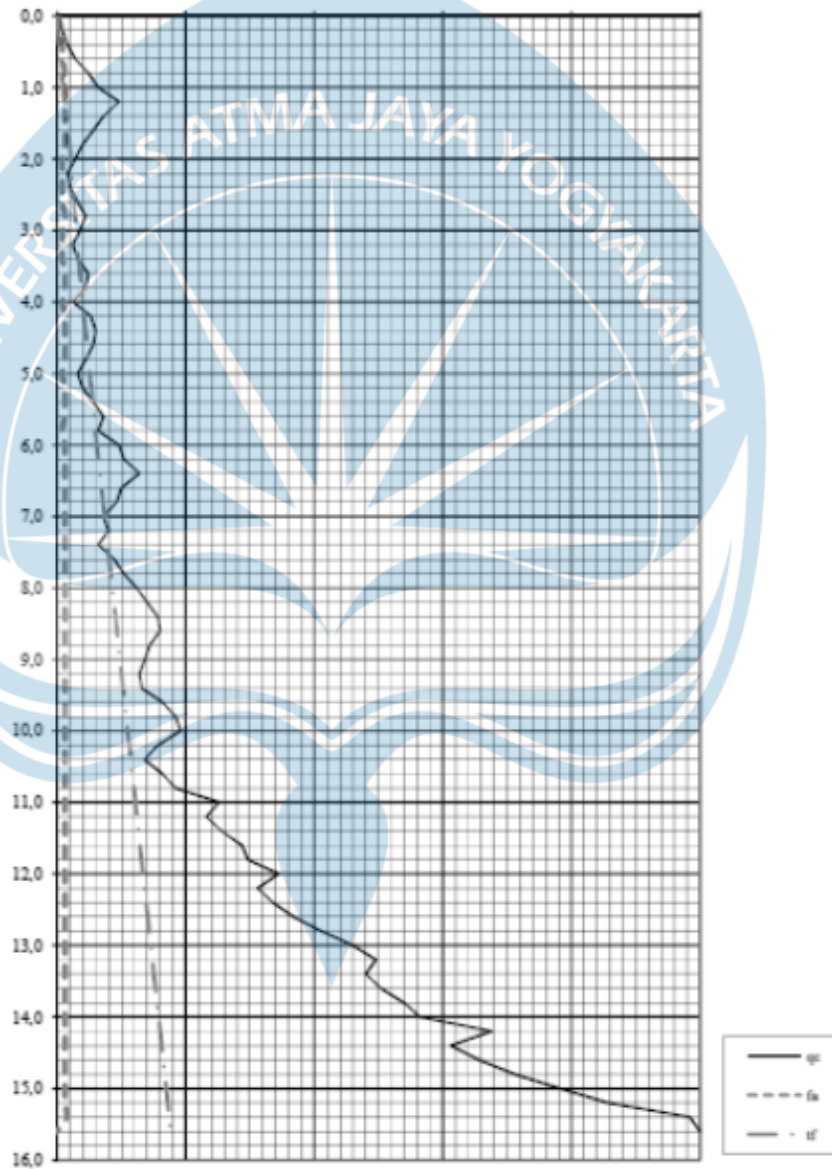

2,5 TON CONE PENETRATION TEST

LOCATION	DATE
NUMBER OF CPT. : 4	WEATHER
ELEVATION : -1,00 m dari muka jalan	SURVEYOR
G.WATER DEPTH : -3,00 meter dari muka tanah	PROJECT

Depth meters	C	C+F	LF	TF	Σ	Depth meters	C	C+F	LF	TF	Σ
	kg/cm ²	kg/cm ²	kg/cm ²	kg/cm'	TF		kg/cm ²	kg/cm ²	kg/cm ²	kg/cm'	TF
0,00	0	0	0,00								
0,20	3	4	0,10	2	2	10,20	46	49	0,30	6	266
0,40	4	6	0,20	4	6	10,40	52	55	0,30	6	282
0,60	6	8	0,20	4	10	10,60	61	64	0,30	6	298
0,80	11	14	0,30	6	16	10,80	68	71	0,30	6	304
1,00	18	21	0,30	6	22	11,00	63	65	0,20	4	308
1,20	23	26	0,30	6	28	11,20	59	62	0,30	6	314
1,40	29	32	0,30	6	34	11,40	54	57	0,30	6	320
1,60	25	28	0,30	6	40	11,60	61	64	0,30	6	326
1,80	14	17	0,30	6	46	11,80	68	71	0,30	6	332
2,00	9	12	0,30	6	52	12,00	89	92	0,30	6	338
2,20	6	8	0,20	4	56	12,20	102	105	0,30	6	344
2,40	7	9	0,20	4	60	12,40	116	119	0,30	6	350
2,60	14	17	0,30	6	66	12,60	108	111	0,30	6	356
2,80	16	19	0,30	6	72	12,80	101	104	0,30	6	362
3,00	12	15	0,30	6	78	13,00	92	95	0,30	6	368
3,20	8	10	0,20	4	82	13,20	105	108	0,30	6	374
3,40	11	14	0,30	6	88	13,40	119	122	0,30	6	380
3,60	16	19	0,30	6	94	13,60	136	139	0,30	6	386
3,80	18	21	0,30	6	100	13,80	145	148	0,30	6	392
4,00	14	17	0,30	6	106	14,00	138	141	0,30	6	398
4,20	11	14	0,30	6	112	14,20	143	146	0,30	6	404
4,40	13	16	0,30	6	118	14,40	156	159	0,30	6	410
4,60	10	13	0,30	6	124	14,60	163	165	0,20	4	414
4,80	8	10	0,20	4	128	14,80	179	182	0,30	6	420
5,00	6	8	0,20	4	132	15,00	191	194	0,30	6	426
5,20	7	9	0,20	4	136	15,20	225	228	0,30	6	432
5,40	10	13	0,30	6	142	15,40	246	250	0,40	8	440
5,60	14	17	0,30	6	148	15,60	250	250	0,00	0	440
5,80	19	22	0,30	6	154	15,80					
6,00	21	24	0,30	6	160	16,00					
6,20	26	29	0,30	6	166	16,20					
6,40	23	26	0,30	6	172	16,40					
6,60	21	24	0,30	6	178	16,60					
6,80	24	27	0,30	6	184	16,80					
7,00	16	19	0,30	6	190	17,00					
7,20	14	17	0,30	6	196	17,20					
7,40	12	15	0,30	6	202	17,40					
7,60	17	20	0,30	6	208	17,60					
7,80	24	27	0,30	6	214	17,80					
8,00	28	31	0,30	6	220	18,00					
8,20	36	39	0,30	6	226	18,20					
8,40	43	46	0,30	6	232	18,40					
8,60	48	51	0,30	6	238	18,60					
8,80	44	47	0,30	6	244	18,80					
9,00	35	38	0,30	6	250	19,00					
9,20	41	44	0,30	6	256	19,20					
9,40	49	52	0,30	6	262	19,40					
9,60	63	66	0,30	6	268	19,60					
9,80	54	57	0,30	6	274	19,80					
10,00	52	55	0,30	6	280	20,00					



2,5 TON CONE PENETRATION TEST

Project :
Number of cpt. : 4
Date :

Elevation : -1,00 m dari muka jalan
G.Water Depth : -3,00 meter dari muka tanah

fa	5	10	15	20	25	Kg/cm ²
qc	50	100	150	200	250	Kg/cm ²
tf	500	1000	1500	2000	2500	Kg/cm ¹

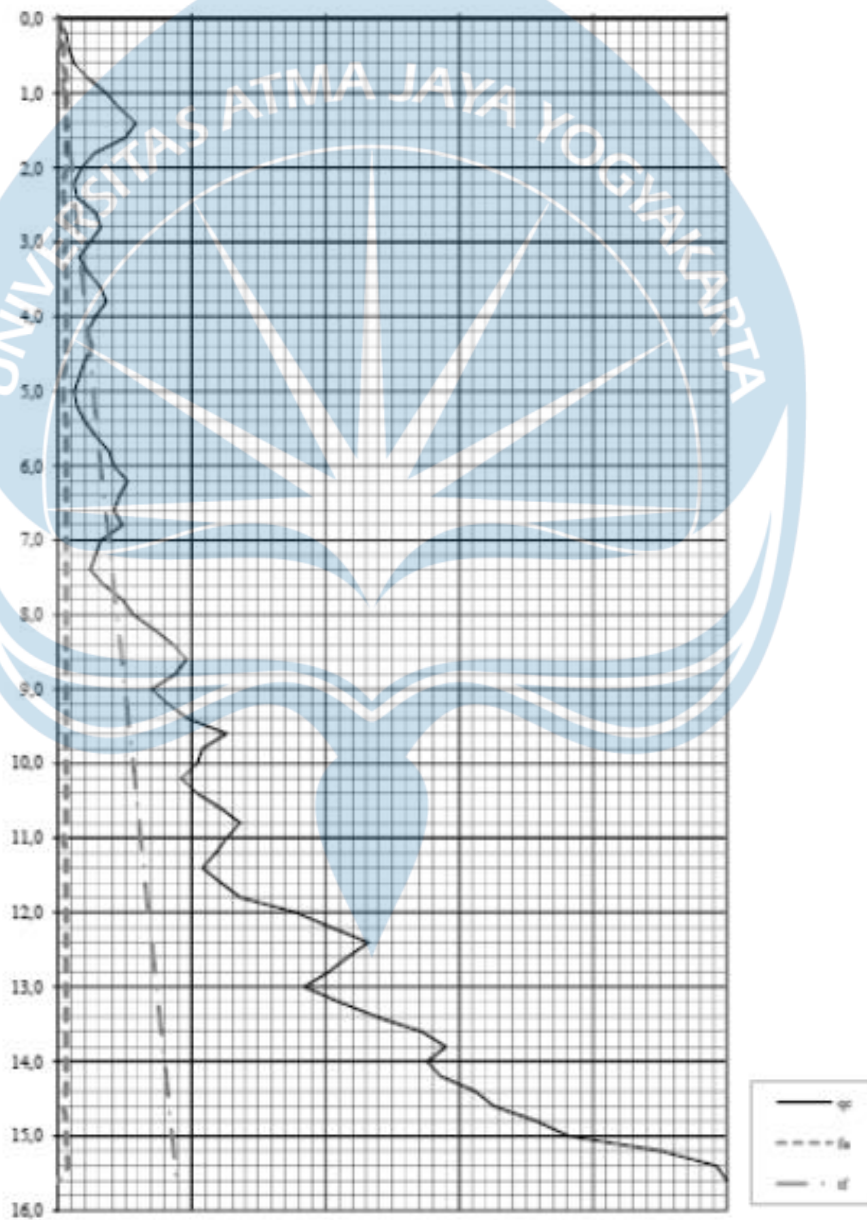



SOIL MECHANIC LABORATORY
CIVIL ENGINEERING PROGRAM
FACULTY OF ENGINEERING, UIAY
44 BABARSARI STREET, YOGYAKARTA 55281
Tel: +62-274-487711 ext. 1055
Fax: +62-274-487748

Boring Number:

BH-1

BOR LOG

CLIENT:	PROJECT TITLE :
PROJECT CONTRACT NUMBER:	PROJECT LOCATION :
DATE STARTED:	GROUND ELEVATION : -1,00 m from road level
DATE COMPLETED:	HOLE SIZE : 7.295cm
DRILLING CONTRACTOR: SOIL MECH. LAB. UIAY	GROUND WATER LEVEL : -3,00 m from ground level
DRILLING METHOD: ROTARY SPINDLE, SKID MOUNTED TYPE	WEATHER CONDITION : FINE
LOGGED BY: MUKAROH, CS.	ESTIMATED SEASONAL HIGH : -
CHECKED BY: SOIL MECH. LAB. UIAY	

Depth (m)	Graph Log	Material Description (field observations)	Contact Depth (m)	Sample Number	Blow Counts (N Value)				Water Level Elevation (m)	SPT Value									
					N1	N2	N3	NV		0	10	20	30	40	50	60			
1																			
2						1	1	1	2										
3		Lanau (hitam)	6			1	1	3	4	-1.00									
4						1	1	3	4										
5				I															
6						2	2	5	7										
7						2	4	3	7										
8						2	4	6	10										
9		Lanau (hijau)	8	II		2	4	6	10										
10						3	6	6	12										
11						3	6	6	12										
12						3	7	8	15										
13						3	7	8	15										
14						6	9	15	24										
15		Pasir halus (coklat, abu-abu)	5			6	9	15	24										
16						6	11	33	44										
17						6	11	33	44										
18						7	11	21	32										
19						7	11	21	32										
20						6	8	9	17										
21						6	8	9	17										
22						7	6	12	18										
23						7	6	12	18										
24		Pasir (coklat, abu-abu)	11			6	7	10	17										
25						6	7	10	17										
26						6	7	10	17										
27						6	12	12	24										
28						6	12	12	24										
29						8	12	18	30										
30						8	12	18	30										

Catatan: Pada pengamatan di lapangan, lanau bisa tampak seperti pasir halus atau pasir sangat halus

REKAP HASIL PENGUJIAN TANAH

Proyek : A
Lokasi : Jl. /
Tanggal : 13. / 7

Titik	Kedalaman (m)	Kadar Air (%)	Berat Jenis (G)	γ_b (gr/cm ³)	γ_k (gr/cm ³)	Pengujian Geser Langsung	
						c (kg/cm ²)	θ'
BH 1	5,00	48,77	2,37	1,52	1,02	0,00	12,61
	10,00	48,54	2,38	1,51	1,02	0,00	12,40

ANALISA BUTIRAN

Proyek :
Lokasi :
Tanggal :

Titik : BH 1
Kedalaman: 5

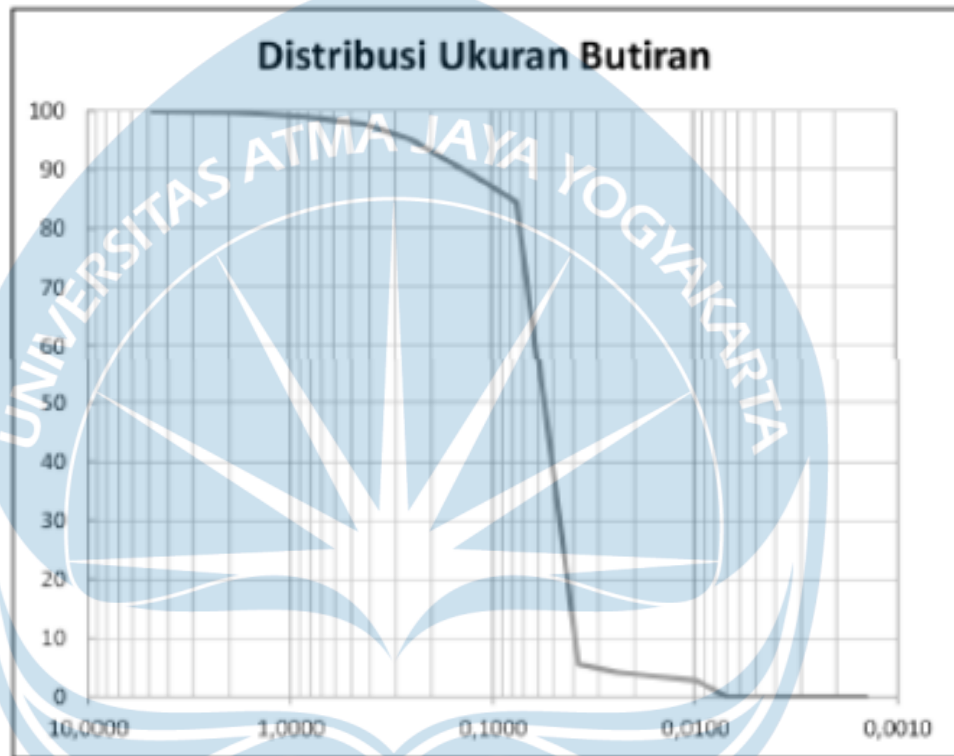

No. Sieve	Ukuran Butiran (mm)	Berat Tertahan	Berat Lolos	Prosen Lolos
4	4,750	0,00	100,00	100,00
10	2,000	0,17	99,83	99,83
20	0,850	0,85	98,98	98,98
40	0,425	1,28	97,70	97,70
60	0,250	2,54	95,16	95,16
140	0,106	7,44	87,72	87,72
200	0,075	3,27	84,45	84,45
Pan		84,45		

ANALISA BUTIRAN

Proyek :

Lokasi :

Tanggal :

Titik : BH 1

Kedalaman: 10

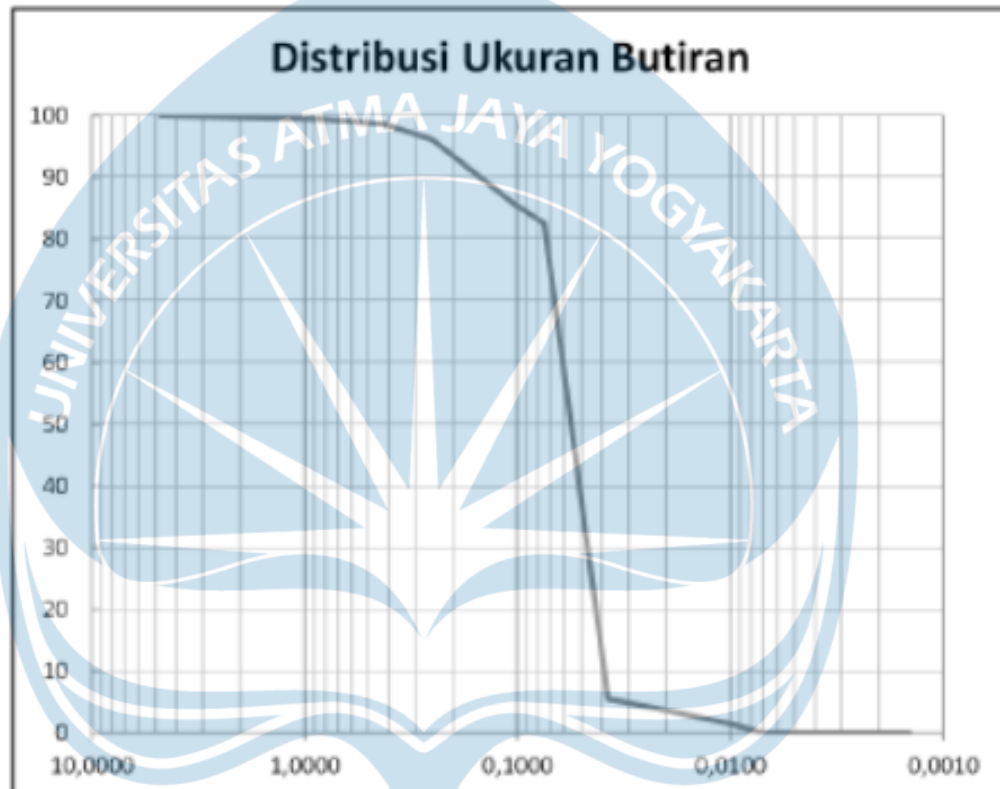

No. Sieve	Ukuran Butiran (mm)	Berat Tertahan	Berat Lolos	Prosen Lolos
4	4,750	0,00	100,00	100,00
10	2,000	0,27	99,73	99,73
20	0,850	0,36	99,37	99,37
40	0,425	0,79	98,58	98,58
60	0,250	2,51	96,07	96,07
140	0,106	10,13	85,94	85,94
200	0,075	3,49	82,45	82,45
Pan		82,45		



SOIL MECHANICS LABORATORY
DEPARTMENT OF CIVIL ENGINEERING
FACULTY OF ENGINEERING - ATMA JAYA YOGYAKARTA UNIVERSITY

10 TON DUTCH CONE PENETRATION TEST

Location : _____
No. of CPT : SB. 1 Weather : Cerah
Elevation : +1,00 meter dari muka jalan Surveyor : _____
Ground Water Depth : +1 5,00 meter dari muka tanah Project : _____

Kedalaman meter	C kg/cm ²	C + F Kg/cm ²	LF Kg/cm ²	TF Kg/cm ¹	Jumlah TF Kg/cm ¹	Kedalaman meter	C kg/cm ²	C + F Kg/cm ²	LF Kg/cm ²	TF Kg/cm ¹	Jumlah TF Kg/cm ¹
0,00	0	0	0,00	0	0						
0,20	4	8	0,30	8	8	10,20					
0,40	6	8	0,30	8	12	10,40					
0,60	9	11	0,30	8	18	10,60					
0,80	13	18	0,45	9	27	10,80					
1,00	18	21	0,45	9	36	11,00					
1,20	34	37	0,45	9	45	11,20					
1,40	69	72	0,45	9	54	11,40					
1,60	93	96	0,45	9	63	11,60					
1,80	168	171	0,45	9	72	11,80					
2,00	237	240	0,45	9	81	12,00					
2,20	298	301	0,45	9	90	12,20					
2,40	354	357	0,45	9	99	12,40					
2,60	396	399	0,45	9	108	12,60					
2,80	446	450	0,60	12	120	12,80					
3,00						13,00					
3,20						13,20					
3,40						13,40					
3,60						13,60					
3,80						13,80					
4,00						14,00					
4,20						14,20					
4,40						14,40					
4,60						14,60					
4,80						14,80					
5,00						15,00					
5,20						15,20					
5,40						15,40					
5,60						15,60					
5,80						15,80					
6,00						16,00					
6,20						16,20					
6,40						16,40					
6,60						16,60					
6,80						16,80					
7,00						17,00					
7,20						17,20					
7,40						17,40					
7,60						17,60					
7,80						17,80					
8,00						18,00					
8,20						18,20					
8,40						18,40					
8,60						18,60					
8,80						18,80					
9,00						19,00					
9,20						19,20					
9,40						19,40					
9,60						19,60					
9,80						19,80					
10,00						20,00					



10 TON DUTCH CONE PENETRATION TEST

Project :
No. of CPT : SB. 1 Elevation : +1.00 meter dari muka jalan
Date : Ground Water Depth : -15.00 meter dari muka tanah

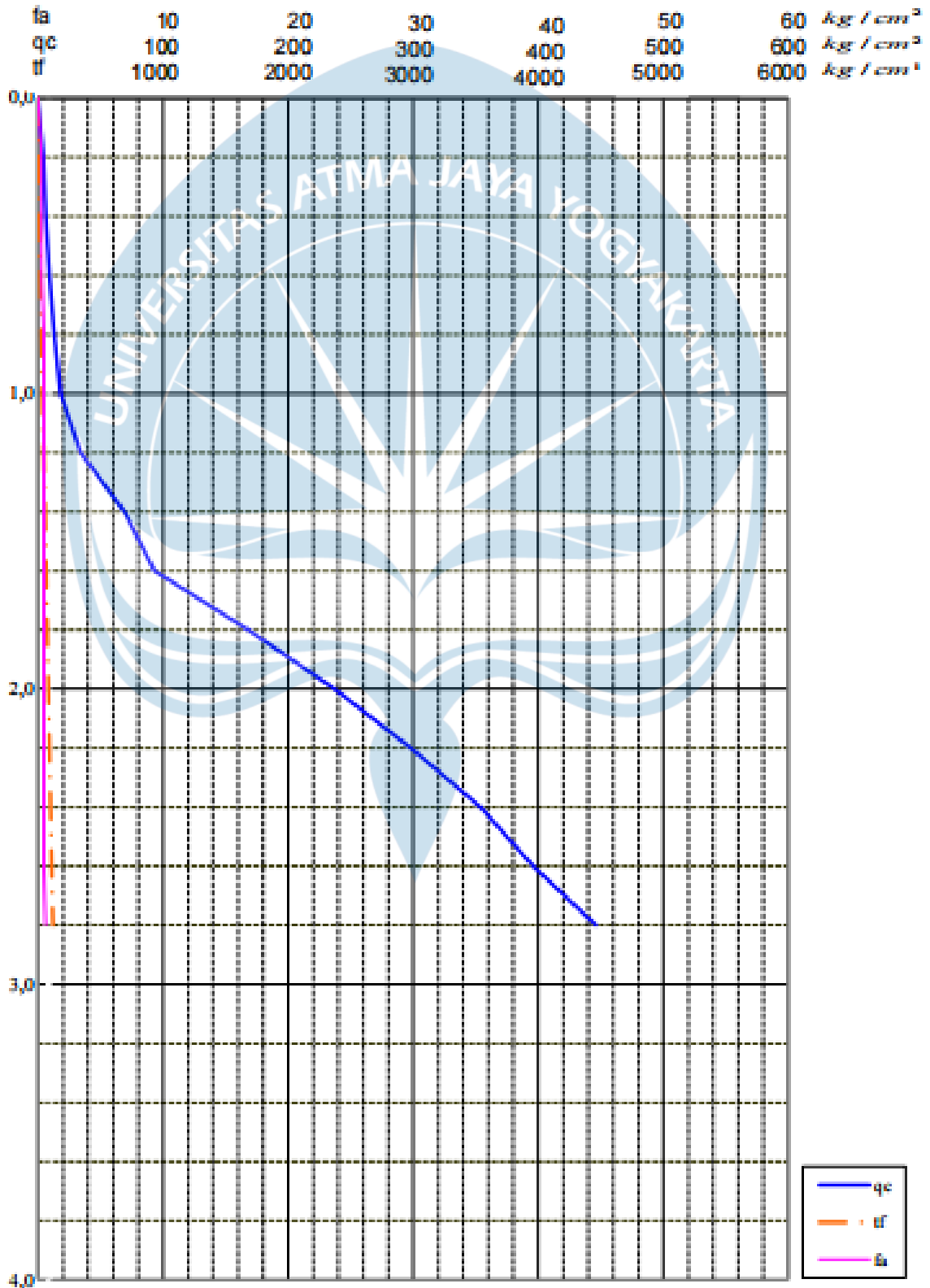

Lampiran A.4. Daya Dukung Tanah (Empiris)

Tabel Daya dukung tanah (empiris) kedalaman 10m CPT 1

Kedalaman	Qc	kedalaman	LF	kedalaman	LF
5,2	7	0	0	6,2	0,3
5,4	10	0,2	0,2	6,4	0,2
5,6	14	0,4	0,2	6,6	0,3
5,8	19	0,6	0,2	6,8	0,3
6	21	0,8	0,3	7	0,3
6,2	26	1	0,3	7,2	0,2
6,4	23	1,2	0,3	7,4	0,2
6,6	21	1,4	0,3	7,6	0,2
6,8	24	1,6	0,3	7,8	0,2
7	16	1,8	0,3	8	0,3
7,2	14	2	0,2	8,2	0,3
7,4	12	2,2	0,2	8,4	0,3
7,6	17	2,4	0,2	8,6	0,3
7,8	24	2,6	0,2	8,8	0,3
8	28	2,8	0,3	9	0,3
8,2	36	3	0,2	9,2	0,3
8,4	43	3,2	0,2	9,4	0,3
8,6	48	3,4	0,2	9,6	0,3
8,8	44	3,6	0,3	9,8	0,3
9	35	3,8	0,3	10	0,3
9,2	41	4	0,2	10,2	0,3
9,4	49	4,2	0,3	10,4	0,3
9,6	63	4,4	0,3	10,6	0,3
9,8	54	4,6	0,3	10,8	0,3
10	52	4,8	0,3	11	0,3
10,2	46	5	0,3	11,2	0,3
10,4	52	5,2	0,2	11,4	0,3
10,6	61	5,4	0,3	11,6	0,3
10,8	68	5,6	0,3	11,8	0,3
11	63	5,8	0,3	12	0,3
11,2	59	6	0,3		

Tabel Daya dukung tanah (empiris) kedalaman 10m CPT 2

Kedalaman	Qc	kedalaman	LF	kedalaman	LF
5,2	7	0	0	6,2	0,3
5,4	10	0,2	0,1	6,4	0,3
5,6	14	0,4	0,2	6,6	0,3
5,8	19	0,6	0,2	6,8	0,3
6	21	0,8	0,3	7	0,3
6,2	26	1	0,3	7,2	0,3
6,4	23	1,2	0,3	7,4	0,3
6,6	21	1,4	0,3	7,6	0,3
6,8	24	1,6	0,3	7,8	0,3
7	16	1,8	0,3	8	0,3
7,2	14	2	0,3	8,2	0,3
7,4	12	2,2	0,2	8,4	0,3
7,6	17	2,4	0,2	8,6	0,3
7,8	24	2,6	0,3	8,8	0,3
8	28	2,8	0,3	9	0,3
8,2	36	3	0,3	9,2	0,3
8,4	43	3,2	0,2	9,4	0,3
8,6	48	3,4	0,3	9,6	0,3
8,8	44	3,6	0,3	9,8	0,3
9	35	3,8	0,3	10	0,3
9,2	41	4	0,3	10,2	0,3
9,4	49	4,2	0,3	10,4	0,3
9,6	63	4,4	0,3	10,6	0,3
9,8	54	4,6	0,3	10,8	0,3
10	52	4,8	0,2	11	0,2
10,2	46	5	0,2	11,2	0,3
10,4	52	5,2	0,2	11,4	0,3
10,6	61	5,4	0,3	11,6	0,3
10,8	68	5,6	0,3	11,8	0,3
11	63	5,8	0,3	12	0,3
11,2	59	6	0,3		

Tabel Daya dukung tanah (empiris) kedalaman 10m CPT 3

Kedalaman	Qc	kedalaman	LF	kedalaman	LF
5,2	10	0	0	6,2	0,3
5,4	14	0,2	0,1	6,4	0,3
5,6	18	0,4	0,2	6,6	0,3
5,8	16	0,6	0,2	6,8	0,3
6	24	0,8	0,3	7	0,3
6,2	26	1	0,3	7,2	0,3
6,4	32	1,2	0,3	7,4	0,3
6,6	25	1,4	0,3	7,6	0,3
6,8	23	1,6	0,3	7,8	0,3
7	18	1,8	0,3	8	0,3
7,2	20	2	0,3	8,2	0,3
7,4	16	2,2	0,2	8,4	0,3
7,6	22	2,4	0,2	8,6	0,3
7,8	26	2,6	0,3	8,8	0,3
8	31	2,8	0,3	9	0,3
8,2	35	3	0,3	9,2	0,3
8,4	39	3,2	0,2	9,4	0,3
8,6	40	3,4	0,3	9,6	0,3
8,8	36	3,6	0,3	9,8	0,3
9	34	3,8	0,3	10	0,3
9,2	32	4	0,3	10,2	0,3
9,4	33	4,2	0,3	10,4	0,3
9,6	41	4,4	0,3	10,6	0,3
9,8	46	4,6	0,3	10,8	0,3
10	48	4,8	0,2	11	0,2
10,2	39	5	0,2	11,2	0,3
10,4	34	5,2	0,2	11,4	0,3
10,6	41	5,4	0,3	11,6	0,3
10,8	46	5,6	0,3	11,8	0,3
11	63	5,8	0,3	12	0,3
11,2	58	6	0,3		

Tabel Daya dukung tanah (empiris) kedalaman 14m CPT 1

kedalaman	qc	kedalaman	LF	kedalaman	LF
9,2	31	0	0	7,2	0,2
9,4	35	0,2	0,2	7,4	0,2
9,6	29	0,4	0,2	7,6	0,2
9,8	24	0,6	0,2	7,8	0,2
10	23	0,8	0,3	8	0,3
10,2	28	1	0,3	8,2	0,3
10,4	33	1,2	0,3	8,4	0,3
10,6	30	1,4	0,3	8,6	0,3
10,8	34	1,6	0,2	8,8	0,3
11	32	1,8	0,2	9	0,3
11,2	46	2	0,2	9,2	0,3
11,4	51	2,2	0,2	9,4	0,3
11,6	74	2,4	0,2	9,6	0,3
11,8	68	2,6	0,2	9,8	0,3
12	76	2,8	0,2	10	0,3
12,2	89	3	0,2	10,2	0,3
12,4	93	3,2	0,2	10,4	0,3
12,6	104	3,4	0,2	10,6	0,3
12,8	115	3,6	0,3	10,8	0,3
13	108	3,8	0,2	11	0,3
13,2	125	4	0,2	11,2	0,3
13,4	141	4,2	0,3	11,4	0,3
13,6	133	4,4	0,3	11,6	0,3
13,8	138	4,6	0,3	11,8	0,3
14	146	4,8	0,3	12	0,3
14,2	162	5	0,3	12,2	0,3
14,4	179	5,2	0,2	12,4	0,3
14,6	184	5,4	0,3	12,6	0,3
14,8	196	5,6	0,3	12,8	0,3
15	208	5,8	0,3	13	0,3
15,2	224	6	0,3	13,2	0,3
		6,2	0,3	13,4	0,2
		6,4	0,2	13,6	0,3
		6,6	0,3	13,8	0,3
		6,8	0,3	14	0,3
		7	0,3		

Tabel Daya dukung tanah (empiris) kedalaman 14m CPT 2

Kedalaman	Qc	kedalaman	LF	kedalaman	LF
9,2	41	0	0	7,2	0,3
9,4	49	0,2	0,1	7,4	0,3
9,6	63	0,4	0,2	7,6	0,3
9,8	54	0,6	0,2	7,8	0,3
10	52	0,8	0,3	8	0,3
10,2	46	1	0,3	8,2	0,3
10,4	52	1,2	0,3	8,4	0,3
10,6	61	1,4	0,3	8,6	0,3
10,8	68	1,6	0,3	8,8	0,3
11	63	1,8	0,3	9	0,3
11,2	59	2	0,3	9,2	0,3
11,4	54	2,2	0,2	9,4	0,3
11,6	61	2,4	0,2	9,6	0,3
11,8	68	2,6	0,3	9,8	0,3
12	89	2,8	0,3	10	0,3
12,2	102	3	0,3	10,2	0,3
12,4	116	3,2	0,2	10,4	0,3
12,6	108	3,4	0,3	10,6	0,3
12,8	101	3,6	0,3	10,8	0,3
13	92	3,8	0,3	11	0,2
13,2	105	4	0,3	11,2	0,3
13,4	119	4,2	0,3	11,4	0,3
13,6	136	4,4	0,3	11,6	0,3
13,8	145	4,6	0,3	11,8	0,3
14	138	4,8	0,2	12	0,3
14,2	143	5	0,2	12,2	0,3
14,4	156	5,2	0,2	12,4	0,3
14,6	163	5,4	0,3	12,6	0,3
14,8	179	5,6	0,3	12,8	0,3
15	191	5,8	0,3	13	0,3
15,2	225	6	0,3	13,2	0,3
		6,2	0,3	13,4	0,3
		6,4	0,3	13,6	0,3
		6,6	0,3	13,8	0,3
		6,8	0,3	14	0,3
		7	0,3		

Tabel Daya dukung tanah (empiris) kedalaman 14m CPT 3

Kedalaman	Qc	kedalaman	LF	kedalaman	LF
9,2	32	0	0	7,2	0,3
9,4	33	0,2	0,1	7,4	0,3
9,6	41	0,4	0,2	7,6	0,3
9,8	46	0,6	0,2	7,8	0,3
10	48	0,8	0,3	8	0,3
10,2	39	1	0,3	8,2	0,3
10,4	34	1,2	0,3	8,4	0,3
10,6	41	1,4	0,3	8,6	0,3
10,8	46	1,6	0,3	8,8	0,3
11	63	1,8	0,3	9	0,3
11,2	58	2	0,3	9,2	0,3
11,4	64	2,2	0,2	9,4	0,3
11,6	72	2,4	0,2	9,6	0,3
11,8	74	2,6	0,3	9,8	0,3
12	86	2,8	0,3	10	0,3
12,2	78	3	0,3	10,2	0,3
12,4	84	3,2	0,2	10,4	0,3
12,6	92	3,4	0,3	10,6	0,3
12,8	103	3,6	0,3	10,8	0,3
13	115	3,8	0,3	11	0,3
13,2	124	4	0,3	11,2	0,3
13,4	120	4,2	0,3	11,4	0,3
13,6	126	4,4	0,3	11,6	0,3
13,8	135	4,6	0,3	11,8	0,3
14	141	4,8	0,2	12	0,3
14,2	169	5	0,2	12,2	0,3
14,4	153	5,2	0,2	12,4	0,3
14,6	164	5,4	0,3	12,6	0,3
14,8	178	5,6	0,3	12,8	0,3
15	196	5,8	0,3	13	0,3
15,2	214	6	0,3	13,2	0,3
		6,2	0,3	13,4	0,3
		6,4	0,3	13,6	0,3
		6,6	0,3	13,8	0,3
		6,8	0,3	14	0,3
		7	0,3		

Tabel Daya dukung tanah (empiris) kedalaman 12m CPT 1

kedalaman	qc	kedalaman	LF	kedalaman	LF
7,2	8	0	0	6,2	0,3
7,4	6	0,2	0,2	6,4	0,2
7,6	5	0,4	0,2	6,6	0,3
7,8	3	0,6	0,2	6,8	0,3
8	9	0,8	0,3	7	0,3
8,2	11	1	0,3	7,2	0,2
8,4	13	1,2	0,3	7,4	0,2
8,6	17	1,4	0,3	7,6	0,2
8,8	22	1,6	0,2	7,8	0,2
9	26	1,8	0,2	8	0,3
9,2	31	2	0,2	8,2	0,3
9,4	35	2,2	0,2	8,4	0,3
9,6	29	2,4	0,2	8,6	0,3
9,8	24	2,6	0,2	8,8	0,3
10	23	2,8	0,2	9	0,3
10,2	28	3	0,2	9,2	0,3
10,4	33	3,2	0,2	9,4	0,3
10,6	30	3,4	0,2	9,6	0,3
10,8	34	3,6	0,3	9,8	0,3
11	32	3,8	0,2	10	0,3
11,2	46	4	0,2	10,2	0,3
11,4	51	4,2	0,3	10,4	0,3
11,6	74	4,4	0,3	10,6	0,3
11,8	68	4,6	0,3	10,8	0,3
12	76	4,8	0,3	11	0,3
12,2	89	5	0,3	11,2	0,3
12,4	93	5,2	0,2	11,4	0,3
12,6	104	5,4	0,3	11,6	0,3
12,8	115	5,6	0,3	11,8	0,3
13	108	5,8	0,3	12	0,3
13,2	125	6	0,3		

Tabel Daya dukung tanah (empiris) kedalaman 12m CPT 2

Kedalaman	Qc	kedalaman	LF	kedalaman	LF
7,2	14	0	0	6,2	0,3
7,4	12	0,2	0,1	6,4	0,3
7,6	17	0,4	0,2	6,6	0,3
7,8	24	0,6	0,2	6,8	0,3
8	28	0,8	0,3	7	0,3
8,2	36	1	0,3	7,2	0,3
8,4	43	1,2	0,3	7,4	0,3
8,6	48	1,4	0,3	7,6	0,3
8,8	44	1,6	0,3	7,8	0,3
9	35	1,8	0,3	8	0,3
9,2	41	2	0,2	8,2	0,3
9,4	49	2,2	0,2	8,4	0,3
9,6	63	2,4	0,3	8,6	0,3
9,8	54	2,6	0,3	8,8	0,3
10	52	2,8	0,3	9	0,3
10,2	46	3	0,2	9,2	0,3
10,4	52	3,2	0,3	9,4	0,3
10,6	61	3,4	0,3	9,6	0,3
10,8	68	3,6	0,3	9,8	0,3
11	63	3,8	0,3	10	0,3
11,2	59	4	0,3	10,2	0,3
11,4	54	4,2	0,3	10,4	0,3
11,6	61	4,4	0,3	10,6	0,3
11,8	68	4,6	0,2	10,8	0,2
12	89	4,8	0,2	11	0,3
12,2	102	5	0,2	11,2	0,3
12,4	116	5,2	0,3	11,4	0,3
12,6	108	5,4	0,3	11,6	0,3
12,8	101	5,6	0,3	11,8	0,3
13	92	5,8	0,3	12	0,3
13,2	105	6	0		

Tabel Daya dukung tanah (empiris) kedalaman 12m CPT 3

Kedalaman	Qc	kedalaman	LF	kedalaman	LF
7,2	20	0	0	6,2	0,3
7,4	16	0,2	0,2	6,4	0,3
7,6	22	0,4	0,2	6,6	0,3
7,8	26	0,6	0,2	6,8	0,3
8	31	0,8	0,3	7	0,3
8,2	35	1	0,3	7,2	0,3
8,4	39	1,2	0,3	7,4	0,3
8,6	40	1,4	0,3	7,6	0,3
8,8	36	1,6	0,3	7,8	0,3
9	34	1,8	0,3	8	0,3
9,2	32	2	0,2	8,2	0,3
9,4	33	2,2	0,2	8,4	0,3
9,6	41	2,4	0,2	8,6	0,3
9,8	46	2,6	0,2	8,8	0,3
10	48	2,8	0,3	9	0,3
10,2	39	3	0,2	9,2	0,3
10,4	34	3,2	0,2	9,4	0,3
10,6	41	3,4	0,2	9,6	0,3
10,8	46	3,6	0,3	9,8	0,3
11	63	3,8	0,3	10	0,3
11,2	58	4	0,2	10,2	0,3
11,4	64	4,2	0,3	10,4	0,3
11,6	72	4,4	0,3	10,6	0,3
11,8	74	4,6	0,3	10,8	0,3
12	86	4,8	0,3	11	0,3
12,2	78	5	0,2	11,2	0,3
12,4	84	5,2	0,3	11,4	0,3
12,6	92	5,4	0,3	11,6	0,3
12,8	103	5,6	0,3	11,8	0,3
13	115	5,8	0,2	12	0,3
13,2	124	6	0,3		

Lampiran A.5. *Work Breakdown Structure (WBS)*

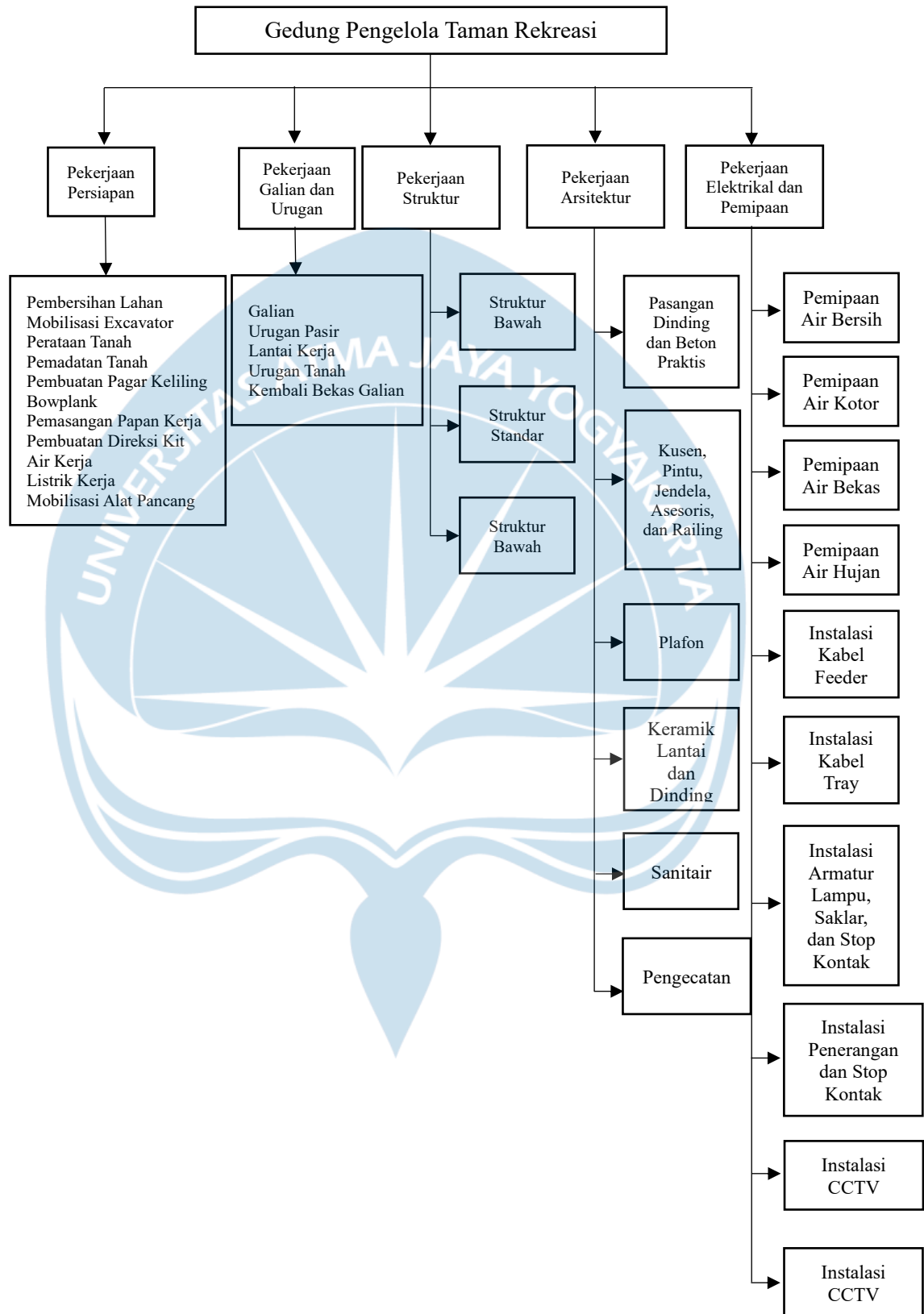

Lampiran A.6 Daftar Harga Bahan dan Upah Pekerja

Kode	Uraian	Harga	Satuan
		(Rp)	
M.01	Air	50	Liter
M.02	Kerikil (Maks 30 mm)	438	Kg
M.03	Besi Beton	12.000	Kg
M.04	Kawat Beton	26.100	kg
M.05	Pasir Urug	232.000	m3
M.06	Paku biasa 1/2"-1"	20.500	Kg
M.07	Multiplek 18 mm	337.000	Lembar
M.08	Kaso 5/7 cm	1.850.000	m3
M.09	Pasir Beton	148	Kg
M.10	Paku 5 cm dan 7 cm	21.000	Kg
M.11	Minyak Bekisting	5.000	Liter
M.12	Sirap Kayu	6.667	Buah
M.13	Mortar Siap Pakai	2.200	Kg
M.14	Bata Ringan 10 cm	8.520	Buah
M.15	Pasir Pasang	232.000	m3
M.16	Bata merah	950	Buah
M.17	Kayu Kelas 3	9.000.000	m3
M.18	Semen Portland	1.800	Kg
M.19	Kerikil 1m3	568.750	m3
M.20	Triplek 4 mm	74.750	lembar
M.21	Baja Profil L.60.60.6	16.600	Kg
M.22	Seng	50.000	Lembar
M.23	Paku 3"	28.000	kg
M.24	Baja Profil L.50.50.5	13.889	kg
M.25	baut 12 mm	381	Buah
M.26	Keramik 60x60 Polished	42.975	Buah
M.27	Semen Warna	2.750	kg
M.28	Plint 10x60	58.000	Buah
M.29	Kayu Dolken diameter 8-10 cm	40.000	batang
M.30	Residu	7.500	Liter
M.31	Papan Kayu 3/20	32.000	m3
M.32	Keramik 30x30	49.500	dus
M.33	gypsum board (12x240x9)	66.000	Lembar
M.34	Paku sekrup	19.090	kg
M.35	Rangka hollow 40.40.3	4.500	M
M.36	Alat sambung beton 40 cm		Buah
M.37	List Gypsum 8 cm	7.500	m'
M.38	Tepung Gypsum	3.750	kg

Kode	Uraian	Harga	Satuan
M.39	Closet Duduk TOTO CW638J	3.546.000	unit
M.40	Sepatu Pancang beton 40 cm	-	Buah
M.41	Tiang pancang dia.40 cm	552.500	m'
M.42	Alat sambung beton 60 cm	-	Buah
M.43	Sepatu Pancang beton 60 cm	-	Buah
M.44	Tiang pancang dia.60 cm	1.047.500	m'
M.45	Urinoir Lengkap	2.500.000	Unit
M.46	Plamuur	16.520	Kg
M.47	Cat Dasar Interior	45.900	Kg
M.48	Cat Penutup Interior	49.140	Kg
M.49	Cat Dasar Exterior	44.047	Kg
M.50	Cat Penutup Exterior	125.680	Kg
M.51	Partisi Urinoir TOTO A100	1.188.000	Buah
M.52	Kaca Cermin 5 mm ex Asahi	203.300	m2
M.53	Wastafel Vanitory Monaco exAmstad	1.130.800	Buah
M.54	Jet Washer American Standard FFTP404-WTFB0	240.000	Buah
M.55	Seal Tape	4.280	Buah
M.56	Floor Drain Stainless	157.000	Buah
M.57	Profil C150x65x20x3.2	15.346	Kg
M.58	Kayu Untuk Kusen Kelas 1	5.000.000	m3
M.59	Paku 10 cm	17.000	kg
M.60	Lem Kayu	42.800	kg
M.61	Kayu Untuk Daun Kelas 1	6.000.000	m3
M.62	Engsel Stainless Stell 4"	37.000	Buah
M.63	Engsel Stainless Stell 5"	69.500	Buah
M.64	Handle Tipe 2	128.000	Pasang
M.65	Handle Tipe 1	240.000	Pasang
M.66	Wood Filler	53.500	kg
M.67	Woodstain	69.550	Liter
M.68	Sending Sealer	69.550	Liter
M.69	Melamin Top Coat	82.000	Liter
M.70	Thinner	32.500	Liter
M.71	Amplas	4.900	Lembar
M.72	Alat Bantu (Alat semprot dll)	45.000	Ls
M.73	Kaca Bening 5 mm	175.000	M2
M.74	Sealent	55.886	kg
M.75	Reng G550	23.667	Kg
M.76	Angkur 16 mm (410 mm)	40.000	Buah
M.77	Profil C60x30x2.3	15.033	Kg
M.78	Keramik 60x60 Unpolished	34.000	Buah
M.79	Kawat Las	56.000	kg

Kode	Uraian	Harga	Satuan
		(Rp)	
M.80	Solar	6.800	Liter
M.81	Minyak Pelumas	120.000	Liter
M.82	Besi Hollow 40x40x1.2 mm	34.167	M
M.83	Cat Minyak Dulux V-Gloss	91.000	kg
M.84	Casement 8"	72.750	Pasang
M.85	Keramik Dinding 30x60	156.000	M2
M.86	Sekat PVC 0.5 mm	80.000	M2
M.87	Grendel Pintu PVC	2.000	Buah
M.88	Daun Pintu Tipe 1 (Kayu Kamper Samarinda)	5.426.400	Unit
M.89	Daun Pintu Tipe 2 (Kayu Kamper Samarinda)	3.876.000	Unit
M.90	Daun Pintu Tipe 3 (Kayu Kamper Samarinda)	2.907.000	Unit
M.91	Daun Pintu Tipe 4 (Kayu Kamper Samarinda)	1.938.000	Unit
M.92	Daun Pintu Tipe 5 (Kayu Kamper Samarinda)	1.550.400	Unit
M.93	Daun Jendela Tipe 1 (Kayu Kamper Samarinda)	472.340	Unit
M.94	Daun Jendela Tipe 2 (Kayu Kamper Samarinda)	319.200	Unit
M.95	Daun Jendela Tipe 3 (Kayu Kamper Samarinda)	269.040	Unit
M.96	Daun Boven (Kayu Kamper Samarinda)	209.380	Unit
M.97	Daun Jendela Tipe 3 (Kayu Kamper Samarinda)	1.070.346	Unit
M.98	Daun Boven (Kayu Kamper Samarinda)	1.066.280	Unit
M.99	Plavon PVC Indahfon t = 8 mm	150.500	M2
M.100	Screw	60	Buah
M.101	List PVC Shunda 3 cm	20.500	M'
M.102	Ready Mix K-300	1.370.000	M3
M.103	Stepnosing 10x60	16.000	Buah
M.104	Ready Mix K-175	1.200.000	M3
M.105	Assesoris (perkuatan & las dll)	18.000	
M.106	Pipa PVC Kelas dia 20 mm	9.075	M
M.107	Perlengkapan Pipa PVC Kelas AW dia 20 (12.5%)	1.134	
M.108	PVC Kelas AW dia. 110- 4"	92.575	M
M.109	Perlengkapan Pipa PVC Kleas AW dia 110 (12.5%)	11.572	
M.110	PVC Kelas AW dia. 75- 3"	55.875	M
M.111	Perlengkapan Pipa PVC Kleas AW dia 75 (12.5%)	6.984	
M.112	power Cables NYM 4 x 4 mm	17.700	M
M.113	Materil Bantu Kabel NYM 4x4(12.5%)	2.213	
M.114	NYA 3 x 2.5 mm2	8.340	M
M.115	PVC Conduit dia.20	6.500	M
M.116	Saklar 1 Gang	10.500	Buah
M.117	Saklar 2 Gang	35.000	Buah
M.118	Pipa PVC Kelas dia 25 mm	12.425	M
M.119	Perlengkapan Pipa PVC Kelas AW dia 25 (12.5%)	1.553	M
M.120	Roof Drain	370.000	Buah

Kode	Uraian	Harga	Satuan
		(Rp)	
M.121	Lampu TL LED 2 x 16 Watt	165.000	Buah
M.122	Lampu TL LED 14 Watt	113.000	Buah
M.123	Lampu Bohlam LED 10 Watt	45.500	Buah
M.124	Stop Kontak 250 watt	30.448	Buah
M.125	Cable Tray size 150x50x3000x1 (2 mm)	102.731	M
M.126	Material Bantu Cable Tray size 150x40x3000x1 (12.5%)	12.841	
M.127	Kabel Croaxial RG59	3.100	M
M.128	Material Bantu Kabel Croaxial RG59(12.5%)	388	
M.129	Kabel Lan	3.500	M
M.130	Material Bantu Kabel LAN (12.5)	438	
M.131	Perlengkapan Closed(6%)	212.760	
M.132	Perlengkapan Partisi Urinoir (30%)	356.400	
M.133	Perlengkapan Partisi Toilet (100%)	15.750	

Kode	Uraian	Harga
		(Rp)
L.01	Pekerja	95.000
L.02	Tukang Batu	150.000
L.03	Kepala Tukang Batu	165.000
L.04	Kepala Tukang Besi	165.000
L.05	Tukang Besi	150.000
L.06	Kepala Tukang Kayu	165.000
L.07	Tukang Kayu	150.000
L.08	Kepala Tukang Cat	165.000
L.09	Tukang Cat	150.000
L.10	Mandor Batu	175.000
L.11	Mandor Kayu	175.000
L.12	Mandor Besi	175.000
L.13	Mandor Cat	175.000
L.14	Tukang Listrik	150.000

Kode	Uraian	Harga
		(Rp)
L.15	Kepala Tukang Listrik	165.000
L.16	Mandor Listrik	175.000



Lampiran A.7. Analisis Harga Satuan Pekerjaan (AHSP)

AHSP

Membuat 1 m3 Beton Lantai Kerja (K100)						
No	Uraian	Kode	Satuan	Koefisien	Harga Satuan	Jumlah Harga
A	TENAGA KERJA					
	Pekerja	L.01	OH	1.000	Rp 95,000	Rp 95,000
	Kepala Tukang Batu	L.03	OH	0.025	Rp 165,000	Rp 4,125
	Tukang Batu	L.02	OH	0.250	Rp 150,000	Rp 37,500
	Mandor Batu	L.10	OH	0.100	Rp 175,000	Rp 17,500
	JUMLAH HARGA TENAGA KERJA					Rp 154,125
B	BAHAN					
	Semen Portland	M.18	kg	247	Rp 1,800	Rp 444,600
	Pasir Beton	M.09	kg	869	Rp 148	Rp 128,612
	Kerikil (Maks 30 mm)	M.02	kg	1000	Rp 438	Rp 437,519
	Air	M.01	ltr	215	Rp 50	Rp 10,750
	JUMLAH HARGA BAHAN					Rp 1,021,481
C	PERALATAN					
	Molen (0.35 m3)	E.03	Hari	0.238	Rp 250,000	Rp 59,500
	JUMLAH HARGA ALAT					Rp 59,500
D	Jumlah (A+B+C)					Rp 1,235,106
E	Overhead & Profit (15% × D)					Rp 185,266
F	Harga Satuan Pekerjaan (D+E)					Rp 1,420,372

(Sumber: peraturan menteri PUPR Republik Indonesia Nomor 1 tahun 2022)

Membuat 1 m3 Beton 14,5 MPa (K175) + pekerjaan Vibrator menggunakan Pompa Beton						
No	Uraian	Kode	Satuan	Koefisien	Harga Satuan	Jumlah Harga
A	TENAGA KERJA					
	Pekerja	L.01	OH	0.580	Rp 95,000	Rp 55,100
	Kepala Tukang Batu	L.03	OH	0.010	Rp 165,000	Rp 1,650
	Tukang Batu	L.02	OH	0.100	Rp 150,000	Rp 15,000
	Mandor Batu	L.10	OH	0.058	Rp 175,000	Rp 10,150
	JUMLAH HARGA TENAGA KERJA					Rp 81,900
B	BAHAN					
	Ready Mix K-175	M.104	M3	1	Rp 1,200,000	Rp 1,224,000
	JUMLAH HARGA BAHAN					Rp 1,224,000
C	PERALATAN					
	Pompa beton Ø 2,5", 75KW; 120 bar, T= 30 m'	E.04	Hari	0.04	Rp 3,500,000	Rp 140,000
	Concrete Vibrator φ 45 mm; 10 HP	E.05	Hari	0.08	Rp 650,000	Rp 52,000
	JUMLAH HARGA ALAT					Rp 140,000
D	Jumlah (A+B+C)					Rp 1,445,900
E	Overhead & Profit (15% × D)					Rp 216,885
F	Harga Satuan Pekerjaan (D+E)					Rp 1,662,785

(Sumber: peraturan menteri PUPR Republik Indonesia Nomor 1 tahun 2022)

Membuat 1 m3 Beton Mutu 26,4 MPa (K300) + pekerjaan Vibrator menggunakan Pompa Beton						
No	Uraian	Kode	Satuan	Koefisien	Harga Satuan	Jumlah Harga
A	TENAGA KERJA					
	Pekerja	L.01	OH	0.580	Rp 95,000	Rp 55,100
	Kepala Tukang Batu	L.03	OH	0.010	Rp 165,000	Rp 1,650
	Tukang Batu	L.02	OH	0.100	Rp 150,000	Rp 15,000

No	Uraian	Kode	Satuan	Koefisien	Harga Satuan	Jumlah Harga
	Mandor Batu	L.10	OH	0.058	Rp 175,000	Rp 10,150
JUMLAH HARGA TENAGA KERJA						Rp 81,900
B	BAHAN					
	Ready Mix K-300	M.102	M3	1	Rp 1,370,000	Rp 1,397,400
JUMLAH HARGA BAHAN						Rp 1,397,400
C	PERALATAN					
	Pompa beton Ø 2,5", 75KW; 120 bar, T= 30 m'	E.04	Hari	0.04	Rp 3,500,000	Rp 140,000
	Concrete Vibrator φ 45 mm; 10 HP	E.05	Hari	0.08	Rp 650,000	Rp 52,000
JUMLAH HARGA ALAT						Rp 192,000
D	Jumlah (A+B+C)					Rp 1,671,300
E	Overhead & Profit (15% × D)					Rp 250,695
F	Harga Satuan Pekerjaan (D+E)					Rp 1,921,995

(Sumber: peraturan menteri PUPR Republik Indonesia Nomor 1 tahun 2022)

Pekerjaan Pembesian (per 100 kg) untuk kolom, balok, ring balok, dan sloof						
No	Uraian	Kode	Satuan	Koefisien	Harga Satuan	Jumlah Harga
A	TENAGA KERJA					
	Pekerja	L.01	OH	0.160	Rp 95,000	Rp 15,200
	Tukang Besi	L.05	OH	0.080	Rp 150,000	Rp 12,000
	Kepala Tukang Besi	L.04	OH	0.008	Rp 165,000	Rp 1,320
	Mandor Besi	L.12	OH	0.016	Rp 175,000	Rp 2,800
JUMLAH HARGA TENAGA KERJA						Rp 31,320
B	BAHAN					
	Besi Beton	M.03	kg	105	Rp 12,000	Rp 1,260,000
	Kawat Beton	M.04	kg	3	Rp 26,100	Rp 73,080
JUMLAH HARGA BAHAN						Rp 1,333,080
C	PERALATAN					
	Mesin Potong Besi (Uk. 6-32 mm ; Berat 300 kg; Tegangan 2500-6600 watt)	E.01	Hari	0.04	Rp 75,000	Rp 3,000
	Bender Besi (Uk. 6-32 mm ; Berat 300 kg; Tegangan 2500-6600 watt)	E.02	Hari	0.04	Rp 75,000	Rp 3,000
JUMLAH HARGA ALAT						Rp 6,000
D	Jumlah (A+B+C)					Rp 1,370,400
E	Overhead & Profit (15% × D)					Rp 205,560
F	Harga Satuan Pekerjaan (D+E)					Rp 1,575,960

(Sumber: peraturan menteri PUPR Republik Indonesia Nomor 1 tahun 2022)

Pekerjaan Pembesian (per 100 kg) Pelat						
No	Uraian	Kode	Satuan	Koefisien	Harga Satuan	Jumlah Harga
A	TENAGA KERJA					
	Pekerja	L.01	OH	0.080	Rp 95,000	Rp 7,600
	Tukang Besi	L.05	OH	0.040	Rp 150,000	Rp 6,000
	Kepala Tukang Besi	L.04	OH	0.004	Rp 165,000	Rp 660
	Mandor Besi	L.12	OH	0.008	Rp 175,000	Rp 1,400
JUMLAH HARGA TENAGA KERJA						Rp 15,660
B	BAHAN					
	Besi Beton	M.03	kg	105	Rp 12,000	Rp 1,260,000

No	Uraian	Kode	Satuan	Koefisien	Harga Satuan	Jumlah Harga
	Kawat Beton	M.04	kg	2	Rp 26,100	Rp 39,150
JUMLAH HARGA BAHAN						Rp 1,299,150
C	PERALATAN					
	Mesin Potong Besi (Uk. 6-32 mm ; Berat 300 kg; Tegangan 2500-6600 watt)	E.01	Hari	0.02	Rp 75,000	Rp 1,500
	Bender Besi (Uk. 6-32 mm ; Berat 300 kg; Tegangan 2500-6600 watt)	E.02	Hari	0.02	Rp 75,000	Rp 1,500
JUMLAH HARGA ALAT						Rp 3,000
D	Jumlah (A+B+C)					Rp 1,317,810
E	Overhead & Profit (15% × D)					Rp 197,672
F	Harga Satuan Pekerjaan (D+E)					Rp 1,515,482

(Sumber: peraturan menteri PUPR Republik Indonesia Nomor 1 tahun 2022)

Pekerjaan Bekisting Lantai Beton multiplek 18 mm (1m2)						
No	Uraian	Kode	Satuan	Koefisien	Harga Satuan	Jumlah Harga
A	TENAGA KERJA					
	Pekerja	L.01	OH	0.500	Rp 95,000	Rp 47,500
	Tukang Kayu	L.07	OH	0.250	Rp 150,000	Rp 37,500
	Kepala Tukang Kayu	L.06	OH	0.025	Rp 165,000	Rp 4,125
	Mandor Kayu	L.11	OH	0.050	Rp 175,000	Rp 8,750
JUMLAH HARGA TENAGA KERJA						Rp 97,875
B	BAHAN					
	Multiplek 18 mm	M.07	Lembar	0.1280	Rp 337,000	Rp 43,136
	Kaso 5/7 cm	M.08	m3	0.0250	Rp 1,850,000	Rp 46,250
	Paku 5 cm dan 7 cm	M.10	kg	0.4700	Rp 21,000	Rp 9,870
	Minyak Bekisting	M.11	Liter	0.2000	Rp 5,000	Rp 1,000
JUMLAH HARGA BAHAN						Rp 100,256
C	PERALATAN					
JUMLAH HARGA ALAT						
D	Jumlah (A+B+C)					Rp 198,131

(Sumber: peraturan menteri PUPR Republik Indonesia Nomor 1 tahun 2022)

Pekerjaan Bekisting Balok Beton multiplek 18 mm (1m2)						
No	Uraian	Kode	Satuan	Koefisien	Harga Satuan	Jumlah Harga
A	TENAGA KERJA					
	Pekerja	L.01	OH	0.360	Rp 95,000	Rp 34,200
	Tukang Kayu	L.07	OH	0.360	Rp 150,000	Rp 54,000
	Kepala Tukang Kayu	L.06	OH	0.036	Rp 165,000	Rp 5,940
	Mandor Kayu	L.11	OH	0.036	Rp 175,000	Rp 6,300
JUMLAH HARGA TENAGA KERJA						Rp 100,440
B	BAHAN					
	Multiplek 18 mm	M.07	Lembar	0.1280	Rp 337,000	Rp 43,136
	Kaso 5/7 cm	M.08	m3	0.0110	Rp 1,850,000	Rp 20,350
	Paku 5 cm dan 7 cm	M.10	kg	0.2500	Rp 21,000	Rp 5,250
	Minyak Bekisting	M.11	Liter	0.2000	Rp 5,000	Rp 1,000
JUMLAH HARGA BAHAN						Rp 69,736
C	PERALATAN					
JUMLAH HARGA ALAT						
D	Jumlah (A+B+C)					Rp 170,176

No	Uraian	Kode	Satuan	Koefisien	Harga Satuan	Jumlah Harga
E	Overhead & Profit (15% × D)					Rp 25,526
F	Harga Satuan Pekerjaan (D+E)					Rp 195,702

(Sumber: peraturan menteri PUPR Republik Indonesia Nomor 1 tahun 2022)

1 m2 Bekisting kolom beton biasa dengan papan 3/20 cm						
No	Uraian	Kode	Satuan	Koefisien	Harga Satuan	Jumlah Harga
A	TENAGA KERJA					
	Pekerja	L.01	OH	0.340	Rp 95,000	Rp 32,300
	Tukang Kayu	L.07	OH	0.170	Rp 150,000	Rp 25,500
	Kepala Tukang Kayu	L.06	OH	0.017	Rp 165,000	Rp 2,805
	Mandor Kayu	L.11	OH	0.034	Rp 175,000	Rp 5,950
	JUMLAH HARGA TENAGA KERJA					Rp 66,555
B	BAHAN					
	Papan Kayu 3/20	M.31	Lembar	0.0140	Rp 32,000	Rp 448
	Kaso 5/7 cm	M.08	m3	0.0060	Rp 1,850,000	Rp 11,100
	Paku 5 cm dan 7 cm	M.10	kg	0.3000	Rp 21,000	Rp 6,300
	Minyak Bekisting	M.11	Liter	0.2000	Rp 5,000	Rp 1,000
	JUMLAH HARGA BAHAN					Rp 18,848
C	PERALATAN					
	JUMLAH HARGA ALAT					
D	Jumlah (A+B+C)					Rp 85,403

(Sumber: peraturan menteri PUPR Republik Indonesia Nomor 1 tahun 2022)

Pekerjaan Bekisting Fondasi dan Sloof Beton multiplek 18 mm (1m2)						
No	Uraian	Kode	Satuan	Koefisien	Harga Satuan	Jumlah Harga
A	TENAGA KERJA					
	Pekerja	L.01	OH	0.200	Rp 95,000	Rp 19,000
	Tukang Kayu	L.07	OH	0.100	Rp 150,000	Rp 15,000
	Kepala Tukang Kayu	L.06	OH	0.010	Rp 165,000	Rp 1,650
	Mandor Kayu	L.11	OH	0.020	Rp 175,000	Rp 3,500
	JUMLAH HARGA TENAGA KERJA					Rp 39,150
B	BAHAN					
	Multiplek 18 mm	M.07	Lembar	0.1280	Rp 337,000	Rp 43,136
	Kaso 5/7 cm	M.08	m3	0.0090	Rp 1,850,000	Rp 16,650
	Paku 5 cm dan 7 cm	M.10	kg	0.2500	Rp 21,000	Rp 5,250
	Minyak Bekisting	M.11	Liter	0.2000	Rp 5,000	Rp 1,000
	JUMLAH HARGA BAHAN					Rp 66,036
C	PERALATAN					
	JUMLAH HARGA ALAT					
D	Jumlah (A+B+C)					Rp 105,186
E	Overhead & Profit (15% × D)					Rp 15,778
F	Harga Satuan Pekerjaan (D+E)					Rp 120,964

(Sumber: peraturan menteri PUPR Republik Indonesia Nomor 1 tahun 2022)

Tebas tebang 1 m2 tanaman/tumbuhan Ø >5 s.d. 15 cm						
No	Uraian	Kode	Satuan	Koefisien	Harga Satuan	Jumlah Harga
A	TENAGA KERJA					
	Pekerja	L.01	OH	0.050	Rp 95,000	Rp 4,750
	Mandor Batu	L.10	OH	0.005	Rp 175,000	Rp 875
	JUMLAH HARGA TENAGA KERJA					Rp 5,625
B	BAHAN					
	JUMLAH HARGA BAHAN					
C	PERALATAN					
	JUMLAH HARGA ALAT					
D	Jumlah (A+B+C)					Rp 5,625
E	Overhead & Profit (15% × D)					Rp 844
F	Harga Satuan Pekerjaan (D+E)					Rp 6,469

(Sumber: peraturan menteri PUPR Republik Indonesia Nomor 1 tahun 2022)

Pekerjaan Galian Tanah Manual (1m3)						
No	Uraian	Kode	Satuan	Koefisien	Harga Satuan	Jumlah Harga
A	TENAGA KERJA					
	Pekerja	L.01	OH	0.563	Rp 95,000	Rp 53,485
	Mandor Batu	L.10	OH	0.056	Rp 175,000	Rp 9,853
	JUMLAH HARGA TENAGA KERJA					Rp 63,338
B	BAHAN					
	JUMLAH HARGA BAHAN					
C	PERALATAN					
	JUMLAH HARGA ALAT					
D	Jumlah (A+B+C)					Rp 63,338

(Sumber: peraturan menteri PUPR Republik Indonesia Nomor 1 tahun 2022)

Pekerjaan Galian Tanah Menggunakan Excavator (1m3)							
No	Uraian	Kode	Satuan	Koefisien	Harga Satuan	Jumlah Harga	
A	TENAGA KERJA						
	JUMLAH HARGA TENAGA KERJA						Rp -
B	BAHAN						
	JUMLAH HARGA BAHAN						
C	PERALATAN						
	Excavator PC.75 Cap 0.3 m3		Hari	0.0069305	Rp 1,610,000	Rp 11,158	
	Dump Truck		Hari	0.00434864	Rp 1,250,000	Rp 5,436	
	JUMLAH HARGA ALAT					Rp 16,594	
D	Jumlah (A+B+C)					Rp 16,594	

(Sumber: peraturan menteri PUPR Republik Indonesia Nomor 1 tahun 2022)

Pemadatan Tanah 1 m3						
No	Uraian	Kode	Satuan	Koefisien	Harga Satuan	Jumlah Harga
A	TENAGA KERJA					
	Pekerja	L.01	OH	0.045	Rp 95,000	Rp 4,237
	Mandor Batu	L.10	OH	0.005	Rp 175,000	Rp 788
	JUMLAH HARGA TENAGA KERJA					Rp 5,025
	JUMLAH HARGA BAHAN					
C	PERALATAN					
	Mesin Stamper 250 kg	E.10	Hari	0.0223	Rp -	Rp -
	JUMLAH HARGA ALAT					Rp -
D	Jumlah (A+B+C)					Rp 5,025
E	Overhead & Profit (15% × D)					Rp 754

1 m3 Timbunan atau urugan kembali tanah biasa/liat berpasir						
No	Uraian	Kode	Satuan	Koefisien	Harga Satuan	Jumlah Harga
A	TENAGA KERJA					
	Pekerja	L.01	OH	0.1000	Rp 95,000	Rp 9,500
	Mandor Batu	L.10	OH	0.0100	Rp 175,000	Rp 1,750
	JUMLAH HARGA TENAGA KERJA					Rp 11,250
B	BAHAN					
	JUMLAH HARGA BAHAN					
C	PERALATAN					
	JUMLAH HARGA ALAT					
D	Jumlah (A+B+C)					Rp 11,250
E	Overhead & Profit (15% × D)					Rp 1,688

Pekerjaan Urugan Tanah Kembali Manual (1m3)						
No	Uraian	Kode	Satuan	Koefisien	Harga Satuan	Jumlah Harga
A	TENAGA KERJA					
	Pekerja	L.01	OH	0.500	Rp 95,000	Rp 47,500
	Mandor Batu	L.10	OH	0.050	Rp 175,000	Rp 8,750
	JUMLAH HARGA TENAGA KERJA					Rp 56,250
B	BAHAN					
	JUMLAH HARGA BAHAN					
C	PERALATAN					
	JUMLAH HARGA ALAT					
D	Jumlah (A+B+C)					Rp 56,250
E	Overhead & Profit (15% × D)					Rp 8,438
F	Harga Satuan Pekerjaan (D+E)					Rp 64,688

Pekerjaan Urugan Pasir (1m3)						
No	Uraian	Kode	Satuan	Koefisien	Harga Satuan	Jumlah Harga
A	TENAGA KERJA					
	Pekerja	L.01	OH	0.300	Rp 95,000	Rp 28,500
	Mandor Batu	L.10	OH	0.010	Rp 175,000	Rp 1,750
	JUMLAH HARGA TENAGA KERJA					Rp 30,250
B	BAHAN					
	Pasir Urug	M.05	M3	1.2	Rp 232,000	Rp 278,400
	JUMLAH HARGA BAHAN					Rp 278,400
C	PERALATAN					
	JUMLAH HARGA ALAT					
D	Jumlah (A+B+C)					Rp 308,650
E	Overhead & Profit (15% × D)					Rp 46,298
F	Harga Satuan Pekerjaan (D+E)					Rp 354,948

Pembuatan direksi keet dan gudang						
No	Uraian	Kode	Satuan	Koefisien	Harga Satuan	Jumlah Harga
A	TENAGA KERJA					
	Pekerja	L.01	OH	1.200	Rp 95,000	Rp 114,000
	Tukang Batu	L.02	OH	0.400	Rp 150,000	Rp 60,000
	Kepala Tukang Batu	L.03	OH	0.040	Rp 165,000	Rp 6,600
	Mandor Batu	L.10	OH	0.120	Rp 175,000	Rp 21,000
	JUMLAH HARGA TENAGA KERJA					Rp 201,600
B	BAHAN					
	Kaso 5/7 cm	M.08	m3	0.0300	Rp 1,850,000	Rp 55,500
	Triplek 4 mm	M.20	lembar	0.2000	Rp 74,750	Rp 14,950
	Seng	M.22	lembar	1.2400	Rp 50,000	Rp 62,000
	Paku 3"	M.23	kg	0.7500	Rp 28,000	Rp 21,000
	JUMLAH HARGA BAHAN					Rp 153,450
C	PERALATAN					
	JUMLAH HARGA ALAT					
D	Jumlah (A+B+C)					Rp 355,050
E	Overhead & Profit (15% × D)					Rp 53,258
F	Harga Satuan Pekerjaan (D+E)					Rp 408,308

Perakitan baja Profil L.50.50.5 (per kg)						
No	Uraian	Kode	Satuan	Koefisien	Harga Satuan	Jumlah Harga
A	TENAGA KERJA					
	Pekerja	L.01	OH	0.0600	Rp 95,000	Rp 5,700
	Tukang Besi	L.05	OH	0.0600	Rp 150,000	Rp 9,000
	Kepala Tukang Besi	L.04	OH	0.0060	Rp 165,000	Rp 990
	Mandor Besi	L.12	OH	0.0030	Rp 175,000	Rp 525
	JUMLAH HARGA TENAGA KERJA					Rp 16,215
B	BAHAN					
	Baja Profil L.50.50.5	M.24	kg	1.1500	Rp 13,889	Rp 15,972
	baut 12 mm	M.25	buah	0.3585	Rp 381	Rp 137
	JUMLAH HARGA BAHAN					Rp 16,109
C	PERALATAN					
	JUMLAH HARGA ALAT					
D	Jumlah (A+B+C)					Rp 32,324
E	Overhead & Profit (15% × D)					Rp 4,849
F	Harga Satuan Pekerjaan (D+E)					Rp 37,172

Perakitan dan perakitan baja Profil L.60.60.5 (per kg)						
No	Uraian	Kode	Satuan	Koefisien	Harga Satuan	Jumlah Harga
A	TENAGA KERJA					
	Pekerja	L.01	OH	0.0600	Rp 95,000	Rp 5,700
	Tukang Besi	L.05	OH	0.0600	Rp 150,000	Rp 9,000
	Kepala Tukang Besi	L.04	OH	0.0060	Rp 165,000	Rp 990
	Mandor Besi	L.12	OH	0.0030	Rp 175,000	Rp 525
	JUMLAH HARGA TENAGA KERJA					Rp 16,215

No	Uraian	Kode	Satuan	Koefisien	Harga Satuan	Jumlah Harga
B	BAHAN					
	Baja Profil L.60.60.6	M.21	Kg	1.1500	Rp 16,600	Rp 19,090
	baut 12 mm	M.25	buah	0.3269	Rp 381	Rp 125
	JUMLAH HARGA BAHAN					Rp 19,215
C	PERALATAN					
	JUMLAH HARGA ALAT					
D	Jumlah (A+B+C)					Rp 35,430
E	Overhead & Profit (15% × D)					Rp 5,314
F	Harga Satuan Pekerjaan (D+E)					Rp 40,744

Pembuatan Pagar Sementara dari kayu Tinggi 2m (m')						
No	Uraian	Kode	Satuan	Koefisien	Harga Satuan	Jumlah Harga
A	TENAGA KERJA					
	Pekerja	L.01	OH	0.400	Rp 95,000	Rp 38,000
	Tukang Kayu	L.07	OH	0.200	Rp 150,000	Rp 30,000
	Kepala Tukang Kayu	L.06	OH	0.020	Rp 165,000	Rp 3,000
	Mandor Kayu	L.11	OH	0.020	Rp 175,000	Rp 3,500
	JUMLAH HARGA TENAGA KERJA					Rp 74,500
B	BAHAN					
	Kayu Dolken diameter 8-10 cm	M.29	Batang	1.2500	Rp 40,000	Rp 50,000
	Semen Portland	M.18	Kg	5.0000	Rp 1,800	Rp 9,000
	Pasir Pasang	M.15	m3	0.0050	Rp 232,000	Rp 1,160
	Kerikil 1m3	M.19	m3	0.0090	Rp 568,750	Rp 5,119
	Kaso 5/7 cm	M.08	m3	0.0720	Rp 1,850,000	Rp 133,200
	Paku 5 cm dan 7 cm	M.10	Kg	0.0600	Rp 21,000	Rp 1,260
	Residu	M.30	Liter	0.4000	Rp 7,500	Rp 3,000
	JUMLAH HARGA BAHAN					Rp 202,739
C	PERALATAN					
	JUMLAH HARGA ALAT					
D	Jumlah (A+B+C)					Rp 277,239
E	Overhead & Profit (15% × D)					Rp 41,586
F	Harga Satuan Pekerjaan (D+E)					Rp 318,825

(Sumber: peraturan menteri PUPR Republik Indonesia Nomor 1 tahun 2022)

Pengukuran dan pengerjaan bouwplank (m')						
No	Uraian	Kode	Satuan	Koefisien	Harga Satuan	Jumlah Harga
A	TENAGA KERJA					
	Pekerja	L.01	OH	0.100	Rp 95,000	Rp 9,500
	Tukang Kayu	L.07	OH	0.100	Rp 150,000	Rp 15,000
	Kepala Tukang Kayu	L.06	OH	0.010	Rp 165,000	Rp 1,500
	Mandor Kayu	L.11	OH	0.005	Rp 175,000	Rp 875
	JUMLAH HARGA TENAGA KERJA					Rp 26,875
B	BAHAN					
	Kaso 5/7 cm	M.08	m3	0.0120	Rp 1,850,000	Rp 22,200
	Paku 3"	M.23	Kg	0.0200	Rp 28,000	Rp 560
	Papan Kayu 3/20	M.31	M3	0.0070	Rp 32,000	Rp 224
	JUMLAH HARGA BAHAN					Rp 22,984
C	PERALATAN					
	JUMLAH HARGA ALAT					
D	Jumlah (A+B+C)					Rp 49,859
E	Overhead & Profit (15% × D)					Rp 7,479
F	Harga Satuan Pekerjaan (D+E)					Rp 57,338

(Sumber: peraturan menteri PUPR Republik Indonesia Nomor 1 tahun 2022)

Pekerjaan pemancangan spun pile diameter 60 cm per buah						
No	Uraian	Kode	Satuan	Koefisien	Harga Satuan	Jumlah Harga
A	TENAGA KERJA					
	Pekerja	L.01	OH	4.002	Rp 95,000	Rp 380,190
	Tukang Batu	L.02	OH	0.800	Rp 150,000	Rp 120,060
	Mandor Batu	L.10	OH	0.401	Rp 175,000	Rp 70,140
	JUMLAH HARGA TENAGA KERJA					Rp 570,390
B	BAHAN					
	Sepatu Pancang beton 60 cm	M.43	buah	1.0000	Rp -	Rp -
	Tiang pancang dia.60 cm	M.44	m'	12.0000	Rp 1,047,500	Rp 12,570,000
	JUMLAH HARGA BAHAN					Rp 12,570,000
C	PERALATAN					
	Alat Pancang HSPD 420 (Tekanan maksimum 420 ton; Spun Pile Uk. 300 - 600 mm)	E.06	Hari	0.11535	Rp 700,000	Rp 80,745
	JUMLAH HARGA ALAT					Rp 80,745
D	Jumlah (A+B+C)					Rp 13,221,135
E	Overhead & Profit (15% × D)					Rp 1,983,170
F	Harga Satuan Pekerjaan (D+E)					Rp 15,204,305

Perakitan Reng						
No	Uraian	Kode	Satuan	Koefisien	Harga Satuan	Jumlah Harga
A	TENAGA KERJA					
	Pekerja	L.01	OH	0.0600	Rp 95,000	Rp 5,700
	Tukang Besi	L.05	OH	0.0600	Rp 150,000	Rp 9,000
	Kepala Tukang Besi	L.04	OH	0.0060	Rp 165,000	Rp 990
	Mandor Besi	L.12	OH	0.0030	Rp 175,000	Rp 525
	JUMLAH HARGA TENAGA KERJA					Rp 16,215
B	BAHAN					
	Reng G550	M.75	Kg	1.1500	Rp 23,667	Rp 27,217
	JUMLAH HARGA BAHAN					Rp 27,217
C	PERALATAN					
	JUMLAH HARGA ALAT					
D	Jumlah (A+B+C)					Rp 43,432
E	Overhead & Profit (15% × D)					Rp 6,515
F	Harga Satuan Pekerjaan (D+E)					Rp 49,946

Perakitan Usuk (per kilo)						
No	Uraian	Kode	Satuan	Koefisien	Harga Satuan	Jumlah Harga
A	TENAGA KERJA					
	Pekerja	L.01	OH	0.0600	Rp 95,000	Rp 5,700
	Tukang Besi	L.05	OH	0.0600	Rp 150,000	Rp 9,000
	Kepala Tukang Besi	L.04	OH	0.0060	Rp 165,000	Rp 990
	Mandor Besi	L.12	OH	0.0030	Rp 175,000	Rp 525
	JUMLAH HARGA TENAGA KERJA					Rp 16,215
B	BAHAN					
	Profil C60x30x2.3	M.77	Kg	1.1500	Rp 15,033	Rp 17,288
	JUMLAH HARGA BAHAN					Rp 17,288
C	PERALATAN					
	JUMLAH HARGA ALAT					
D	Jumlah (A+B+C)					Rp 33,503
E	Overhead & Profit (15% × D)					Rp 5,026

Perakitan Ikatan Angin						
No	Uraian	Kode	Satuan	Koefisien	Harga Satuan	Jumlah Harga
A	TENAGA KERJA					
	Pekerja	L.01	OH	0.0600	Rp 95,000	Rp 5,700
	Tukang Besi	L.05	OH	0.0600	Rp 150,000	Rp 9,000
	Kepala Tukang Besi	L.04	OH	0.0060	Rp 165,000	Rp 990
	Mandor Besi	L.12	OH	0.0030	Rp 175,000	Rp 525
	JUMLAH HARGA TENAGA KERJA					Rp 16,215
B	BAHAN					
	Besi Beton	M.03	Kg	1.1500	Rp 12,000	Rp 13,800
	JUMLAH HARGA BAHAN					Rp 13,800
C	PERALATAN					
	JUMLAH HARGA ALAT					
D	Jumlah (A+B+C)					Rp 30,015
E	Overhead & Profit (15% × D)					Rp 4,502
F	Harga Satuan Pekerjaan (D+E)					Rp 34,517

Perakitan Sagrod						
No	Uraian	Kode	Satuan	Koefisien	Harga Satuan	Jumlah Harga
A	TENAGA KERJA					
	Pekerja	L.01	OH	0.0600	Rp 95,000	Rp 5,700
	Tukang Besi	L.05	OH	0.0600	Rp 150,000	Rp 9,000
	Kepala Tukang Besi	L.04	OH	0.0060	Rp 165,000	Rp 990
	Mandor Besi	L.12	OH	0.0030	Rp 175,000	Rp 525
	JUMLAH HARGA TENAGA KERJA					Rp 16,215
B	BAHAN					
	Besi Beton	M.03	Kg	1.1500	Rp 12,000	Rp 13,800
	JUMLAH HARGA BAHAN					Rp 13,800
C	PERALATAN					
	JUMLAH HARGA ALAT					
D	Jumlah (A+B+C)					Rp 30,015
E	Overhead & Profit (15% × D)					Rp 4,502
F	Harga Satuan Pekerjaan (D+E)					Rp 34,517

Trasraam tebal 2,0 cm, dengan mortar campuran fc'= 25 MPa (Setara 1 PC : 1 PP)						
No	Uraian	Kode	Satuan	Koefisien	Harga Satuan	Jumlah Harga
A	TENAGA KERJA					
	Pekerja	L.01	OH	0.160	Rp 95,000	Rp 15,200
	Tukang Batu	L.02	OH	0.160	Rp 150,000	Rp 24,000
	Kepala Tukang Batu	L.03	OH	0.016	Rp 165,000	Rp 2,640
	Mandor Batu	L.10	OH	0.016	Rp 175,000	Rp 2,800
	JUMLAH HARGA TENAGA KERJA					Rp 44,640
B	BAHAN					
	Semen Portland	M.18	Kg	20.6720	Rp 1,800	Rp 37,210
	Pasir pasang	M.15	M3	0.0214	Rp 232,000	Rp 4,965
	JUMLAH HARGA BAHAN					Rp 42,174
C	PERALATAN					
	JUMLAH HARGA ALAT					
D	Jumlah (A+B+C)					Rp 86,814
E	Overhead & Profit (15% × D)					Rp 13,022
F	Harga Satuan Pekerjaan (D+E)					Rp 99,837

(Sumber: peraturan menteri PUPR Republik Indonesia Nomor 1 tahun 2022)

Pemasangan 1m² Dinding Bata Merah (5x11x22) cm tebal 1 Batu Campuran 1SP : 5PP						
No	Uraian	Kode	Satuan	Koefisien	Harga Satuan	Jumlah Harga
A	TENAGA KERJA					
	Pekerja	L.01	OH	0.600	Rp 95,000	Rp 57,000
	Tukang Batu	L.02	OH	0.200	Rp 150,000	Rp 30,000
	Kepala Tukang Batu	L.03	OH	0.020	Rp 165,000	Rp 3,300
	Mandor Batu	L.10	OH	0.020	Rp 175,000	Rp 3,500
	JUMLAH HARGA TENAGA KERJA					Rp 93,800
B	BAHAN					
	Bata merah	M.16	Buah	140.0000	Rp 950	Rp 133,000
	Semen Portland	M.18	Kg	22.2000	Rp 1,800	Rp 39,960
	Pasir Pasang	M.15	m ³	0.1020	Rp 232,000	Rp 23,664
	JUMLAH HARGA BAHAN					Rp 196,624
C	PERALATAN					
	JUMLAH HARGA ALAT					
D	Jumlah (A+B+C)					Rp 290,424
E	Overhead & Profit (15% × D)					Rp 43,564
F	Harga Satuan Pekerjaan (D+E)					Rp 333,988

(Sumber: peraturan menteri PUPR Republik Indonesia Nomor 1 tahun 2022)

Pekerjaan Pemasangan Bata ringan 1m² 1SP:5PP						
No	Uraian	Kode	Satuan	Koefisien	Harga Satuan	Jumlah Harga
A	TENAGA KERJA					
	Pekerja	L.01	OH	0.600	Rp 95,000	Rp 57,000
	Tukang Batu	L.02	OH	0.130	Rp 150,000	Rp 19,500
	Kepala Tukang Batu	L.03	OH	0.013	Rp 165,000	Rp 2,145
	Mandor Batu	L.10	OH	0.003	Rp 175,000	Rp 525
	JUMLAH HARGA TENAGA KERJA					Rp 79,170
B	BAHAN					
	Bata Ringan 10 cm	M.14	Buah	8.4000	Rp 8,520	Rp 71,568
	Mortar Siap Pakai	M.13	Kg	0.0630	Rp 2,200	Rp 139
	JUMLAH HARGA BAHAN					Rp 71,707
C	PERALATAN					
	JUMLAH HARGA ALAT					
D	Jumlah (A+B+C)					Rp 150,877
E	Overhead & Profit (15% × D)					Rp 22,631
F	Harga Satuan Pekerjaan (D+E)					Rp 173,508

(Sumber: peraturan menteri PUPR Republik Indonesia Nomor 1 tahun 2022)

Plesteran tebal 2,5 cm, dengan mortar tipe S, f_c' = 12,5 MPa (Setara 1 PC : 3 PP)						
No	Uraian	Kode	Satuan	Koefisien	Harga Satuan	Jumlah Harga
A	TENAGA KERJA					
	Pekerja	L.01	OH	0.190	Rp 95,000	Rp 18,050
	Tukang Batu	L.02	OH	0.190	Rp 150,000	Rp 28,500
	Kepala Tukang Batu	L.03	OH	0.019	Rp 165,000	Rp 3,135
	Mandor Batu	L.10	OH	0.019	Rp 175,000	Rp 3,325
	JUMLAH HARGA TENAGA KERJA					Rp 53,010
B	BAHAN					
	Semen Portland	M.18	Kg	12.9600	Rp 1,800	Rp 23,328
	Pasir pasang	M.15	M ³	0.0385	Rp 232,000	Rp 8,932
	JUMLAH HARGA BAHAN					Rp 32,260
C	PERALATAN					

No	Uraian	Kode	Satuan	Koefisien	Harga Satuan	Jumlah Harga
JUMLAH HARGA ALAT						
D	Jumlah (A+B+C)					Rp 85,270
E	Overhead & Profit (15% × D)					Rp 12,791
F	Harga Satuan Pekerjaan (D+E)					Rp 98,061

(Sumber: peraturan menteri PUPR Republik Indonesia Nomor 1 tahun 2022)

Pemasangan 1 m ² Acian						
No	Uraian	Kode	Satuan	Koefisien	Harga Satuan	Jumlah Harga
A	TENAGA KERJA					
	Pekerja	L.01	OH	0.100	Rp 95,000	Rp 9,500
	Tukang Batu	L.02	OH	0.100	Rp 150,000	Rp 15,000
	Kepala Tukang Batu	L.03	OH	0.010	Rp 165,000	Rp 1,650
	Mandor Batu	L.10	OH	0.010	Rp 175,000	Rp 1,750
JUMLAH HARGA TENAGA KERJA						Rp 27,900
B	BAHAN					
	Semen Portland	M.18	Kg	3.2500	Rp 1,800	Rp 5,850
JUMLAH HARGA BAHAN						Rp 5,850
C	PERALATAN					
JUMLAH HARGA ALAT						
D	Jumlah (A+B+C)					Rp 33,750
E	Overhead & Profit (15% × D)					Rp 5,063
F	Harga Satuan Pekerjaan (D+E)					Rp 38,813

(Sumber: peraturan menteri PUPR Republik Indonesia Nomor 1 tahun 2022)

Pembuatan 1m' Kolom Praktis dan Balok Latei						
No	Uraian	Kode	Satuan	Koefisien	Harga Satuan	Jumlah Harga
A	TENAGA KERJA					
	Pekerja	L.01	OH	0.180	Rp 95,000	Rp 17,100
	Tukang Batu	L.02	OH	0.020	Rp 150,000	Rp 3,000
	Tukang Kayu	L.07	OH	0.020	Rp 150,000	Rp 3,000
	Tukang Besi	L.05	OH	0.020	Rp 150,000	Rp 3,000
	Mandor Batu	L.10	OH	0.009	Rp 175,000	Rp 1,575
	Mandor Kayu	L.11	OH	0.009	Rp 175,000	Rp 1,575
	Mandor Besi	L.12	OH	0.009	Rp 175,000	Rp 1,575
JUMLAH HARGA TENAGA KERJA						Rp 29,250
B	BAHAN					
	Kayu Kelas 3	M.17	M3	0.002	9000000	Rp 18,000
	Paku 5cm - 12 cm	M.10	Kg	0.01	21000	Rp 210
	Besi beton	M.04	Kg	3	12,000.00	Rp 36,000
	Kawat Beton	M.75	Kg	0.45	74,750.00	Rp 33,638
	Semen Portland	M.18	Kg	3.2500	Rp 1,800	Rp 5,850
	Pasir Pasang	M.15	M3	0.0060	Rp 232,000	Rp 1,392
	Kerikil	M.19	M3	0.0090	Rp 568,750	Rp 5,119
JUMLAH HARGA BAHAN						Rp 100,208
C	PERALATAN					
JUMLAH HARGA ALAT						
D	Jumlah (A+B+C)					Rp 129,458
E	Overhead & Profit (15% × D)					Rp 19,419
F	Harga Satuan Pekerjaan (D+E)					Rp 148,877

(Sumber: peraturan menteri PUPR Republik Indonesia Nomor 1 tahun 2022)

Pemasangan Keramik 60x60 (Polished)						
No	Uraian	Kode	Satuan	Koefisien	Harga Satuan	Jumlah Harga
A	TENAGA KERJA					
	Pekerja	L.01	OH	0.700	Rp 95,000	Rp 66,500
	Tukang Batu	L.02	OH	0.350	Rp 150,000	Rp 52,500
	Kepala Tukang Batu	L.03	OH	0.035	Rp 165,000	Rp 5,775
	Mandor Batu	L.10	OH	0.035	Rp 175,000	Rp 6,125
	JUMLAH HARGA TENAGA KERJA					Rp 130,900
B	BAHAN					
	Keramik 60x60 Polished	M.26	buah	3.1	42,975.00	Rp 133,223
	Semen Portland	M.18	Kg	9.6000	Rp 1,800	Rp 17,280
	Pasir pasang	M.15	M3	0.0450	Rp 232,000	Rp 10,440
	Semen Warna	M.27	Kg	1.5000	Rp 2,750	Rp 4,125
	JUMLAH HARGA BAHAN					Rp 165,068
C	PERALATAN					
	JUMLAH HARGA ALAT					
D	Jumlah (A+B+C)					Rp 295,968
E	Overhead & Profit (15% × D)					Rp 44,395
F	Harga Satuan Pekerjaan (D+E)					Rp 340,363

(Sumber: peraturan menteri PUPR Republik Indonesia Nomor 1 tahun 2022)

Pemasangan Keramik 30x30 per m2						
No	Uraian	Kode	Satuan	Koefisien	Harga Satuan	Jumlah Harga
A	TENAGA KERJA0.7					
	Pekerja	L.01	OH	0.700	Rp 95,000	Rp 66,500
	Tukang Batu	L.02	OH	0.350	Rp 150,000	Rp 52,500
	Kepala Tukang Batu	L.03	OH	0.035	Rp 165,000	Rp 5,775
	Mandor Batu	L.10	OH	0.035	Rp 175,000	Rp 6,125
	JUMLAH HARGA TENAGA KERJA					Rp 130,900
B	BAHAN					
	Ubin Keramik 30x30	M.32	dus	1.05	49500	Rp 51,975
	Semen Portland	M.18	Kg	10.0000	Rp 1,800	Rp 18,000
	Pasir pasang	M.15	M3	0.0450	Rp 232,000	Rp 10,440
	Semen Warna	M.27	Kg	0.5000	Rp 2,750	Rp 1,375
	JUMLAH HARGA BAHAN					Rp 81,790
C	PERALATAN					
	JUMLAH HARGA ALAT					
D	Jumlah (A+B+C)					Rp 212,690
E	Overhead & Profit (15% × D)					Rp 31,904
F	Harga Satuan Pekerjaan (D+E)					Rp 244,594

(Sumber: peraturan menteri PUPR Republik Indonesia Nomor 1 tahun 2022)

Pemasangan Plint 10x60 (1 m')						
No	Uraian	Kode	Satuan	Koefisien	Harga Satuan	Jumlah Harga
A	TENAGA KERJA					
	Pekerja	L.01	OH	0.090	Rp 95,000	Rp 8,550
	Tukang Batu	L.02	OH	0.090	Rp 150,000	Rp 13,500
	Kepala Tukang Batu	L.03	OH	0.009	Rp 165,000	Rp 1,485
	Mandor Batu	L.10	OH	0.005	Rp 175,000	Rp 875
	JUMLAH HARGA TENAGA KERJA					Rp 24,410
B	BAHAN					
	Plint 10 x 60	M.26	buah	1.7	Rp 58,000	Rp 98,600
	Semen Portland	M.18	Kg	1.1400	Rp 1,800	Rp 2,052

No	Uraian	Kode	Satuan	Koefisien	Harga Satuan	Jumlah Harga
	Pasir pasang	M.15	M3	0.0030	Rp 232,000	Rp 696
	Semen Warna	M.27	Kg	0.1000	Rp 2,750	Rp 275
	JUMLAH HARGA BAHAN					Rp 101,623
C	PERALATAN					
	JUMLAH HARGA ALAT					
D	Jumlah (A+B+C)					Rp 126,033
E	Overhead & Profit (15% × D)					Rp 18,905
F	Harga Satuan Pekerjaan (D+E)					Rp 144,938

(Sumber: peraturan menteri PUPR Republik Indonesia Nomor 1 tahun 2022)

Pemasangan plafond Gypsum t=9 mm per m2						
No	Uraian	Kode	Satuan	Koefisien	Harga Satuan	Jumlah Harga
A	TENAGA KERJA					
	Pekerja	L.01	OH	0.100	Rp 95,000	Rp 9,500
	Tukang Kayu	L.07	OH	0.050	Rp 150,000	Rp 7,500
	Kepala Tukang Kayu	L.06	OH	0.005	Rp 165,000	Rp 825
	Mandor Kayu	L.11	OH	0.005	Rp 175,000	Rp 875
	JUMLAH HARGA TENAGA KERJA					Rp 18,700
B	BAHAN					
	gypsum board (12x240x9)	M.33	Lembar	0.364	Rp 66,000	Rp 24,024
	Paku Sekrup	M.34	Kg	0.1100	Rp 19,090	Rp 2,100
	JUMLAH HARGA BAHAN					Rp 26,124
C	PERALATAN					
	JUMLAH HARGA ALAT					
D	Jumlah (A+B+C)					Rp 44,824
E	Overhead & Profit (15% × D)					Rp 6,724
F	Harga Satuan Pekerjaan (D+E)					Rp 51,547

(Sumber: peraturan menteri PUPR Republik Indonesia Nomor 28 tahun 2016)

Rangka Hollow Galvanis 40x40x3 mm per m2						
No	Uraian	Kode	Satuan	Koefisien	Harga Satuan	Jumlah Harga
A	TENAGA KERJA					
	Pekerja	L.01	OH	0.350	Rp 95,000	Rp 33,250
	Tukang Besi	L.05	OH	0.350	Rp 150,000	Rp 52,500
	Kepala Tukang Besi	L.04	OH	0.035	Rp 165,000	Rp 5,775
	Mandor Besi	L.12	OH	0.018	Rp 175,000	Rp 3,150
	JUMLAH HARGA TENAGA KERJA					Rp 94,675
B	BAHAN					
	Rangka hollow 40.40.3	M.35	M	4.000	Rp 4,500	Rp 18,000
	Assesoris (perkuatan & las dll)	M.105	0	1.000	Rp 18,000	Rp 18,000
	JUMLAH HARGA BAHAN					Rp 36,000
C	PERALATAN					
	JUMLAH HARGA ALAT					
D	Jumlah (A+B+C)					Rp 130,675
E	Overhead & Profit (15% × D)					Rp 19,601
F	Harga Satuan Pekerjaan (D+E)					Rp 150,276

(Sumber: peraturan menteri PUPR Republik Indonesia Nomor 28 tahun 2016)

List Plafond Gypsum 8 cm						
No	Uraian	Kode	Satuan	Koefisien	Harga Satuan	Jumlah Harga
A	TENAGA KERJA					
	Pekerja	L.01	OH	0.060	Rp 95,000	Rp 5,700
	Tukang Kayu	L.07	OH	0.060	Rp 150,000	Rp 9,000
	Kepala Tukang Kayu	L.06	OH	0.006	Rp 165,000	Rp 990
	Mandor Kayu	L.11	OH	0.003	Rp 175,000	Rp 525
	JUMLAH HARGA TENAGA KERJA					Rp 16,215
B	BAHAN					
	List Gypsum 8 cm	M.37	M	1.050	Rp 7,500	Rp 7,875
	Tepung Gypsum	M.38	Kg	0.150	Rp 3,750	Rp 563
	JUMLAH HARGA BAHAN					Rp 8,438
C	PERALATAN					
	JUMLAH HARGA ALAT					
D	Jumlah (A+B+C)					Rp 24,653
E	Overhead & Profit (15% × D)					Rp 3,698
F	Harga Satuan Pekerjaan (D+E)					Rp 28,350

Sumber: SNI 2839:2008 No.6.8

Pasang Closet Duduk (Lengkap Terpasang)						
No	Uraian	Kode	Satuan	Koefisien	Harga Satuan	Jumlah Harga
A	TENAGA KERJA					
	Pekerja	L.01	OH	3.300	Rp 95,000	Rp 313,500
	Tukang Batu	L.02	OH	1.100	Rp 150,000	Rp 165,000
	Kepala Tukang Batu	L.03	OH	0.010	Rp 165,000	Rp 1,650
	Mandor Batu	L.10	OH	0.160	Rp 175,000	Rp 28,000
	JUMLAH HARGA TENAGA KERJA					Rp 508,150
B	BAHAN					
	Closet Duduk TOTO CW638J	M.39	unit	1.050	Rp3,546,000	Rp 3,723,300
	Perlengkapan Closed(6%)	M.131	Ls	1.000	Rp 212,760	Rp 212,760
	JUMLAH HARGA BAHAN					Rp 3,936,060
C	PERALATAN					
	JUMLAH HARGA ALAT					
D	Jumlah (A+B+C)					Rp 4,444,210
E	Overhead & Profit (15% × D)					Rp 666,632
F	Harga Satuan Pekerjaan (D+E)					Rp 5,110,842

(Sumber: peraturan menteri PUPR Republik Indonesia Nomor 1 tahun 2022)

Pasang Urinoir (Lengkap Terpasang)						
No	Uraian	Kode	Satuan	Koefisien	Harga Satuan	Jumlah Harga
A	TENAGA KERJA					
	Pekerja	L.01	OH	1.000	Rp 95,000	Rp 95,000
	Tukang Batu	L.02	OH	1.000	Rp 150,000	Rp 150,000
	Kepala Tukang Batu	L.03	OH	0.100	Rp 165,000	Rp 16,500
	Mandor Batu	L.10	OH	0.050	Rp 175,000	Rp 8,750
	JUMLAH HARGA TENAGA KERJA					Rp 270,250
B	BAHAN					
	Urinoir Lengkap	M.45	Unit	1.000	Rp2,500,000	Rp 2,500,000
	Semen Portland	M.18	Kg	6.000	Rp 1,800	Rp 10,800
	Pasir Pasang	M.15	M3	0.010	Rp 232,000	Rp 2,320
	JUMLAH HARGA BAHAN					Rp 2,513,120
C	PERALATAN					
	JUMLAH HARGA ALAT					
D	Jumlah (A+B+C)					Rp 2,783,370

No	Uraian	Kode	Satuan	Koefisien	Harga Satuan	Jumlah Harga
E	Overhead & Profit (15% × D)					Rp 417,506
F	Harga Satuan Pekerjaan (D+E)					Rp 3,200,876

(Sumber: peraturan menteri PUPR Republik Indonesia Nomor 1 tahun 2022)

Pasang Partisi Urinoir - Toilet						
No	Uraian	Kode	Satuan	Koefisien	Harga Satuan	Jumlah Harga
A	TENAGA KERJA					
	Pekerja	L.01	OH	1.000	Rp 95,000	Rp 95,000
	Tukang Batu	L.02	OH	1.000	Rp 150,000	Rp 150,000
	Kepala Tukang Batu	L.03	OH	0.100	Rp 165,000	Rp 16,500
	Mandor Batu	L.10	OH	0.100	Rp 175,000	Rp 17,500
	JUMLAH HARGA TENAGA KERJA					Rp 279,000
B	BAHAN					
	Partisi Urinoir TOTO A100	M.51	Buah	1.000	Rp1,188,000	Rp 1,188,000
	Perlengkapan Partisi Urinoir (30%)	M.132	Ls	1.000	Rp 212,760	Rp 212,760
	Semen Portland	M.18	Kg	6.000	Rp 1,800	Rp 10,800
	Pasir Pasang	M.15	M3	0.010	Rp 232,000	Rp 2,320
	JUMLAH HARGA BAHAN					Rp 1,413,880
C	PERALATAN					
	JUMLAH HARGA ALAT					
D	Jumlah (A+B+C)					Rp 1,692,880
E	Overhead & Profit (15% × D)					Rp 253,932
F	Harga Satuan Pekerjaan (D+E)					Rp 1,946,812

Sumber: SNI 6.4 03-2835-2002

Pasang Cermin - Toilet						
No	Uraian	Kode	Satuan	Koefisien	Harga Satuan	Jumlah Harga
A	TENAGA KERJA					
	Pekerja	L.01	OH	0.015	Rp 95,000	Rp 1,425
	Tukang Kayu	L.07	OH	0.150	Rp 150,000	Rp 22,500
	Kepala Tukang Kayu	L.06	OH	0.015	Rp 165,000	Rp 2,475
	Mandor Kayu	L.11	OH	0.008	Rp 175,000	Rp 1,400
	JUMLAH HARGA TENAGA KERJA					Rp 27,800
B	BAHAN					
	Kaca Cermin 5 mm ex Asahi	M.52	M2	1.100	Rp 203,300	Rp 223,630
	Sealant	M.74	kg	0.050	Rp 55,886	Rp 2,794
	JUMLAH HARGA BAHAN					Rp 226,424
C	PERALATAN					
	JUMLAH HARGA ALAT					
D	Jumlah (A+B+C)					Rp 254,224
E	Overhead & Profit (15% × D)					Rp 38,134
F	Harga Satuan Pekerjaan (D+E)					Rp 292,358

(Sumber: peraturan menteri PUPR Republik Indonesia Nomor 1 tahun 2022)

Pasang Wastafel - Toilet (lengkap terpasang)						
No	Uraian	Kode	Satuan	Koefisien	Harga Satuan	Jumlah Harga
A	TENAGA KERJA					
	Pekerja	L.01	OH	1.200	Rp 95,000	Rp 114,000
	Tukang Batu	L.02	OH	1.450	Rp 150,000	Rp 217,500
	Kepala Tukang Batu	L.03	OH	0.150	Rp 165,000	Rp 24,750
	Mandor Batu	L.10	OH	0.100	Rp 175,000	Rp 17,500
	JUMLAH HARGA TENAGA KERJA					Rp 373,750
B	BAHAN					
	Wastafel Vanitory Monaco exAmstad	M.53	Buah	1.000	Rp1,130,800	Rp 1,130,800
	Perlengkapan(12% x Wastafel)		Ls	0.120	Rp1,130,800	Rp 135,696
	Semen Portland	M.18	Kg	6.000	Rp 1,800	Rp 10,800
	Pasir Pasang	M.15	M3	0.010	Rp 232,000	Rp 2,320
	JUMLAH HARGA BAHAN					Rp 1,279,616
C	PERALATAN					
	JUMLAH HARGA ALAT					
D	Jumlah (A+B+C)					Rp 1,653,366
E	Overhead & Profit (15% x D)					Rp 248,005
F	Harga Satuan Pekerjaan (D+E)					Rp 1,901,371

Pasang Jet Washer - Toilet						
No	Uraian	Kode	Satuan	Koefisien	Harga Satuan	Jumlah Harga
A	TENAGA KERJA					
	Pekerja	L.01	OH	0.010	Rp 95,000	Rp 950
	Tukang Batu	L.02	OH	0.100	Rp 150,000	Rp 15,000
	Kepala Tukang Batu	L.03	OH	0.010	Rp 165,000	Rp 1,650
	Mandor Batu	L.10	OH	0.008	Rp 175,000	Rp 1,400
	JUMLAH HARGA TENAGA KERJA					Rp 19,000
B	BAHAN					
	Jet Washer American Standard FFTP404-WTFB0	M.54	Buah	1.000	Rp 240,000	Rp 240,000
	Seal Tape	M.55	Buah	1.000	Rp 4,280	Rp 4,280
	JUMLAH HARGA BAHAN					Rp 244,280
C	PERALATAN					
	JUMLAH HARGA ALAT					
D	Jumlah (A+B+C)					Rp 263,280
E	Overhead & Profit (15% x D)					Rp 39,492
F	Harga Satuan Pekerjaan (D+E)					Rp 302,772

Pasangan Floor Drain Stainless - Toilet						
No	Uraian	Kode	Satuan	Koefisien	Harga Satuan	Jumlah Harga
A	TENAGA KERJA					
	Pekerja	L.01	OH	0.010	Rp 95,000	Rp 950
	Tukang Kayu	L.07	OH	0.100	Rp 150,000	Rp 15,000
	Kepala Tukang Kayu	L.06	OH	0.010	Rp 165,000	Rp 1,650
	Mandor Kayu	L.11	OH	0.005	Rp 175,000	Rp 875
	JUMLAH HARGA TENAGA KERJA					Rp 18,475
B	BAHAN					
	Floor Drain Stainless	M.56	Buah	1.000	Rp 157,000	Rp 157,000
	JUMLAH HARGA BAHAN					Rp 157,000
C	PERALATAN					
	JUMLAH HARGA ALAT					

No	Uraian	Kode	Satuan	Koefisien	Harga Satuan	Jumlah Harga
D	Jumlah (A+B+C)					Rp 175,475
E	Overhead & Profit (15% × D)					Rp 26,321
F	Harga Satuan Pekerjaan (D+E)					Rp 201,796

Pembuatan dan Pemasangan Kusen Pintu dan Jendela (M3) Kayu Kelas 1						
No	Uraian	Kode	Satuan	Koefisien	Harga Satuan	Jumlah Harga
A	TENAGA KERJA					
	Pekerja	L.01	OH	7.000	Rp 95,000	Rp 665,000
	Tukang Kayu	L.07	OH	21.000	Rp 150,000	Rp 3,150,000
	Kepala Tukang Kayu	L.06	OH	2.100	Rp 165,000	Rp 346,500
	Mandor Kayu	L.11	OH	0.350	Rp 175,000	Rp 61,250
	JUMLAH HARGA TENAGA KERJA					Rp 4,222,750
B	BAHAN					
	Kayu Untuk Kusen Kelas 1		M3	1.100	Rp5,000,000	Rp 5,500,000
	Paku 10 cm		kg	1.250	Rp 17,000	Rp 21,250
	Lem Kayu		kg	1.000	Rp 42,800	Rp 42,800
	JUMLAH HARGA BAHAN					Rp 5,564,050
C	PERALATAN					
	JUMLAH HARGA ALAT					
D	Jumlah (A+B+C)					Rp 9,786,800
E	Overhead & Profit (15% × D)					Rp 1,468,020
F	Harga Satuan Pekerjaan (D+E)					Rp 11,254,820

Finishing Melamin Kusen Daun Pintu Jendela (M2)						
No	Uraian	Kode	Satuan	Koefisien	Harga Satuan	Jumlah Harga
A	TENAGA KERJA					
	Pekerja	L.01	OH	0.500	Rp 95,000	Rp 47,500
	Tukang Kayu	L.07	OH	0.500	Rp 150,000	Rp 75,000
	Kepala Tukang Kayu	L.06	OH	0.050	Rp 165,000	Rp 8,250
	Mandor Kayu	L.11	OH	0.025	Rp 175,000	Rp 4,375
	JUMLAH HARGA TENAGA KERJA					Rp 135,125
B	BAHAN					
	Wood Filler		kg	0.150	Rp 53,500	Rp 8,025
	Woodstain		Liter	0.250	Rp 69,550	Rp 17,388
	Sending Sealer		Liter	0.250	Rp 69,550	Rp 17,388
	Melamin Top Coat		Liter	0.250	Rp 82,000	Rp 20,500
	Thinner		Liter	0.500	Rp 32,500	Rp 16,250
	Amplas		Lembar	0.500	Rp 4,900	Rp 2,450
	Alat Bantu (Alat semprot dll)		Ls	1.000	Rp 45,000	Rp 45,000
	JUMLAH HARGA BAHAN					Rp 127,000
C	PERALATAN					
	JUMLAH HARGA ALAT					
D	Jumlah (A+B+C)					Rp 262,125
E	Overhead & Profit (15% × D)					Rp 39,319
F	Harga Satuan Pekerjaan (D+E)					Rp 301,444

Pasang Kaca Bening 5 mm						
No	Uraian	Kode	Satuan	Koefisien	Harga Satuan	Jumlah Harga
A	TENAGA KERJA					
	Pekerja	L.01	OH	0.015	Rp 95,000	Rp 1,425
	Tukang Kayu	L.07	OH	0.150	Rp 150,000	Rp 22,500
	Kepala Tukang Kayu	L.06	OH	0.015	Rp 165,000	Rp 2,475
	Mandor Kayu	L.11	OH	0.008	Rp 175,000	Rp 1,400
	JUMLAH HARGA TENAGA KERJA					Rp 27,800
B	BAHAN					
	Kaca Bening 5 mm		M2	1.100	Rp 175,000	Rp 192,500
	Sealant		kg	0.050	Rp 55,886	Rp 2,794
	JUMLAH HARGA BAHAN					Rp 195,294
C	PERALATAN					
	JUMLAH HARGA ALAT					
D	Jumlah (A+B+C)					Rp 223,094
E	Overhead & Profit (15% × D)					Rp 33,464
F	Harga Satuan Pekerjaan (D+E)					Rp 256,558

Fabrikasi dan Pemasangan Hollow 40 x 40 x 1,2 mm (M') Untuk Railing						
No	Uraian	Kode	Satuan	Koefisien	Harga Satuan	Jumlah Harga
A	TENAGA KERJA					
	Pekerja	L.01	OH	0.028	Rp 95,000	Rp 2,660
	Tukang Besi	L.05	OH	0.060	Rp 150,000	Rp 9,000
	Kepala Tukang Besi	L.04	OH	0.006	Rp 165,000	Rp 990
	Mandor Besi	L.12	OH	0.002	Rp 175,000	Rp 350
	JUMLAH HARGA TENAGA KERJA					Rp 13,000
B	BAHAN					
	Besi Hollow 40x40x1.2 mm	M.82	M'	1.050	Rp 34,167	Rp 35,875
	Kawat Las	M.79	kg	0.006	Rp 56,000	Rp 336
	Solar	M.80	liter	0.005	Rp 6,800	Rp 34
	Minyak Pelumas	M.81	liter	0.001	Rp 120,000	Rp 120
	JUMLAH HARGA BAHAN					Rp 36,365
C	PERALATAN					
	Sewa Alat Welding (Minimal 5 Jam)	E.11	Hari	0.026	Rp 544,000	Rp 14,280
	JUMLAH HARGA ALAT					
D	Jumlah (A+B+C)					Rp 63,645
E	Overhead & Profit (15% × D)					Rp 9,547
F	Harga Satuan Pekerjaan (D+E)					Rp 73,192

Pengecatan Besi (M2)						
No	Uraian	Kode	Satuan	Koefisien	Harga Satuan	Jumlah Harga
A	TENAGA KERJA					
	Pekerja	L.01	OH	0.020	Rp 95,000	Rp 1,900
	Tukang Cat	L.09	OH	0.060	Rp 150,000	Rp 9,000
	Kepala Tukang Cat	L.08	OH	0.004	Rp 165,000	Rp 660
	Mandor Cat	L.13	OH	0.003	Rp 175,000	Rp 525
	JUMLAH HARGA TENAGA KERJA					Rp 12,085
B	BAHAN					
	Cat Minyak Dulux V-Gloss	M.83	kg	0.100	Rp 91,000	Rp 9,100
	JUMLAH HARGA BAHAN					Rp 9,100
C	PERALATAN					

No	Uraian	Kode	Satuan	Koefisien	Harga Satuan	Jumlah Harga
JUMLAH HARGA ALAT						
D	Jumlah (A+B+C)					Rp 21,185
E	Overhead & Profit (15% × D)					Rp 3,178
F	Harga Satuan Pekerjaan (D+E)					Rp 24,363

Pasang Casement 8" (Buah)						
No	Uraian	Kode	Satuan	Koefisien	Harga Satuan	Jumlah Harga
A	TENAGA KERJA					
	Pekerja	L.01	OH	0.010	Rp 95,000	Rp 950
	Tukang Kayu	L.07	OH	0.100	Rp 150,000	Rp 15,000
	Kepala Tukang Kayu	L.06	OH	0.010	Rp 165,000	Rp 1,650
	Mandor Kayu	L.11	OH	0.001	Rp 175,000	Rp 88
JUMLAH HARGA TENAGA KERJA						Rp 17,688
B	BAHAN					
	Casement 8"	M.84	Pasang	1.000	Rp 72,750	Rp 72,750
JUMLAH HARGA BAHAN						Rp 72,750
C	PERALATAN					
JUMLAH HARGA ALAT						
D	Jumlah (A+B+C)					Rp 90,438
E	Overhead & Profit (15% × D)					Rp 13,566
F	Harga Satuan Pekerjaan (D+E)					Rp 104,003

Pemasangan Keramik 60x60 (Unpolished)						
No	Uraian	Kode	Satuan	Koefisien	Harga Satuan	Jumlah Harga
A	TENAGA KERJA					
	Pekerja	L.01	OH	0.700	Rp 95,000	Rp 66,500
	Tukang Batu	L.02	OH	0.350	Rp 150,000	Rp 52,500
	Kepala Tukang Batu	L.03	OH	0.035	Rp 165,000	Rp 5,775
	Mandor Batu	L.10	OH	0.035	Rp 175,000	Rp 6,125
JUMLAH HARGA TENAGA KERJA						Rp 130,900
B	BAHAN					
	Keramik 60x60 Unpolished	M.78	buah	3.1	Rp 34,000	Rp 105,400
	Semen Portland	M.18	Kg	9.6000	Rp 1,800	Rp 17,280
	Pasir pasang	M.15	M3	0.0450	Rp 232,000	Rp 10,440
	Semen Warna	M.27	Kg	1.5000	Rp 2,750	Rp 4,125
JUMLAH HARGA BAHAN						Rp 137,245
C	PERALATAN					
JUMLAH HARGA ALAT						
D	Jumlah (A+B+C)					Rp 268,145
E	Overhead & Profit (15% × D)					Rp 40,222
F	Harga Satuan Pekerjaan (D+E)					Rp 308,367

Pemasangan Keramik dinding 30 x 60 km/wc						
No	Uraian	Kode	Satuan	Koefisien	Harga Satuan	Jumlah Harga
A	TENAGA KERJA					
	Pekerja	L.01	OH	0.900	Rp 95,000	Rp 85,500
	Tukang Batu	L.02	OH	0.450	Rp 150,000	Rp 67,500

No	Uraian	Kode	Satuan	Koefisien	Harga Satuan	Jumlah Harga
	Kepala Tukang Batu	L.03	OH	0.045	Rp 165,000	Rp 7,425
	Mandor Batu	L.10	OH	0.045	Rp 175,000	Rp 7,875
	JUMLAH HARGA TENAGA KERJA					Rp 168,300
B	BAHAN					
	Keramik Dinding 30x60	M.85	M2	1.06	Rp 156,000	Rp 165,360
	Semen Portland	M.18	Kg	9.6000	Rp 1,800	Rp 17,280
	Pasir pasang	M.15	M3	0.0180	Rp 232,000	Rp 4,176
	Semen Warna	M.27	Kg	0.9700	Rp 2,750	Rp 2,668
	JUMLAH HARGA BAHAN					Rp 189,484
C	PERALATAN					
	JUMLAH HARGA ALAT					
D	Jumlah (A+B+C)					Rp 357,784
E	Overhead & Profit (15% × D)					Rp 53,668
F	Harga Satuan Pekerjaan (D+E)					Rp 411,451

Pemasangan Partisi Toilet (M2)						
No	Uraian	Kode	Satuan	Koefisien	Harga Satuan	Jumlah Harga
A	TENAGA KERJA					
	Pekerja	L.01	OH	0.250	Rp 95,000	Rp 23,750
	Tukang Besi	L.05	OH	0.250	Rp 150,000	Rp 37,500
	Kepala Tukang Besi	L.04	OH	0.025	Rp 165,000	Rp 4,125
	Mandor Besi	L.12	OH	0.013	Rp 175,000	Rp 2,275
	JUMLAH HARGA TENAGA KERJA					Rp 67,650
B	BAHAN					
	Rangka hollow 40.40.3	M.35	M2	3.500	Rp 4,500	Rp 15,750
	Perlengkapan Partisi Toilet (100%)	M.133	ls	1.000	Rp 15,750	Rp 15,750
	Sekat PVC 0.5 mm	M.86	M2	1.000	Rp 80,000	Rp 80,000
	Grendel Pintu PVC	M.87	Buah	1.000	Rp 2,000	Rp 2,000
	JUMLAH HARGA BAHAN					Rp 113,500
C	PERALATAN					
	JUMLAH HARGA ALAT					
D	Jumlah (A+B+C)					Rp 181,150
E	Overhead & Profit (15% × D)					Rp 27,173
F	Harga Satuan Pekerjaan (D+E)					Rp 208,323

Pemasangan Daun Pintu Tipe 1 + Aksesoris						
No	Uraian	Kode	Satuan	Koefisien	Harga Satuan	Jumlah Harga
A	TENAGA KERJA					
	Pekerja	L.01	OH	0.190	Rp 95,000	Rp 18,050
	Tukang Kayu	L.07	OH	0.190	Rp 150,000	Rp 28,500
	Kepala Tukang Kayu	L.06	OH	0.040	Rp 165,000	Rp 6,600
	Mandor Kayu	L.11	OH	0.011	Rp 175,000	Rp 1,925
	JUMLAH HARGA TENAGA KERJA					Rp 55,075
B	BAHAN					
	Daun Pintu Tipe 1 (Kayu Kamper Samarinda)	M.88	Unit	1.000	Rp5,426,400	Rp 5,426,400
	Engsel Stainless Stell 5"	M.63	buah	6.000	Rp 69,500	Rp 417,000
	Handle Tipe 1	M.65	buah	2.000	Rp 240,000	Rp 480,000
	JUMLAH HARGA BAHAN					Rp 6,323,400

No	Uraian	Kode	Satuan	Koefisien	Harga Satuan	Jumlah Harga
C	PERALATAN					
	JUMLAH HARGA ALAT					
D	Jumlah (A+B+C)					Rp 6,378,475
E	Overhead & Profit (15% × D)					Rp 956,771
F	Harga Satuan Pekerjaan (D+E)					Rp 7,335,246

Pemasangan Daun Pintu Tipe 2 + Aksesoris						
No	Uraian	Kode	Satuan	Koefisien	Harga Satuan	Jumlah Harga
A	TENAGA KERJA					
	Pekerja	L.01	OH	0.190	Rp 95,000	Rp 18,050
	Tukang Kayu	L.07	OH	0.190	Rp 150,000	Rp 28,500
	Kepala Tukang Kayu	L.06	OH	0.040	Rp 165,000	Rp 6,600
	Mandor Kayu	L.11	OH	0.011	Rp 175,000	Rp 1,925
	JUMLAH HARGA TENAGA KERJA					Rp 55,075
B	BAHAN					
	Daun Pintu Tipe 2 (Kayu Kamper Samarinda)	M.89	Unit	1.000	Rp3,876,000	Rp 3,876,000
	Engsel Stainless Stell 5"	M.63	buah	6.000	Rp 69,500	Rp 417,000
	Handle Tipe 1	M.65	buah	2.000	Rp 240,000	Rp 480,000
	JUMLAH HARGA BAHAN					Rp 4,773,000
C	PERALATAN					
	JUMLAH HARGA ALAT					
D	Jumlah (A+B+C)					Rp 4,828,075
E	Overhead & Profit (15% × D)					Rp 724,211
F	Harga Satuan Pekerjaan (D+E)					Rp 5,552,286

Pemasangan Daun Pintu Tipe 3 + Aksesoris						
No	Uraian	Kode	Satuan	Koefisien	Harga Satuan	Jumlah Harga
A	TENAGA KERJA					
	Pekerja	L.01	OH	0.095	Rp 95,000	Rp 9,025
	Tukang Kayu	L.07	OH	0.095	Rp 150,000	Rp 14,250
	Kepala Tukang Kayu	L.06	OH	0.020	Rp 165,000	Rp 3,300
	Mandor Kayu	L.11	OH	0.006	Rp 175,000	Rp 963
	JUMLAH HARGA TENAGA KERJA					Rp 27,538
B	BAHAN					
	Daun Pintu Tipe 3 (Kayu Kamper Samarinda)	M.90	Unit	1.000	Rp2,907,000	Rp 2,907,000
	Engsel Stainless Stell 5"	M.63	buah	3.000	Rp 69,500	Rp 208,500
	Handle Tipe 2	M.64	buah	1.000	Rp 128,000	Rp 128,000
	JUMLAH HARGA BAHAN					Rp 3,243,500
C	PERALATAN					
	JUMLAH HARGA ALAT					
D	Jumlah (A+B+C)					Rp 3,271,038
E	Overhead & Profit (15% × D)					Rp 490,656
F	Harga Satuan Pekerjaan (D+E)					Rp 3,761,693

Pemasangan Daun Pintu Tipe 4 + Aksesoris						
No	Uraian	Kode	Satuan	Koefisien	Harga Satuan	Jumlah Harga
A	TENAGA KERJA					
	Pekerja	L.01	OH	0.095	Rp 95,000	Rp 9,025
	Tukang Kayu	L.07	OH	0.095	Rp 150,000	Rp 14,250
	Kepala Tukang Kayu	L.06	OH	0.020	Rp 165,000	Rp 3,300
	Mandor Kayu	L.11	OH	0.006	Rp 175,000	Rp 963
	JUMLAH HARGA TENAGA KERJA					Rp 27,538
B	BAHAN					
	Daun Pintu Tipe 4 (Kayu Kamper Samarinda)	M.91	Unit	1.000	Rp1,938,000	Rp 1,938,000
	Engsel Stainless Stell 4"	M.62	buah	3.000	Rp 37,000	Rp 111,000
	Handle Tipe 2	M.64	buah	1.000	Rp 128,000	Rp 128,000
	JUMLAH HARGA BAHAN					Rp 2,177,000
C	PERALATAN					
	JUMLAH HARGA ALAT					
D	Jumlah (A+B+C)					Rp 2,204,538
E	Overhead & Profit (15% × D)					Rp 330,681
F	Harga Satuan Pekerjaan (D+E)					Rp 2,535,218

Pemasangan Daun Pintu Tipe 5 + Aksesoris						
No	Uraian	Kode	Satuan	Koefisien	Harga Satuan	Jumlah Harga
A	TENAGA KERJA					
	Pekerja	L.01	OH	0.095	Rp 95,000	Rp 9,025
	Tukang Kayu	L.07	OH	0.095	Rp 150,000	Rp 14,250
	Kepala Tukang Kayu	L.06	OH	0.020	Rp 165,000	Rp 3,300
	Mandor Kayu	L.11	OH	0.006	Rp 175,000	Rp 963
	JUMLAH HARGA TENAGA KERJA					Rp 27,538
B	BAHAN					
	Daun Pintu Tipe 5 (Kayu Kamper Samarinda)	M.92	Unit	1.000	Rp1,550,400	Rp 1,550,400
	Engsel Stainless Stell 4"	M.62	buah	3.000	Rp 37,000	Rp 111,000
	Handle Tipe 2	M.64	buah	1.000	Rp 128,000	Rp 128,000
	JUMLAH HARGA BAHAN					Rp 1,789,400
C	PERALATAN					
	JUMLAH HARGA ALAT					
D	Jumlah (A+B+C)					Rp 1,816,938
E	Overhead & Profit (15% × D)					Rp 272,541
F	Harga Satuan Pekerjaan (D+E)					Rp 2,089,478

Pemasangan Daun Jendela Tipe 1 + Aksesoris						
No	Uraian	Kode	Satuan	Koefisien	Harga Satuan	Jumlah Harga
A	TENAGA KERJA					
	Pekerja	L.01	OH	0.515	Rp 95,000	Rp 48,925
	Tukang Kayu	L.07	OH	0.650	Rp 150,000	Rp 97,500
	Kepala Tukang Kayu	L.06	OH	0.065	Rp 165,000	Rp 10,725
	Mandor Kayu	L.11	OH	0.033	Rp 175,000	Rp 5,775
	JUMLAH HARGA TENAGA KERJA					Rp 162,925
B	BAHAN					
	Daun Jendela Tipe 1 (Kayu Kamper Samarinda)	M.93	Unit	1.000	Rp 472,340	Rp 472,340
	Kaca Bening 5 mm	M.73	M2	1.100	Rp 175,000	Rp 192,500
	Sealant	M.74	kg	0.050	Rp 55,886	Rp 2,794
	JUMLAH HARGA BAHAN					Rp 667,634

No	Uraian	Kode	Satuan	Koefisien	Harga Satuan	Jumlah Harga
C	PERALATAN					
	JUMLAH HARGA ALAT					
D	Jumlah (A+B+C)					Rp 830,559
E	Overhead & Profit (15% × D)					Rp 124,584
F	Harga Satuan Pekerjaan (D+E)					Rp 955,143

Pemasangan Daun Jendela Tipe 2 + Aksesoris						
No	Uraian	Kode	Satuan	Koefisien	Harga Satuan	Jumlah Harga
A	TENAGA KERJA					
	Pekerja	L.01	OH	0.515	Rp 95,000	Rp 48,925
	Tukang Kayu	L.07	OH	0.650	Rp 150,000	Rp 97,500
	Kepala Tukang Kayu	L.06	OH	0.065	Rp 165,000	Rp 10,725
	Mandor Kayu	L.11	OH	0.033	Rp 175,000	Rp 5,775
	JUMLAH HARGA TENAGA KERJA					Rp 162,925
B	BAHAN					
	Daun Jendela Tipe 2 (Kayu Kamper Samarinda)	M.94	Unit	1.000	Rp 319,200	Rp 319,200
	Kaca Bening 5 mm	M.73	M2	1.100	Rp 175,000	Rp 192,500
	Sealant	M.74	kg	0.050	Rp 55,886	Rp 2,794
	JUMLAH HARGA BAHAN					Rp 514,494
C	PERALATAN					
	JUMLAH HARGA ALAT					
D	Jumlah (A+B+C)					Rp 677,419
E	Overhead & Profit (15% × D)					Rp 101,613
F	Harga Satuan Pekerjaan (D+E)					Rp 779,032

Pemasangan Daun Jendela Tipe 3 + Aksesoris						
No	Uraian	Kode	Satuan	Koefisien	Harga Satuan	Jumlah Harga
A	TENAGA KERJA					
	Pekerja	L.01	OH	0.515	Rp 95,000	Rp 48,925
	Tukang Kayu	L.07	OH	0.650	Rp 150,000	Rp 97,500
	Kepala Tukang Kayu	L.06	OH	0.065	Rp 165,000	Rp 10,725
	Mandor Kayu	L.11	OH	0.033	Rp 175,000	Rp 5,775
	JUMLAH HARGA TENAGA KERJA					Rp 162,925
B	BAHAN					
	Daun Jendela Tipe 3 (Kayu Kamper Samarinda)	M.95	Unit	1.000	Rp 269,040	Rp 269,040
	Kaca Bening 5 mm	M.73	M2	1.100	Rp 175,000	Rp 192,500
	Sealant	M.74	kg	0.050	Rp 55,886	Rp 2,794
	JUMLAH HARGA BAHAN					Rp 464,334
C	PERALATAN					
	JUMLAH HARGA ALAT					
D	Jumlah (A+B+C)					Rp 627,259
E	Overhead & Profit (15% × D)					Rp 94,089
F	Harga Satuan Pekerjaan (D+E)					Rp 721,348

Pemasangan Boven + Aksesoris						
No	Uraian	Kode	Satuan	Koefisien	Harga Satuan	Jumlah Harga
A	TENAGA KERJA					
	Pekerja	L.01	OH	0.525	Rp 95,000	Rp 49,875
	Tukang Kayu	L.07	OH	0.750	Rp 150,000	Rp 112,500
	Kepala Tukang Kayu	L.06	OH	0.075	Rp 165,000	Rp 12,375
	Mandor Kayu	L.11	OH	0.034	Rp 175,000	Rp 5,863
	JUMLAH HARGA TENAGA KERJA					Rp 180,613
B	BAHAN					
	Daun Boven (Kayu Kamper Samarinda)	M.96	Unit	1.000	Rp 209,380	Rp 209,380
	Kaca Bening 5 mm	M.73	M2	1.100	Rp 175,000	Rp 192,500
	Sealant	M.74	kg	0.050	Rp 55,886	Rp 2,794
	Casement 8"	M.84	Pasang	1.000	Rp 72,750	Rp 72,750
	JUMLAH HARGA BAHAN					Rp 477,424
C	PERALATAN					
	JUMLAH HARGA ALAT					
D	Jumlah (A+B+C)					Rp 658,037
E	Overhead & Profit (15% × D)					Rp 98,706
F	Harga Satuan Pekerjaan (D+E)					Rp 756,742

Pemasangan plafond PVC t = 8 mm						
No	Uraian	Kode	Satuan	Koefisien	Harga Satuan	Jumlah Harga
A	TENAGA KERJA					
	Pekerja	L.01	OH	0.150	Rp 95,000	Rp 14,250
	Tukang Kayu	L.07	OH	0.250	Rp 150,000	Rp 37,500
	Kepala Tukang Kayu	L.06	OH	0.025	Rp 165,000	Rp 4,125
	Mandor Kayu	L.11	OH	0.075	Rp 175,000	Rp 13,125
	JUMLAH HARGA TENAGA KERJA					Rp 69,000
B	BAHAN					
	Plavon PVC Indahfon t = 8 mm	M.99	M2	1.05	Rp 150,500	Rp 158,025
	Screw	M.100	Buah	18.0000	Rp 60	Rp 1,080
	JUMLAH HARGA BAHAN					Rp 159,105
C	PERALATAN					
	JUMLAH HARGA ALAT					
D	Jumlah (A+B+C)					Rp 228,105
E	Overhead & Profit (15% × D)					Rp 34,216
F	Harga Satuan Pekerjaan (D+E)					Rp 262,321

List Plafond PVC 3 cm						
No	Uraian	Kode	Satuan	Koefisien	Harga Satuan	Jumlah Harga
A	TENAGA KERJA					
	Pekerja	L.01	OH	0.100	Rp 95,000	Rp 9,500
	Tukang Kayu	L.07	OH	0.050	Rp 150,000	Rp 7,500
	Kepala Tukang Kayu	L.06	OH	0.005	Rp 165,000	Rp 825
	Mandor Kayu	L.11	OH	0.005	Rp 175,000	Rp 875
	JUMLAH HARGA TENAGA KERJA					Rp 18,700
B	BAHAN					
	List PVC Shunda 3 cm	M.101	M	1.050	Rp 20,500	Rp 21,525
	Screw	M.100	Buah	6.000	Rp 60	Rp 360
	JUMLAH HARGA BAHAN					Rp 21,885

No	Uraian	Kode	Satuan	Koefisien	Harga Satuan	Jumlah Harga
C	PERALATAN					
	JUMLAH HARGA ALAT					
D	Jumlah (A+B+C)					Rp 40,585
E	Overhead & Profit (15% × D)					Rp 6,088
F	Harga Satuan Pekerjaan (D+E)					Rp 46,673

Pemasangan Stepnosing untuk tangga (M')						
No	Uraian	Kode	Satuan	Koefisien	Harga Satuan	Jumlah Harga
A	TENAGA KERJA					
	Pekerja	L.01	OH	0.090	Rp 95,000	Rp 8,550
	Tukang Batu	1.02	OH	0.090	Rp 150,000	Rp 13,500
	Kepala Tukang Batu	1.03	OH	0.009	Rp 165,000	Rp 1,485
	Mandor Batu	1.10	OH	0.005	Rp 175,000	Rp 875
	JUMLAH HARGA TENAGA KERJA					Rp 24,410
B	BAHAN					
	Stepnosing 10x60	M.103	Buah	2.000	Rp 14,500	Rp 29,000
	Semen Portland	M.18	Kg	1.140	Rp 1,800	Rp 2,052
	Pasir Pasang	M.15	m ³	0.003	Rp 232,000	Rp 696
	Semen Warna	M.27	kg	0.006	Rp 2,750	Rp 17
	JUMLAH HARGA BAHAN					Rp 31,765
C	PERALATAN					
	JUMLAH HARGA ALAT					
D	Jumlah (A+B+C)					Rp 56,175
E	Overhead & Profit (15% × D)					Rp 8,426
F	Harga Satuan Pekerjaan (D+E)					Rp 64,601

Sponengan m1						
No	Uraian	Kode	Satuan	Koefisien	Harga Satuan	Jumlah Harga
A	TENAGA KERJA					
	Pekerja	L.01	OH	0.057	Rp 95,000	Rp 5,415
	Tukang Batu	1.02	OH	0.038	Rp 150,000	Rp 5,700
	Kepala Tukang Batu	1.03	OH	0.004	Rp 165,000	Rp 627
	Mandor Batu	1.10	OH	0.002	Rp 175,000	Rp 350
	JUMLAH HARGA TENAGA KERJA					Rp 12,092
B	BAHAN					
	Semen Portland	M.18	Kg	0.500	Rp 1,800	Rp 900
	Pasir Pasang	M.15	m ³	0.013	Rp 232,000	Rp 3,016
	JUMLAH HARGA BAHAN					Rp 3,916
C	PERALATAN					
	JUMLAH HARGA ALAT					
D	Jumlah (A+B+C)					Rp 16,008
E	Overhead & Profit (15% × D)					Rp 2,401
F	Harga Satuan Pekerjaan (D+E)					Rp 18,409

Pengecatan 1m2 Tembok baru Interior dan plafon (1 lapis Plamuur, 1 Lapis Cat Dasar, 2 Lapis Cat Penutup)						
No	Uraian	Kode	Satuan	Koefisien	Harga Satuan	Jumlah Harga
A	TENAGA KERJA					
	Pekerja	L.01	OH	0.020	Rp 95,000	Rp 1,900
	Tukang Cat	L.09	OH	0.063	Rp 150,000	Rp 9,450
	Kepala Tukang Cat	L.08	OH	0.006	Rp 165,000	Rp 1,040
	Mandor Cat	L.13	OH	0.003	Rp 175,000	Rp 525
	JUMLAH HARGA TENAGA KERJA					Rp 12,915
B	BAHAN					
	Plamuur	M.46	Kg	0.100	Rp 16,520	Rp 1,652
	Cat Dasar Interior	M.47	Kg	0.100	Rp 45,900	Rp 4,590
	Cat Penutup Interior	M.48	Kg	0.260	Rp 49,140	Rp 12,776
	JUMLAH HARGA BAHAN					Rp 19,018
C	PERALATAN					
	JUMLAH HARGA ALAT					
D	Jumlah (A+B+C)					Rp 31,933
E	Overhead & Profit (15% × D)					Rp 4,790
F	Harga Satuan Pekerjaan (D+E)					Rp 36,723

Pengecatan 1m2 Tembok baru Exterior (1 lapis Plamuur, 1 Lapis Cat Dasar, 2 Lapis Cat Penutup)						
No	Uraian	Kode	Satuan	Koefisien	Harga Satuan	Jumlah Harga
A	TENAGA KERJA					
	Pekerja	L.01	OH	0.020	Rp 95,000	Rp 1,900
	Tukang Cat	L.09	OH	0.063	Rp 150,000	Rp 9,450
	Kepala Tukang Cat	L.08	OH	0.006	Rp 165,000	Rp 1,040
	Mandor Cat	L.13	OH	0.003	Rp 175,000	Rp 525
	JUMLAH HARGA TENAGA KERJA					Rp 12,915
B	BAHAN					
	Plamuur	M.46	Kg	0.100	Rp 16,520	Rp 1,652
	Cat Dasar Exterior	M.49	Kg	0.100	Rp 44,047	Rp 4,405
	Cat Penutup Exterior	M.50	Kg	0.260	Rp 125,680	Rp 32,677
	JUMLAH HARGA BAHAN					Rp 38,734
C	PERALATAN					
	JUMLAH HARGA ALAT					
D	Jumlah (A+B+C)					Rp 51,648
E	Overhead & Profit (15% × D)					Rp 7,747
F	Harga Satuan Pekerjaan (D+E)					Rp 59,395

Pemasangan 1 m' Pipa PVC kelas AW dia 3/4"						
No	Uraian	Kode	Satuan	Koefisien	Harga Satuan	Jumlah Harga
A	TENAGA KERJA					
	Pekerja	L.01	OH	0.0360	Rp 95,000	Rp 3,420
	Tukang Batu	L.02	OH	0.0600	Rp 150,000	Rp 9,000
	Kepala Tukang Batu	L.03	OH	0.0060	Rp 165,000	Rp 990
	Mandor Batu	L.10	OH	0.0020	Rp 175,000	Rp 350
	JUMLAH HARGA TENAGA KERJA					Rp 13,760
B	BAHAN					
	Pipa PVC Kelas dia 20 mm	M.106	M	1.2000	Rp 9,075	Rp 10,890
	Perlengkapan Pipa PVC Kelas AW dia 20 (12.5%)	M.107	0	1.0000	Rp 1,134	Rp 1,134
	JUMLAH HARGA BAHAN					Rp 12,024

No	Uraian	Kode	Satuan	Koefisien	Harga Satuan	Jumlah Harga
C	PERALATAN					
	JUMLAH HARGA ALAT					
D	Jumlah (A+B+C)					Rp 25,784
E	Overhead & Profit (15% × D)					Rp 3,868
F	Harga Satuan Pekerjaan (D+E)					Rp 29,652

Pemasangan 1 m' Pipa PVC kelas AW dia 1"						
No	Uraian	Kode	Satuan	Koefisien	Harga Satuan	Jumlah Harga
A	TENAGA KERJA					
	Pekerja	L.01	OH	0.0360	Rp 95,000	Rp 3,420
	Tukang Batu	L.02	OH	0.0600	Rp 150,000	Rp 9,000
	Kepala Tukang Batu	L.03	OH	0.0060	Rp 165,000	Rp 990
	Mandor Batu	L.10	OH	0.0020	Rp 175,000	Rp 350
	JUMLAH HARGA TENAGA KERJA					Rp 13,760
B	BAHAN					
	Pipa PVC Kelas dia 25 mm	M.118	M	1.2000	Rp 12,425	Rp 14,910
	Perlengkapan Pipa PVC Kelas AW dia 25 (12.5%)	M.119	M	1.0000	Rp 1,553	Rp 1,553
	JUMLAH HARGA BAHAN					Rp 16,463
C	PERALATAN					
	JUMLAH HARGA ALAT					
D	Jumlah (A+B+C)					Rp 30,223
E	Overhead & Profit (15% × D)					Rp 4,533
F	Harga Satuan Pekerjaan (D+E)					Rp 34,757

Pemasangan 1 m'PVC kelas AW dia. 110- 4"						
No	Uraian	Kode	Satuan	Koefisien	Harga Satuan	Jumlah Harga
A	TENAGA KERJA					
	Pekerja	L.01	OH	0.0810	Rp 95,000	Rp 7,695
	Tukang Batu	L.02	OH	0.1350	Rp 150,000	Rp 20,250
	Kepala Tukang Batu	L.03	OH	0.0135	Rp 165,000	Rp 2,228
	Mandor Batu	L.10	OH	0.0040	Rp 175,000	Rp 700
	JUMLAH HARGA TENAGA KERJA					Rp 30,873
B	BAHAN					
	PVC Kelas AW dia. 110- 4"	M.108	M	1.2000	Rp 92,575	Rp 111,090
	Perlengkapan Pipa PVC Kleas AW dia 110 (12.5%)	M.109	0	1.0000	Rp 11,572	Rp 11,572
	JUMLAH HARGA BAHAN					Rp 122,662
C	PERALATAN					
	JUMLAH HARGA ALAT					
D	Jumlah (A+B+C)					Rp 153,534
E	Overhead & Profit (15% × D)					Rp 23,030
F	Harga Satuan Pekerjaan (D+E)					Rp 176,565

Pemasangan 1 m'PVC kelas AW dia. 75- 3"						
No	Uraian	Kode	Satuan	Koefisien	Harga Satuan	Jumlah Harga
A	TENAGA KERJA					
	Pekerja	L.01	OH	0.0810	Rp 95,000	Rp 7,695
	Tukang Batu	L.02	OH	0.1350	Rp 150,000	Rp 20,250
	Kepala Tukang Batu	L.03	OH	0.0135	Rp 165,000	Rp 2,228
	Mandor Batu	L.10	OH	0.0040	Rp 175,000	Rp 700
	JUMLAH HARGA TENAGA KERJA					Rp 30,873
B	BAHAN					
	PVC Kelas AW dia. 75- 3"	M.110	M	1.2000	Rp 55,875	Rp 67,050
	Perlengkapan Pipa PVC Kleas AW dia 75 (12.5%)	M.111	0	1.0000	Rp 6,984	Rp 6,984
	JUMLAH HARGA BAHAN					Rp 74,034
C	PERALATAN					
	JUMLAH HARGA ALAT					
D	Jumlah (A+B+C)					Rp 104,907
E	Overhead & Profit (15% × D)					Rp 15,736
F	Harga Satuan Pekerjaan (D+E)					Rp 120,643

Pemasangan 1 m' Power Cables NYM 4 x 4 mm						
No	Uraian	Kode	Satuan	Koefisien	Harga Satuan	Jumlah Harga
A	TENAGA KERJA					
	Pekerja	L.01	OH	0.0200	Rp 95,000	Rp 1,900
	Tukang Listrik	L.14	OH	0.1400	Rp 150,000	Rp 21,000
	Kepala tukang Listrik	L.15	OH	0.0100	Rp 165,000	Rp 1,650
	Mandor Listrik	L.16	OH	0.0100	Rp 175,000	Rp 1,750
	JUMLAH HARGA TENAGA KERJA					Rp 26,300
B	BAHAN					
	power Cables NYM 4 x 4 mm	M.112	M	1.2000	Rp 17,700	Rp 21,240
	Materil Bantu Kabel NYM 4x4(12.5%)	M.113	0	1.0000	Rp 2,213	Rp 2,213
	JUMLAH HARGA BAHAN					Rp 23,453
C	PERALATAN					
	JUMLAH HARGA ALAT					
D	Jumlah (A+B+C)					Rp 49,753
E	Overhead & Profit (15% × D)					Rp 7,463
F	Harga Satuan Pekerjaan (D+E)					Rp 57,215

NYA 3 x 2,5 mm² + PVC Conduit dia.20 untuk Lampu dan stop kontak						
No	Uraian	Kode	Satuan	Koefisien	Harga Satuan	Jumlah Harga
A	TENAGA KERJA					
	Pekerja	L.01	OH	0.0200	Rp 95,000	Rp 1,900
	Tukang Listrik	L.14	OH	0.1400	Rp 150,000	Rp 21,000
	Kepala tukang Listrik	L.15	OH	0.0100	Rp 165,000	Rp 1,650
	Mandor Listrik	L.16	OH	0.0100	Rp 175,000	Rp 1,750
	JUMLAH HARGA TENAGA KERJA					Rp 26,300
B	BAHAN					
	NYA 3 x 2.5 mm ²	M.114	M	1.2000	Rp 8,340	Rp 10,008
	PVC Conduit dia.20	M.115	M	1.0000	Rp 6,500	Rp 6,500
	JUMLAH HARGA BAHAN					Rp 16,508
C	PERALATAN					

No	Uraian	Kode	Satuan	Koefisien	Harga Satuan	Jumlah Harga
	JUMLAH HARGA ALAT					
D	Jumlah (A+B+C)					Rp 42,808
E	Overhead & Profit (15% × D)					Rp 6,421
F	Harga Satuan Pekerjaan (D+E)					Rp 49,229

Saklar 1 gang						
No	Uraian	Kode	Satuan	Koefisien	Harga Satuan	Jumlah Harga
A	TENAGA KERJA					
	Pekerja	L.01	OH	0.0400	Rp 95,000	Rp 3,800
	Tukang Listrik	L.14	OH	0.1400	Rp 150,000	Rp 21,000
	Kepala tukang Listrik	L.15	OH	0.0100	Rp 165,000	Rp 1,650
	Mandor Listrik	L.16	OH	0.0100	Rp 175,000	Rp 1,750
	JUMLAH HARGA TENAGA KERJA					Rp 28,200
B	BAHAN					
	Saklar 1 Gang	M.116	Buah	1.0000	Rp 10,500	Rp 10,500
	JUMLAH HARGA BAHAN					Rp 10,500
C	PERALATAN					
	JUMLAH HARGA ALAT					
D	Jumlah (A+B+C)					Rp 38,700
E	Overhead & Profit (15% × D)					Rp 5,805
F	Harga Satuan Pekerjaan (D+E)					Rp 44,505

Saklar 2 gang						
No	Uraian	Kode	Satuan	Koefisien	Harga Satuan	Jumlah Harga
A	TENAGA KERJA					
	Pekerja	L.01	OH	0.0400	Rp 95,000	Rp 3,800
	Tukang Listrik	L.14	OH	0.1400	Rp 150,000	Rp 21,000
	Kepala tukang Listrik	L.15	OH	0.0100	Rp 165,000	Rp 1,650
	Mandor Listrik	L.16	OH	0.0100	Rp 175,000	Rp 1,750
	JUMLAH HARGA TENAGA KERJA					Rp 28,200
B	BAHAN					
	Saklar 2 Gang	M.117	Buah	1.0000	Rp 35,000	Rp 35,000
	JUMLAH HARGA BAHAN					Rp 35,000
C	PERALATAN					
	JUMLAH HARGA ALAT					
D	Jumlah (A+B+C)					Rp 63,200
E	Overhead & Profit (15% × D)					Rp 9,480
F	Harga Satuan Pekerjaan (D+E)					Rp 72,680

Pasangan Roof Drain						
No	Uraian	Kode	Satuan	Koefisien	Harga Satuan	Jumlah Harga
A	TENAGA KERJA					
	Pekerja	L.01	OH	0.010	Rp 95,000	Rp 950
	Tukang Kayu	L.07	OH	0.100	Rp 150,000	Rp 15,000

No	Uraian	Kode	Satuan	Koefisien	Harga Satuan	Jumlah Harga
	Kepala Tukang Kayu	L.06	OH	0.010	Rp 165,000	Rp 1,650
	Mandor Kayu	L.11	OH	0.005	Rp 175,000	Rp 875
	JUMLAH HARGA TENAGA KERJA					Rp 18,475
B	BAHAN					
	Roof Drain	M.120	Buah	1.000	Rp 370,000	Rp 370,000
	JUMLAH HARGA BAHAN					Rp 370,000
C	PERALATAN					
	JUMLAH HARGA ALAT					
D	Jumlah (A+B+C)					Rp 388,475
E	Overhead & Profit (15% × D)					Rp 58,271
F	Harga Satuan Pekerjaan (D+E)					Rp 446,746

Pemasangan 1 pcs Lampu TL LED 2 x 14 Watt						
No	Uraian	Kode	Satuan	Koefisien	Harga Satuan	Jumlah Harga
A	TENAGA KERJA					
	Pekerja	L.01	OH	0.0400	Rp 95,000	Rp 3,800
	Tukang Listrik	L.14	OH	0.1400	Rp 150,000	Rp 21,000
	Kepala tukang Listrik	L.15	OH	0.0100	Rp 165,000	Rp 1,650
	Mandor Listrik	L.16	OH	0.0100	Rp 175,000	Rp 1,750
	JUMLAH HARGA TENAGA KERJA					Rp 28,200
B	BAHAN					
	Lampu TL LED 2 x 16 Watt	M.121	Buah	1.0000	Rp 165,000	Rp 165,000
	JUMLAH HARGA BAHAN					Rp 165,000
C	PERALATAN					
	JUMLAH HARGA ALAT					
D	Jumlah (A+B+C)					Rp 193,200
E	Overhead & Profit (15% × D)					Rp 28,980
F	Harga Satuan Pekerjaan (D+E)					Rp 222,180

Pemasangan 1 pcs Lampu TL LED 14 Watt						
No	Uraian	Kode	Satuan	Koefisien	Harga Satuan	Jumlah Harga
A	TENAGA KERJA					
	Pekerja	L.01	OH	0.0400	Rp 95,000	Rp 3,800
	Tukang Listrik	L.14	OH	0.1400	Rp 150,000	Rp 21,000
	Kepala tukang Listrik	L.15	OH	0.0100	Rp 165,000	Rp 1,650
	Mandor Listrik	L.16	OH	0.0100	Rp 175,000	Rp 1,750
	JUMLAH HARGA TENAGA KERJA					Rp 28,200
B	BAHAN					
	Lampu TL LED 14 Watt	M.122	Buah	1.0000	Rp 113,000	Rp 113,000
	JUMLAH HARGA BAHAN					Rp 113,000
C	PERALATAN					
	JUMLAH HARGA ALAT					
D	Jumlah (A+B+C)					Rp 141,200
E	Overhead & Profit (15% × D)					Rp 21,180
F	Harga Satuan Pekerjaan (D+E)					Rp 162,380

Pemasangan 1 pcs Lampu Bohlam LED 10 Watt						
No	Uraian	Kode	Satuan	Koefisien	Harga Satuan	Jumlah Harga
A	TENAGA KERJA					
	Pekerja	L.01	OH	0.0200	Rp 95,000	Rp 1,900
	Tukang Listrik	L.14	OH	0.1000	Rp 150,000	Rp 15,000
	Kepala tukang Listrik	L.15	OH	0.0100	Rp 165,000	Rp 1,650
	Mandor Listrik	L.16	OH	0.0100	Rp 175,000	Rp 1,750
	JUMLAH HARGA TENAGA KERJA					Rp 20,300
B	BAHAN					
	Lampu Bohlam LED 10 Watt	M.123	Buah	1.0000	Rp 45,500	Rp 45,500
	JUMLAH HARGA BAHAN					Rp 45,500
C	PERALATAN					
	JUMLAH HARGA ALAT					
D	Jumlah (A+B+C)					Rp 65,800
E	Overhead & Profit (15% × D)					Rp 9,870
F	Harga Satuan Pekerjaan (D+E)					Rp 75,670

Pemasangan 1 m' Electronic Cable Tray size 150x50x3000x1 (2 mm)						
No	Uraian	Kode	Satuan	Koefisien	Harga Satuan	Jumlah Harga
A	TENAGA KERJA					
	Pekerja	L.01	OH	0.0500	Rp 95,000	Rp 4,750
	Tukang Listrik	L.14	OH	0.0500	Rp 150,000	Rp 7,500
	Mandor Listrik	L.16	OH	0.0500	Rp 175,000	Rp 8,750
	JUMLAH HARGA TENAGA KERJA					Rp 21,000
B	BAHAN					
	Cable Tray size 150x50x3000x1 (2 mm)	M.125	M	1.0000	Rp 102,731	Rp 102,731
	Material Bantu Cable Tray size 150x40x3000x1 (12.5%)	M.126		1.0000	Rp 12,841	Rp 12,841
	JUMLAH HARGA BAHAN					Rp 115,573
C	PERALATAN					
	JUMLAH HARGA ALAT					
D	Jumlah (A+B+C)					Rp 136,573
E	Overhead & Profit (15% × D)					Rp 20,486
F	Harga Satuan Pekerjaan (D+E)					Rp 157,059

Stop Kontak 250v						
No	Uraian	Kode	Satuan	Koefisien	Harga Satuan	Jumlah Harga
A	TENAGA KERJA					
	Pekerja	L.01	OH	0.0400	Rp 95,000	Rp 3,800
	Tukang Listrik	L.14	OH	0.1400	Rp 150,000	Rp 21,000
	Kepala tukang Listrik	L.15	OH	0.0100	Rp 165,000	Rp 1,650
	Mandor Listrik	L.16	OH	0.0100	Rp 175,000	Rp 1,750
	JUMLAH HARGA TENAGA KERJA					Rp 28,200
B	BAHAN					
	Stop Kontak 250 watt	M.124	Buah	1.0000	Rp 30,448	Rp 30,448
	JUMLAH HARGA BAHAN					Rp 30,448
C	PERALATAN					
	JUMLAH HARGA ALAT					

No	Uraian	Kode	Satuan	Koefisien	Harga Satuan	Jumlah Harga
D	Jumlah (A+B+C)					Rp 58,648
E	Overhead & Profit (15% × D)					Rp 8,797
F	Harga Satuan Pekerjaan (D+E)					Rp 67,445

Pemasangan 1 m' Kabel Coaxial Tipe RG59 untuk CCTV						
No	Uraian	Kode	Satuan	Koefisien	Harga Satuan	Jumlah Harga
A	TENAGA KERJA					
	Pekerja	L.01	OH	0.0200	Rp 95,000	Rp 1,900
	Tukang Listrik	L.14	OH	0.1400	Rp 150,000	Rp 21,000
	Kepala tukang Listrik	L.15	OH	0.0100	Rp 165,000	Rp 1,650
	Mandor Listrik	L.16	OH	0.0100	Rp 175,000	Rp 1,750
	JUMLAH HARGA TENAGA KERJA					Rp 26,300
B	BAHAN					
	Kabel Croaxial RG59	M.127	M	1.2000	Rp 3,100	Rp 3,720
	Material Bantu Kabel Croaxial RG59(12.5%)	M.128		1.0000	Rp 388	Rp 388
	JUMLAH HARGA BAHAN					Rp 4,108
C	PERALATAN					
	JUMLAH HARGA ALAT					
D	Jumlah (A+B+C)					Rp 30,408
E	Overhead & Profit (15% × D)					Rp 4,561
F	Harga Satuan Pekerjaan (D+E)					Rp 34,969

Pemasangan 1 m' Kabel LAN untuk Wifi						
No	Uraian	Kode	Satuan	Koefisien	Harga Satuan	Jumlah Harga
A	TENAGA KERJA					
	Pekerja	L.01	OH	0.0200	Rp 95,000	Rp 1,900
	Tukang Listrik	L.14	OH	0.1400	Rp 150,000	Rp 21,000
	Kepala tukang Listrik	L.15	OH	0.0100	Rp 165,000	Rp 1,650
	Mandor Listrik	L.16	OH	0.0100	Rp 175,000	Rp 1,750
	JUMLAH HARGA TENAGA KERJA					Rp 26,300
B	BAHAN					
	Kabel Lan	M.129	M	1.2000	Rp 3,500	Rp 4,200
	Material Bantu Kabel LAN (12.5)	M.130		1.0000	Rp 438	Rp 438
	JUMLAH HARGA BAHAN					Rp 4,638
C	PERALATAN					
	JUMLAH HARGA ALAT					
D	Jumlah (A+B+C)					Rp 30,938
E	Overhead & Profit (15% × D)					Rp 4,641
F	Harga Satuan Pekerjaan (D+E)					Rp 35,578

Lampiran B.1. Gambar Struktur

**DAFTAR GAMBAR STRUKTUR
GEDUNG PENGELOLA TAMAN REKREASI SAMARINDA**

NO	KODE	NO. GAMBAR	NAMA GAMBAR	SKALA
1	STR	01	DAFTAR GAMBAR STRUKTUR	1:100
2	STR	02	LETAK CPT & SPT	1:100
3	STR	03	STRATIGRAFI TANAH	1:100
4	STR	04	PENAMAAN TITIK KOLOM	1:100
5	STR	05	DENAH PONDASI	1:100
6	STR	06	DETAIL PILE CAP P1 & P2	1:15
7	STR	07	DETAIL PILE CAP P3	1:15
8	STR	08	DENAH TITIK KOLOM	1:100
9	STR	09	DETAIL KOLOM	1:25
10	STR	10	DENAH SLOOF	1:100
11	STR	11	DENAH BALOK LANTAI 2	1:100
12	STR	12	DENAH RING BALK	1:100
13	STR	13	DETAIL BALOK	1:12
14	STR	14	DETAIL BALOK	1:12
15	STR	15	PORTAL AS 3	1:100
16	STR	16	DETAIL PORTAL AS 3 - BAGIAN 1	1:30
17	STR	17	DETAIL PORTAL AS 3 - BAGIAN 2	1:30
18	STR	18	DETAIL PORTAL AS 3 - BAGIAN 3	1:30
19	STR	19	DENAH PLAT LANTAI 2	1:100
20	STR	20	DETAIL PLAT LANTAI 2	1:30
21	STR	21	DENAH TANGGA	1:15
22	STR	22	DETAIL TANGGA	1:9
23	STR	23	DENAH ATAP	1:100
24	STR	24	RENCANA KUDA-KUDA BAJA	1:32
25	STR	25	DETAIL SAMBUNGAN KUDA-KUDA BAJA	1:5
26	STR	26	DETAIL SAMBUNGAN KUDA-KUDA BAJA	1:2,5



PROGRAM STUDI TEKNIK SIPIL
FAKULTAS TEKNIK
UNIVERSITAS ATMA JAYA
YOGYAKARTA

SPESIFIKASI

ANGGOTA KELOMPOK :

SAMUEL NABABAN
(190217720)
JUAN PATRICK SOASA
(190217677)
RICHARDUS ALGA ADMAJA
(190217656)

DOSEN PENGAJAR :

Ir. HARYANTO YW., M.T.
VIENTI HADSARI, S.T., M.Eng., MECRES, Ph.D.
DIDIT GUNAWAN PRASETYO JATI, S.Kom, M.Sc.

DOSEN PEMBIMBING :

SISWADI, S.T., M.T.

GAMBAR	SKALA
--------	-------

DAFTAR GAMBAR STRUKTUR	1:100
------------------------	-------

KODE GAMBAR	NO GAMBAR	JML. GAMBAR
STR	01	26



PROGRAM STUDI TEKNIK SIPIL
 FAKULTAS TEKNIK
 UNIVERSITAS ATMA JAYA
 YOGYAKARTA

SPEKIFIKASI

ANGGOTA KELOMPOK :

SAMUEL NABABAN
 (190217720)
JUAN PATRICK SOASA
 (190217677)
RICHARDUS ALGA ADMAJA
 (190217656)

DOSEN PENGAJAR :

Ir. HARYANTO YW., M.T.
 VIENTI HADSARI, S.T., M.Eng., MECRES, Ph.D.
 DIDIT GUNAWAN PRASETYO JATI, S.Kom, M.Sc.

DOSEN PEMBIMBING :

SISWADI, S.T., M.T.

GAMBAR

SKALA

LETAK CPT & SPT

1:100

KODE GAMBAR NO GAMBAR JML. GAMBAR

STR

02

26

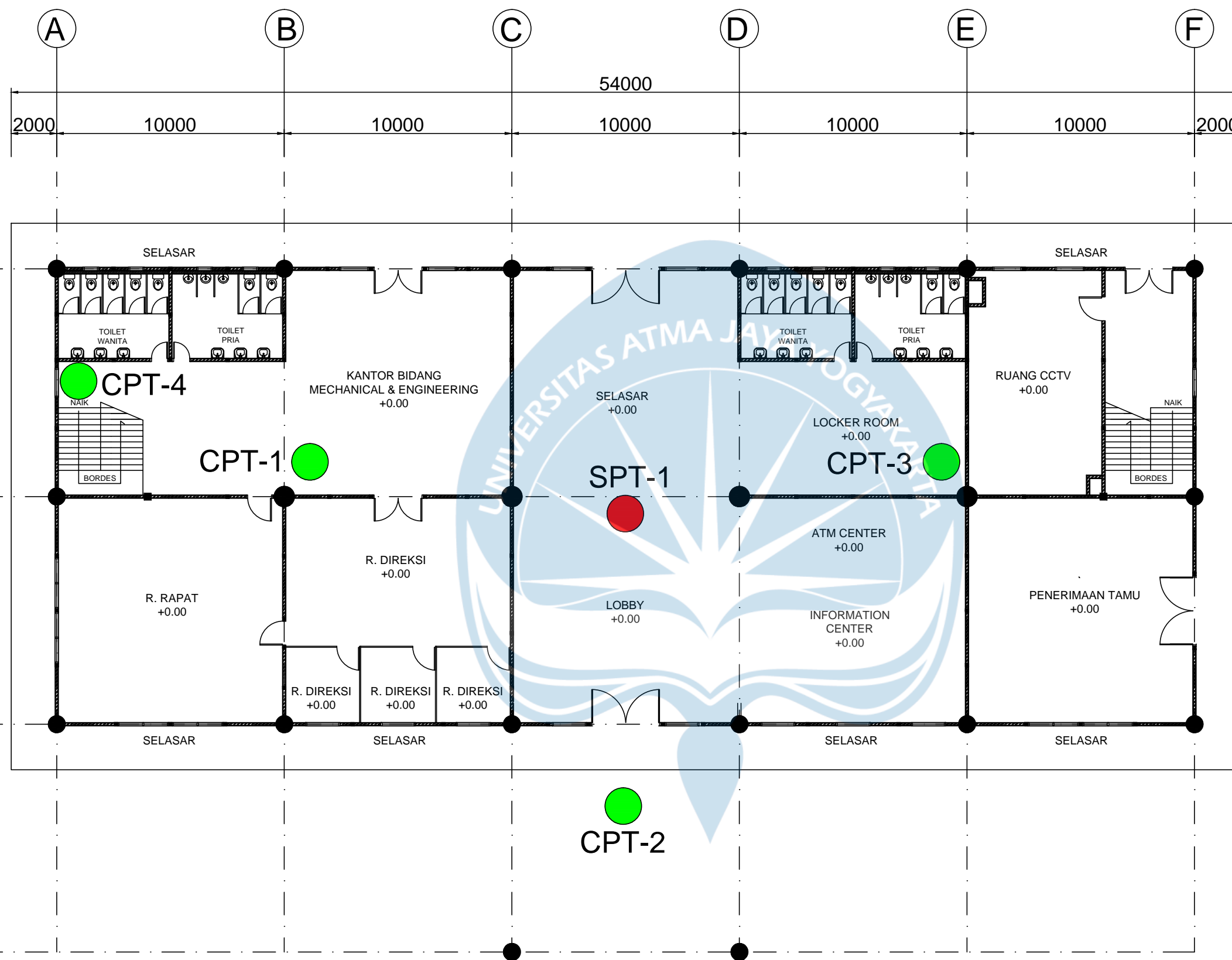

LETAK CPT & SPT
 1:100



PROGRAM STUDI TEKNIK SIPIL
 FAKULTAS TEKNIK
 UNIVERSITAS ATMA JAYA
 YOGYAKARTA

SPESIFIKASI

ANGGOTA KELOMPOK :
 SAMUEL NABABAN
 (190217720)
 JUAN PATRICK SOASA
 (190217677)
 RICHARDUS ALGA ADMAJA
 (190217656)

DOSEN PENGAJAR :
 Ir. HARYANTO YW., M.T.
 VIENTI HADSARI, S.T., M.Eng., MECRES, Ph.D.
 DIDIT GUNAWAN PRASETYO JATI, S.Kom, M.Sc.

DOSEN PEMBIMBING :
 SISWADI, S.T., M.T.

CPT-1		CPT-2		CPT-3	
0,2 m - 0,8 m	Lempung berpasir dan berlumpur	0,2 m - 0,6 m	Lempung berpasir dan berlumpur	0,2 m - 0,8 m	Lempung berpasir dan berlumpur
1,0 m - 1,6 m	Pasir	1,0 m - 1,6 m	Pasir	1,0 m - 1,6 m	Pasir
1,8 m - 8,4 m	Lempung berpasir dan berlumpur	1,8 m - 7,4 m	Lempung berpasir dan berlumpur	1,8 m - 5,2 m	Lempung berpasir dan berlumpur
8,6 m - 11 m	Pasir	7,6 m - 9,2 m	Pasir	5,4 m - 9,6 m	Pasir
11,2 m - 15,6 m	Kerikil	9,4 m - 15,6 m	Kerikil	9,8 m - 10 m	Kerikil
				10,2 m - 10,6 m	Pasir
				10,8 m - 15,6 m	Kerikil

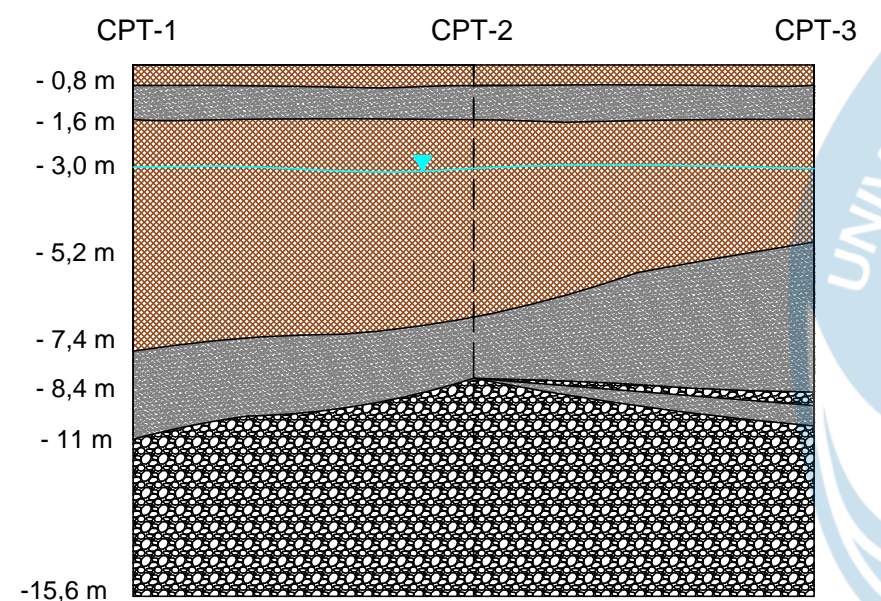

STRATIGRAFI TANAH 2 DIMENSI
 1:100

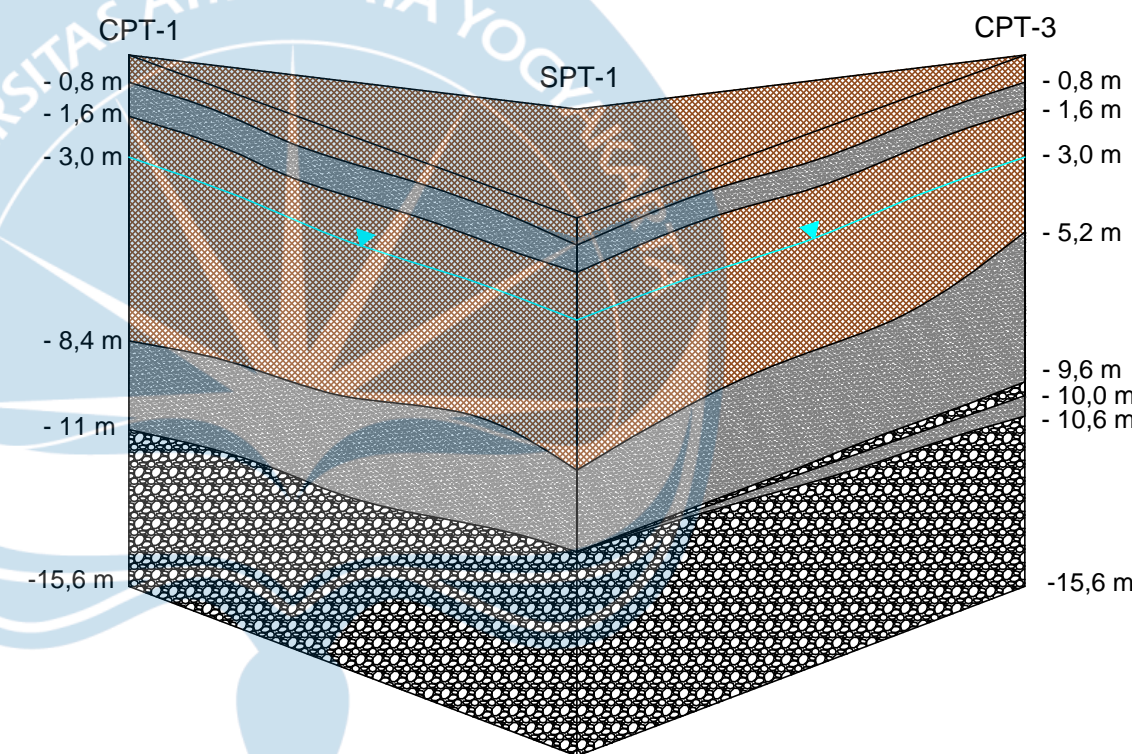

STRATIGRAFI TANAH 3 DIMENSI
 1:100

LEGENDA

- LEMPUNG BERPASIR DAN BERLUMPUR
- PASIR
- KERIKIL (GRAVELS)
- MUKA AIR TANAH

GAMBAR	SKALA	
STRATIGRAFI TANAH	1:100	
KODE GAMBAR	NO GAMBAR	JML. GAMBAR
STR	03	26



PROGRAM STUDI TEKNIK SIPIL
 FAKULTAS TEKNIK
 UNIVERSITAS ATMA JAYA
 YOGYAKARTA

SPESIFIKASI
 BERDASARKAN PEMODELAN
 ETABS

ANGGOTA KELOMPOK :
 SAMUEL NABABAN
 (190217720)
 JUAN PATRICK SOASA
 (190217677)
 RICHARDUS ALGA ADMAJA
 (190217656)

DOSEN PENGAJAR :
 Ir. HARYANTO YW., M.T.
 VIENTI HADSARI, S.T., M.Eng., MECRES, Ph.D.
 DIDIT GUNAWAN PRASETYO JATI, S.Kom, M.Sc.

DOSEN PEMBIMBING :
 SISWADI, S.T., M.T.

GAMBAR		SKALA
PENAMAAN TITIK KOLOM		1:100
KODE GAMBAR	NO GAMBAR	JML. GAMBAR
STR	04	26

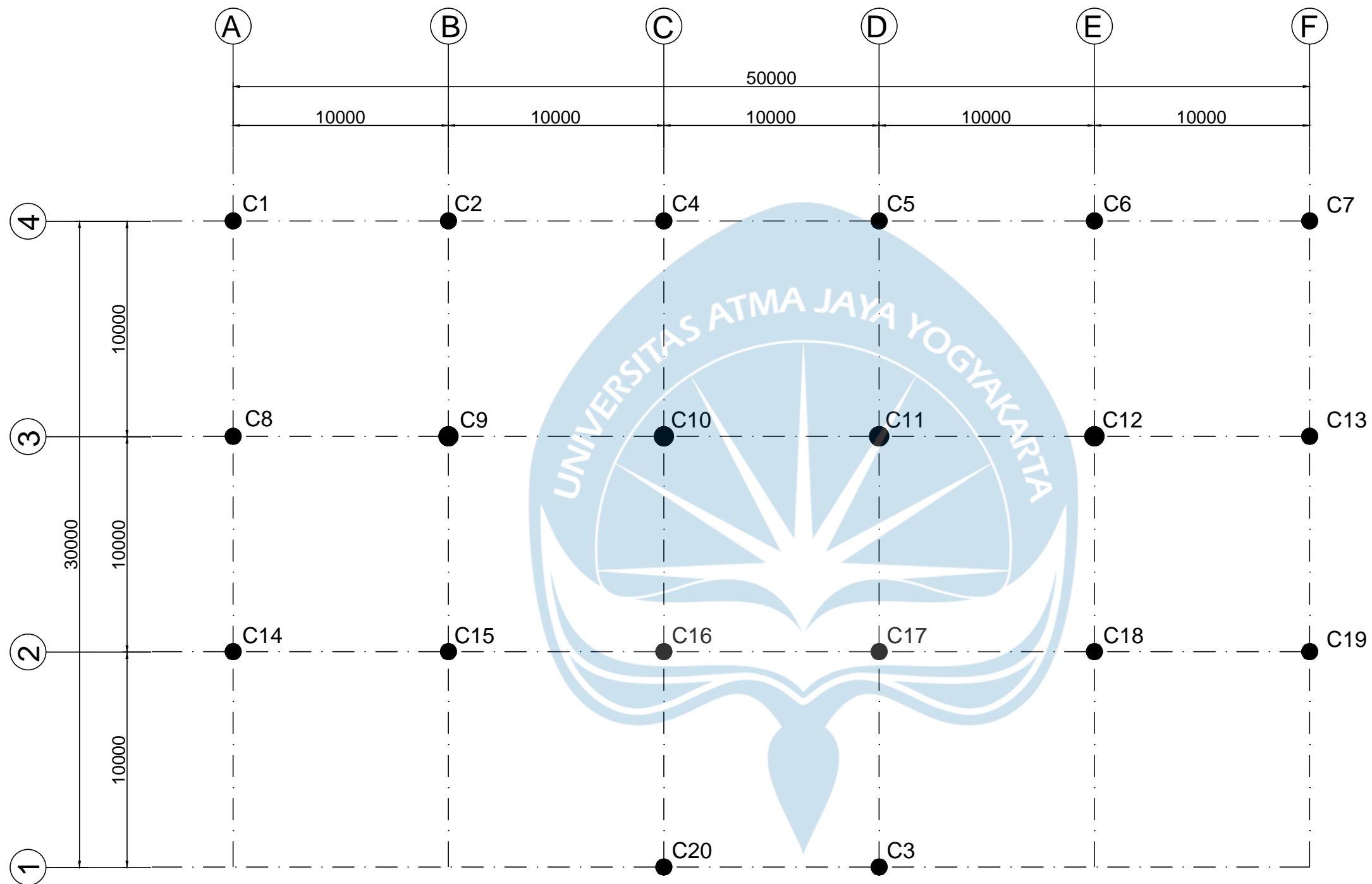

Jumlah = 20 titik kolom

PENAMAAN LETAK KOLOM
 1:100



PROGRAM STUDI TEKNIK SIPIL
 FAKULTAS TEKNIK
 UNIVERSITAS ATMA JAYA
 YOGYAKARTA

SPESIFIKASI

BETON : f_c' 25 MPa
 BAJA TULANGAN : BJTS-420

ANGGOTA KELOMPOK :

SAMUEL NABABAN
 (190217720)
 JUAN PATRICK SOASA
 (190217677)
 RICHARDUS ALGA ADMAJA
 (190217656)

DOSEN PENGAJAR :

Ir. HARYANTO YW., M.T.
 VIENTI HADSARI, S.T., M.Eng., MECRES, Ph.D.
 DIDIT GUNAWAN PRASETYO JATI, S.Kom, M.Sc.

DOSEN PEMBIMBING :

SISWADI, S.T., M.T.

GAMBAR	SKALA
--------	-------

DENAH PONDASI	1:100
---------------	-------

KODE GAMBAR	NO GAMBAR	JML. GAMBAR
STR	05	26

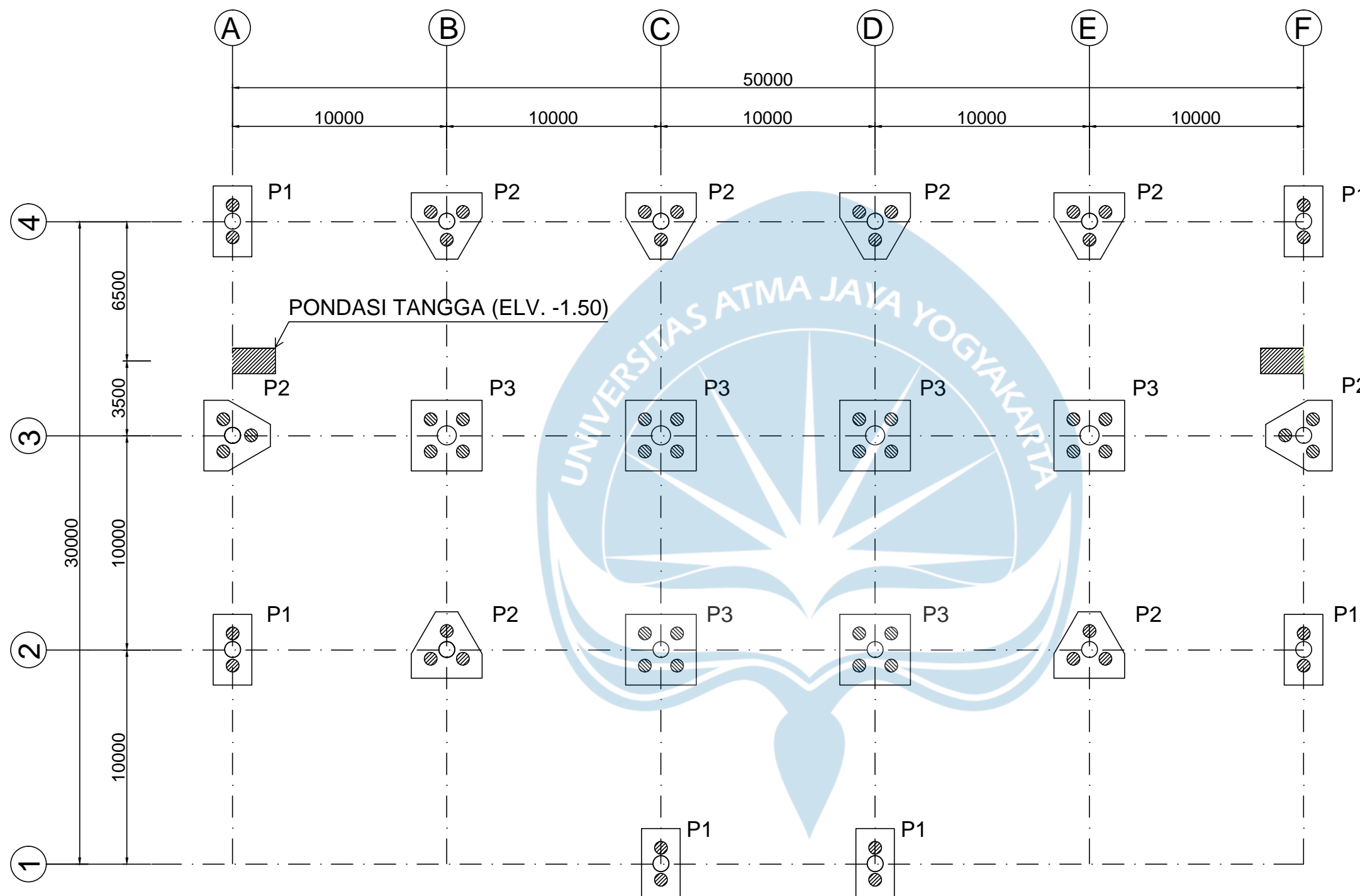

Jumlah :
 P1 = 6
 P2 = 8
 P3 = 6

DENAH PONDASI 1:100



PROGRAM STUDI TEKNIK SIPIL
 FAKULTAS TEKNIK
 UNIVERSITAS ATMA JAYA
 YOGYAKARTA

SPESIFIKASI

UJUNG TIANG PANCANG DI
 ELV -12.00
 BETON : f_c' 25 MPa
 BAJA TULANGAN : BJTS-420

ANGGOTA KELOMPOK :

SAMUEL NABABAN
 (190217720)
 JUAN PATRICK SOASA
 (190217677)
 RICHARDUS ALGA ADMAJA
 (190217656)

DOSEN PENGAJAR :

Ir. HARYANTO YW., M.T.
 VIENTI HADSARI, S.T., M.Eng., MECRES, Ph.D.
 DIDIT GUNAWAN PRASETYO JATI, S.Kom, M.Sc.

DOSEN PEMBIMBING :

SISWADI, S.T., M.T.

GAMBAR	SKALA
--------	-------

DETAIL PILE CAP P1 & P2	1:15
-------------------------	------

KODE GAMBAR	NO GAMBAR	JML. GAMBAR
-------------	-----------	-------------

STR	06	26
-----	----	----

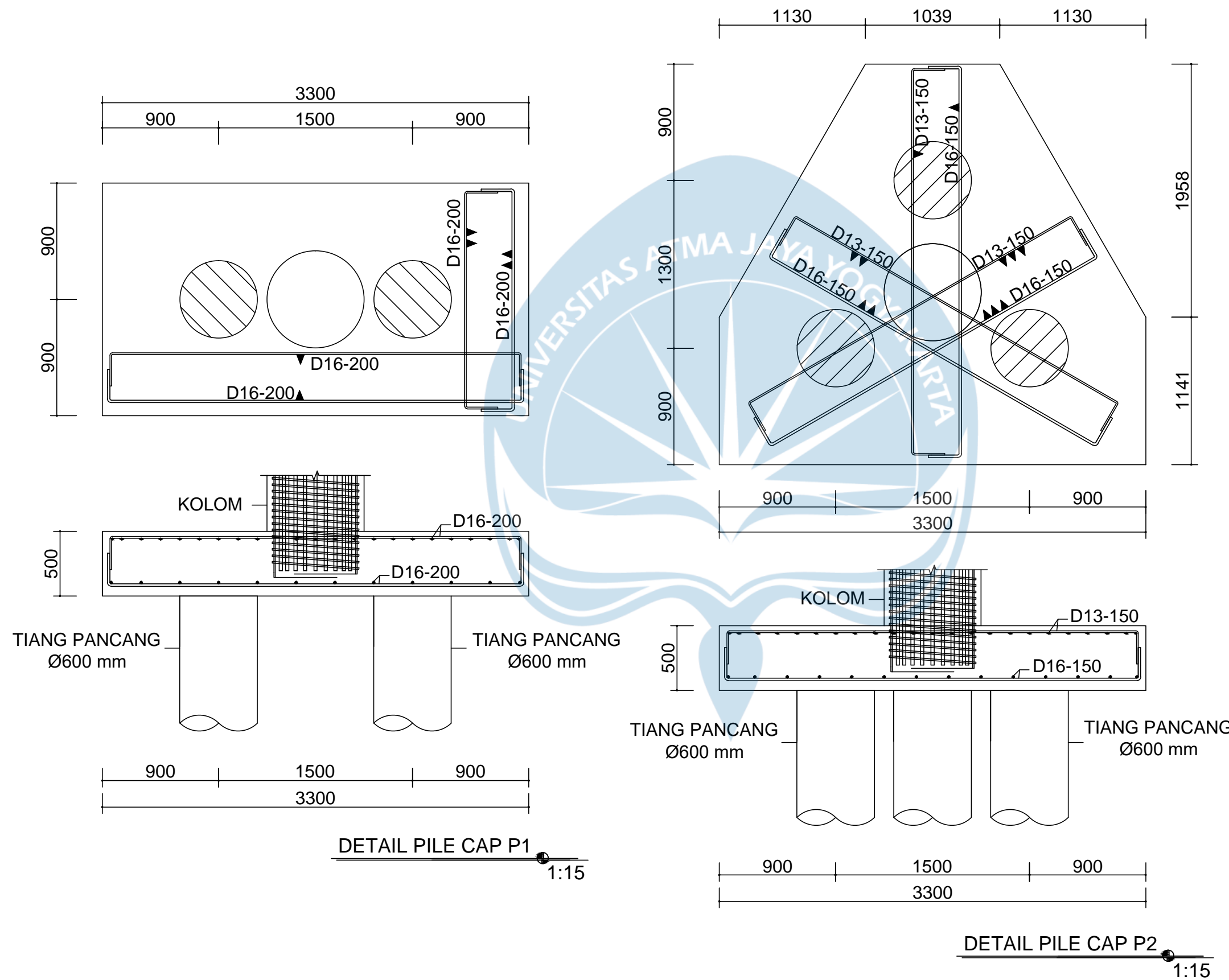



PROGRAM STUDI TEKNIK SIPIL
 FAKULTAS TEKNIK
 UNIVERSITAS ATMA JAYA
 YOGYAKARTA

SPESIFIKASI

UJUNG TIANG PANCANG DI
 ELV -12.00

BETON : f_c' 25 MPa
 BAJA TULANGAN : BJTS-420

ANGGOTA KELOMPOK :

SAMUEL NABABAN
 (190217720)
 JUAN PATRICK SOASA
 (190217677)
 RICHARDUS ALGA ADMAJA
 (190217656)

DOSEN PENGAJAR :

Ir. HARYANTO YW., M.T.
 VIENTI HADSARI, S.T., M.Eng., MECRES, Ph.D.
 DIDIT GUNAWAN PRASETYO JATI, S.Kom, M.Sc.

DOSEN PEMBIMBING :

SISWADI, S.T., M.T.

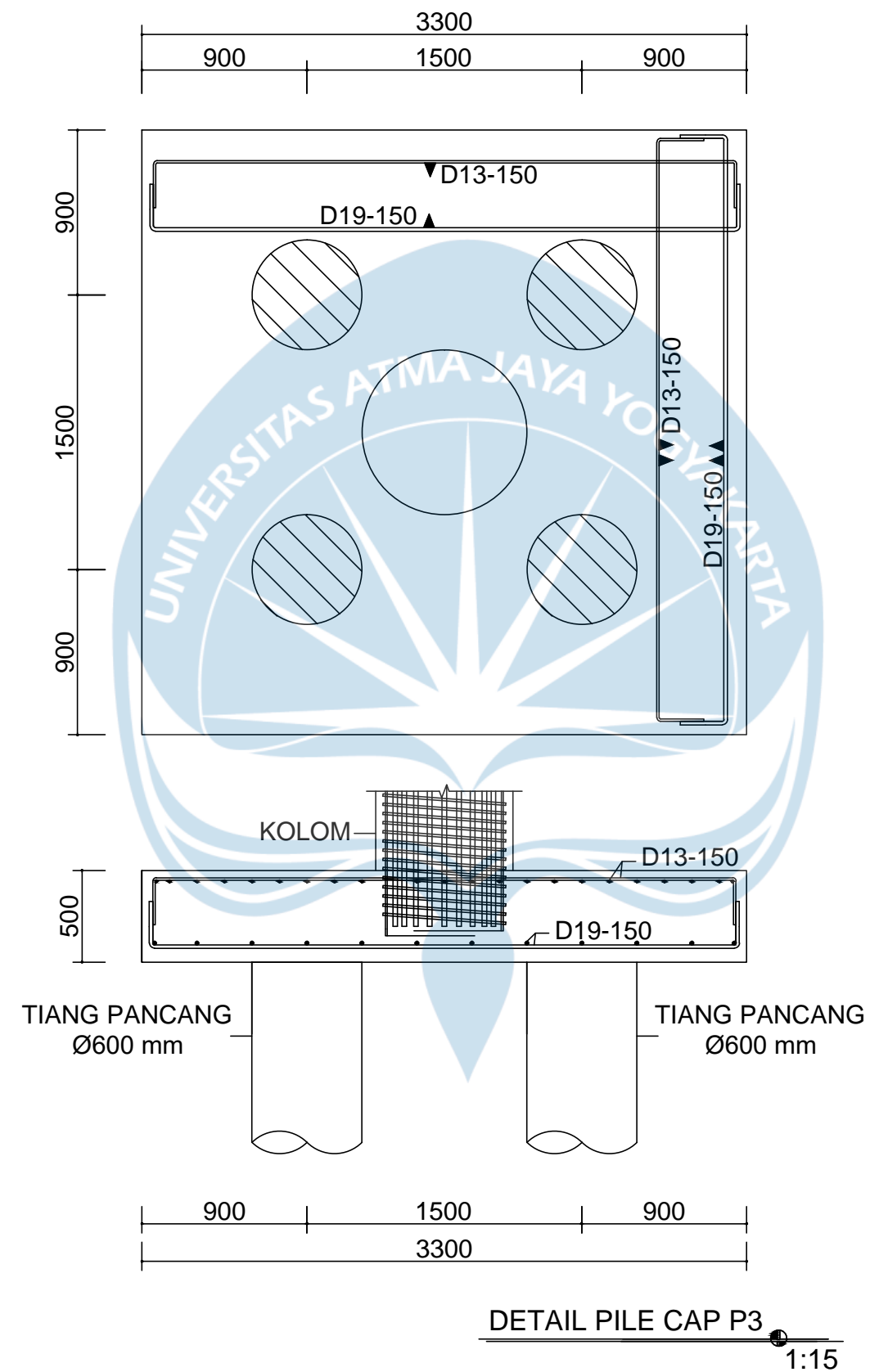

GAMBAR	SKALA
--------	-------

DETAIL PILE CAP P3	1:15
--------------------	------

KODE GAMBAR	NO GAMBAR	JML. GAMBAR
-------------	-----------	-------------

STR	07	26
-----	----	----

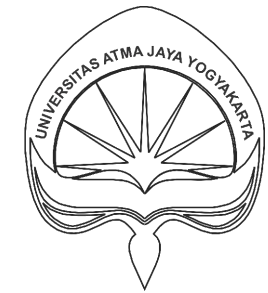

PROGRAM STUDI TEKNIK SIPIL
 FAKULTAS TEKNIK
 UNIVERSITAS ATMA JAYA
 YOGYAKARTA

SPESIFIKASI

BETON : f_c' 25 MPa
 BAJA TULANGAN : BJTS-420

ANGGOTA KELOMPOK :

SAMUEL NABABAN
 (190217720)
 JUAN PATRICK SOASA
 (190217677)
 RICHARDUS ALGA ADMAJA
 (190217656)

DOSEN PENGAJAR :

Ir. HARYANTO YW., M.T.
 VIENTI HADSARI, S.T., M.Eng., MECRES, Ph.D.
 DIDIT GUNAWAN PRASETYO JATI, S.Kom, M.Sc.

DOSEN PEMBIMBING :

SISWADI, S.T., M.T.

GAMBAR

SKALA

DENAH TITIK KOLOM

1:100

KODE GAMBAR NO GAMBAR JML. GAMBAR

STR 08 26

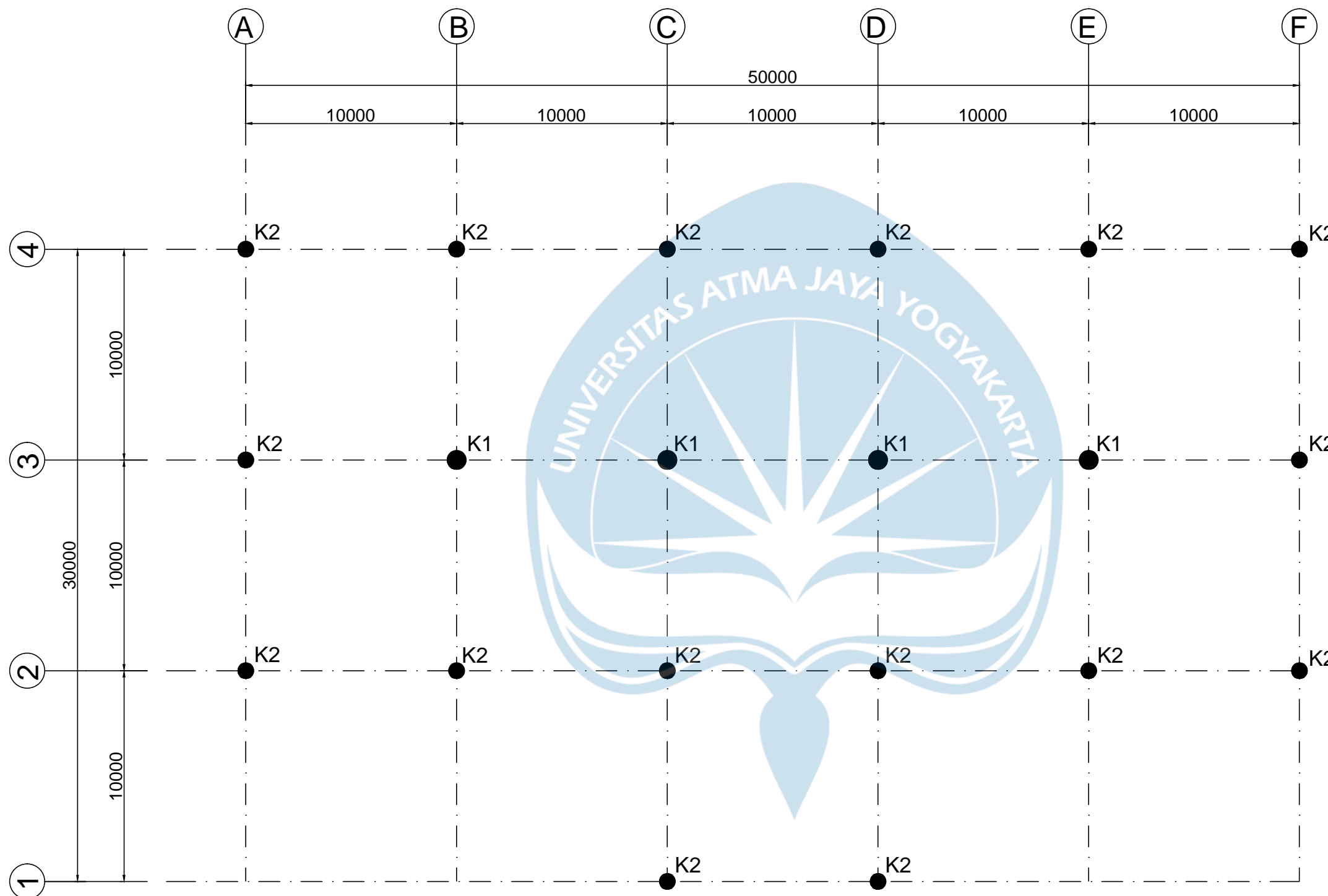

NOTASI	KETERANGAN
K1	KOLOM TIPE 1 ($\varnothing 900$)
K2	KOLOM TIPE 2 ($\varnothing 750$)

Jumlah :
 K1 = 4
 K2 = 16

DENAH TITIK KOLOM 1:100

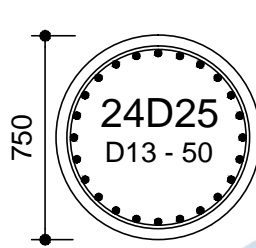
NOTASI	K1		K2	
	TUMPUAN	LAPANGAN	TUMPUAN	LAPANGAN
SENGKANG	D13 - 50	D13 - 150	D13 - 50	D13 - 50
GAMBAR				
SELIMUT BETON : 40 mm				
PENAMPANG	900		750	
TULANGAN UTAMA	36D25		24D25	

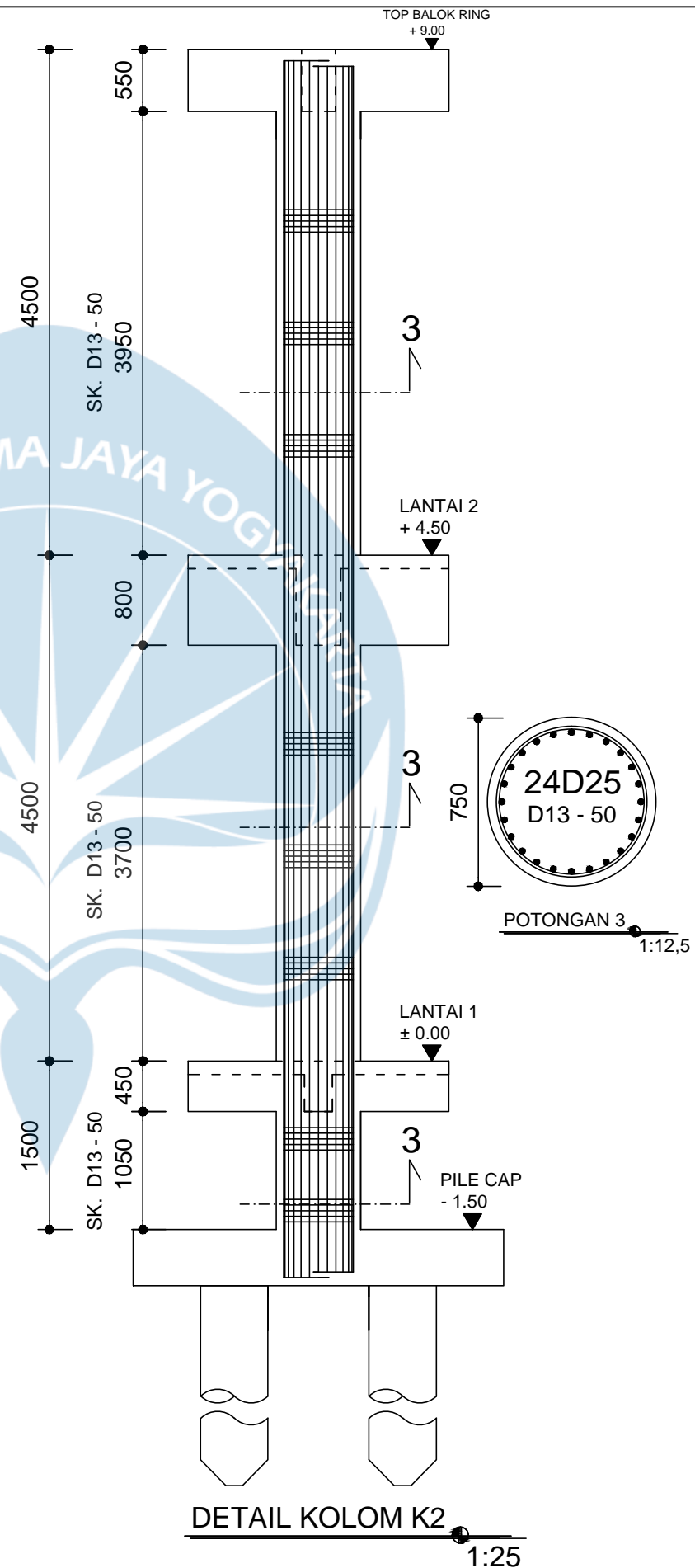
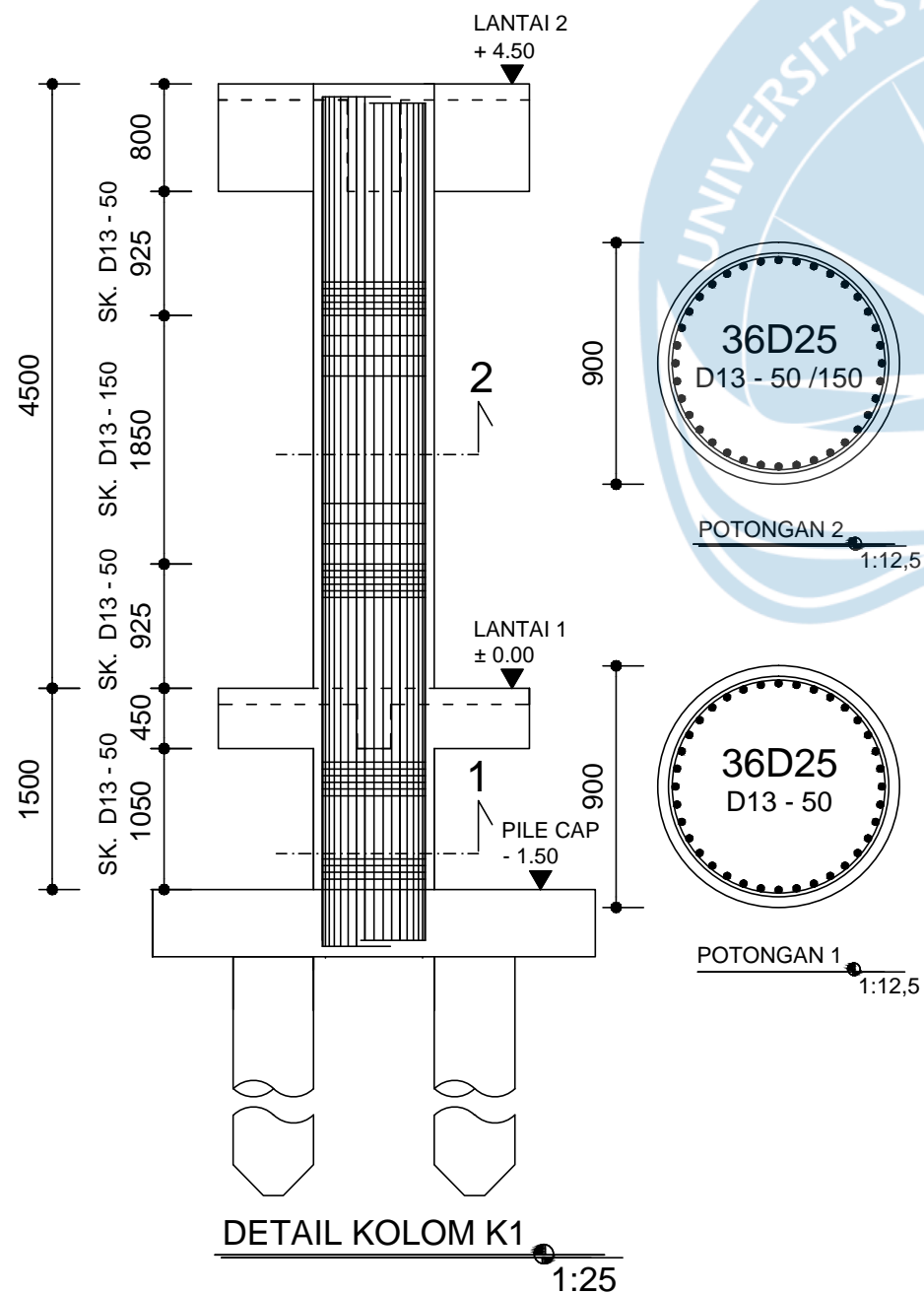

PROGRAM STUDI TEKNIK SIPIL
FAKULTAS TEKNIK
UNIVERSITAS ATMA JAYA
YOGYAKARTA

SPESIFIKASI

BETON : f_c' 25 MPa
BAJA TULANGAN : BJTS-420

ANGGOTA KELOMPOK :

SAMUEL NABABAN
(190217720)
JUAN PATRICK SOASA
(190217677)
RICHARDUS ALGA ADMAJA
(190217656)

DOSEN PENGAJAR :

Ir. HARYANTO YW., M.T.
VIENTI HADSARI, S.T., M.Eng., MECRES, Ph.D.
DIDIT GUNAWAN PRASETYO JATI, S.Kom, M.Sc.

DOSEN PEMBIMBING :

SISWADI, S.T., M.T.

GAMBAR	SKALA	
DETAIL KOLOM	1:25	
KODE GAMBAR	NO GAMBAR	JML. GAMBAR
STR	09	26



PROGRAM STUDI TEKNIK SIPIL
 FAKULTAS TEKNIK
 UNIVERSITAS ATMA JAYA
 YOGYAKARTA

SPESIFIKASI

BETON : f_c' 25 MPa
 BAJA TULANGAN : BJTS-420
 BJTS-280

ANGGOTA KELOMPOK :

SAMUEL NABABAN
 (190217720)
 JUAN PATRICK SOASA
 (190217677)
 RICHARDUS ALGA ADMAJA
 (190217656)

DOSEN PENGAJAR :

Ir. HARYANTO YW., M.T.
 VIENTI HADSARI, S.T., M.Eng., MECRES, Ph.D.
 DIDIT GUNAWAN PRASETYO JATI, S.Kom, M.Sc.

DOSEN PEMBIMBING :

SISWADI, S.T., M.T.

GAMBAR

SKALA

DENAH SLOOF

1:100

KODE GAMBAR	NO GAMBAR	JML. GAMBAR
-------------	-----------	-------------

STR	10	26
-----	----	----

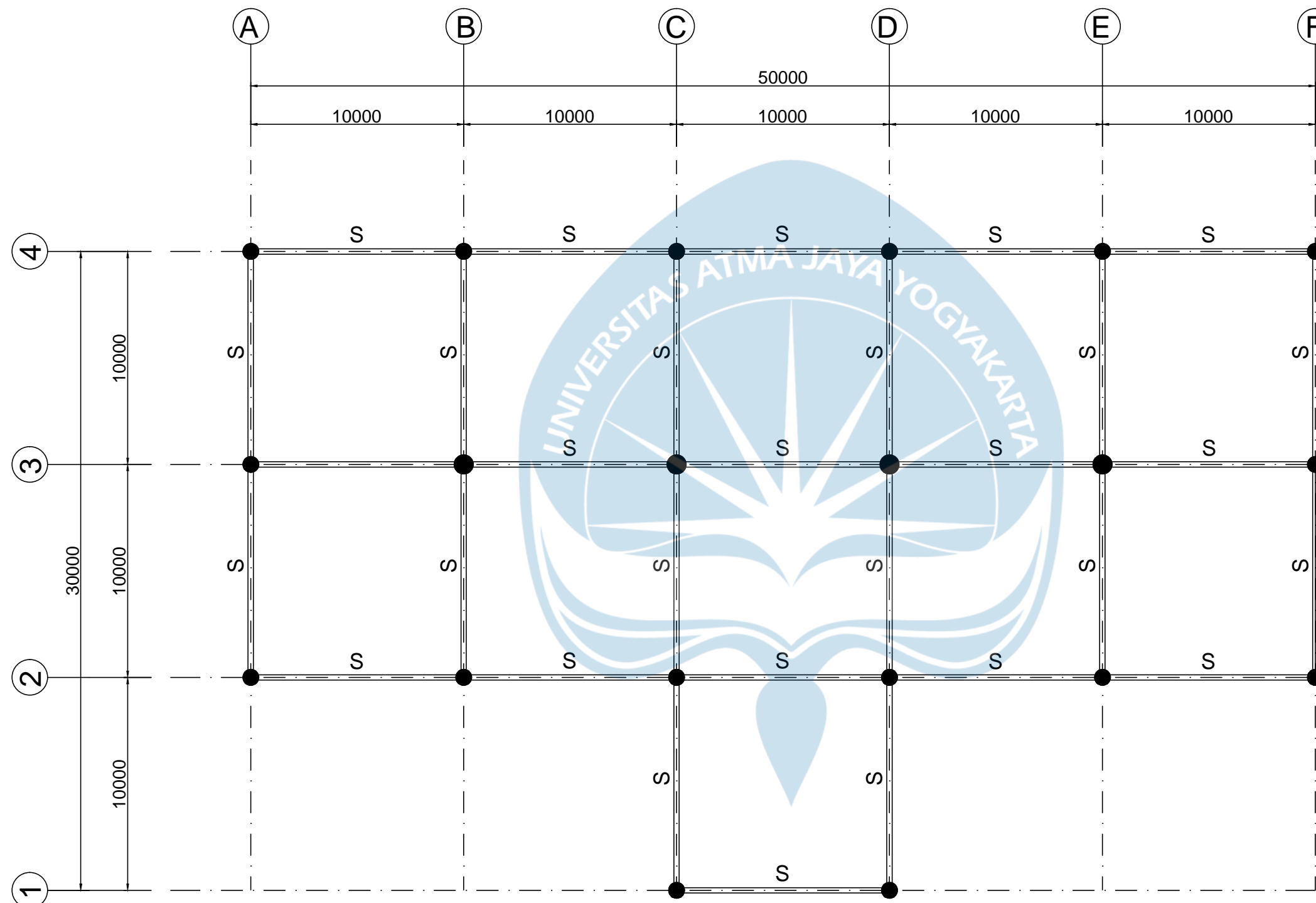

NOTASI	KETERANGAN
S	SLOOF (250 x 450)

DENAH SLOOF
 1:100



PROGRAM STUDI TEKNIK SIPIL
 FAKULTAS TEKNIK
 UNIVERSITAS ATMA JAYA
 YOGYAKARTA

SPESIFIKASI

BETON : f_c' 25 MPa
 BAJA TULANGAN : BJTS-420
 BJTS-280

ANGGOTA KELOMPOK :

SAMUEL NABABAN
 (190217720)
 JUAN PATRICK SOASA
 (190217677)
 RICHARDUS ALGA ADMAJA
 (190217656)

DOSEN PENGAJAR :

Ir. HARYANTO YW., M.T.
 VIENTI HADSARI, S.T., M.Eng., MECRES, Ph.D.
 DIDIT GUNAWAN PRASETYO JATI, S.Kom, M.Sc.

DOSEN PEMBIMBING :

SISWADI, S.T., M.T.

GAMBAR

SKALA

DENAH BALOK
 LANTAI 2

1:100

KODE GAMBAR NO GAMBAR JML. GAMBAR

STR 11 26

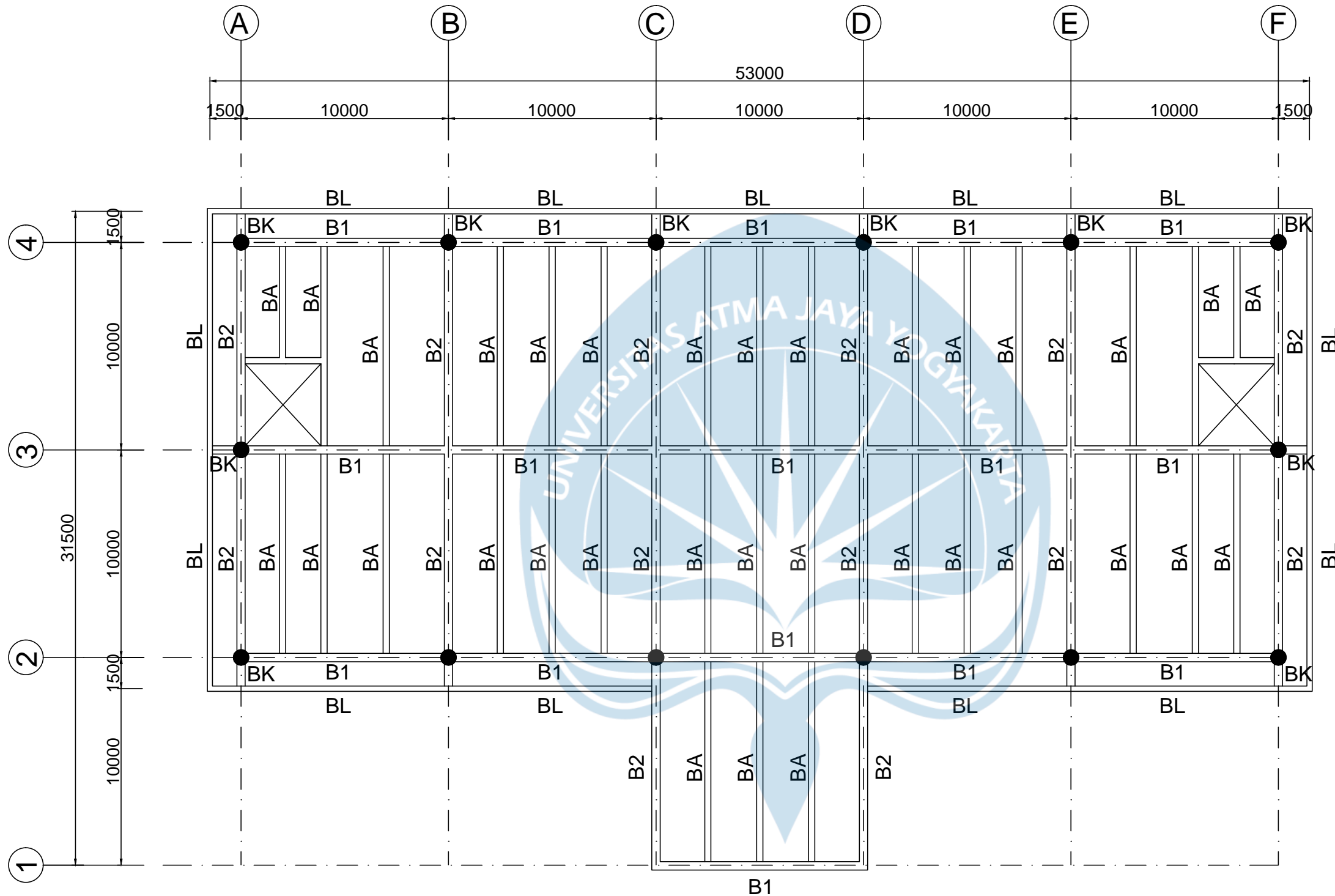

DENAH BALOK LANTAI 2
 1:100

NOTASI	KETERANGAN	NOTASI	KETERANGAN
B1	BALOK TIPE 1 (400 x 800)	BK	BALOK KANTILEVER (400 x 600)
B2	BALOK TIPE 2 (400 x 700)		
BA	BALOK ANAK (300 x 550)		
BL	BALOK LISPLANG (250 x 600)		



PROGRAM STUDI TEKNIK SIPIL
 FAKULTAS TEKNIK
 UNIVERSITAS ATMA JAYA
 YOGYAKARTA

SPESIFIKASI

BETON : f_c' 25 MPa
 BAJA TULANGAN : BJTS-420
 BJTS-280

ANGGOTA KELOMPOK :

SAMUEL NABABAN
 (190217720)
 JUAN PATRICK SOASA
 (190217677)
 RICHARDUS ALGA ADMAJA
 (190217656)

DOSEN PENGAJAR :

Ir. HARYANTO YW., M.T.
 VIENTI HADSARI, S.T., M.Eng., MECRES, Ph.D.
 DIDIT GUNAWAN PRASETYO JATI, S.Kom, M.Sc.

DOSEN PEMBIMBING :

SISWADI, S.T., M.T.

GAMBAR

SKALA

DENAH RING BALK

1:100

KODE GAMBAR NO GAMBAR JML. GAMBAR

STR

12

26

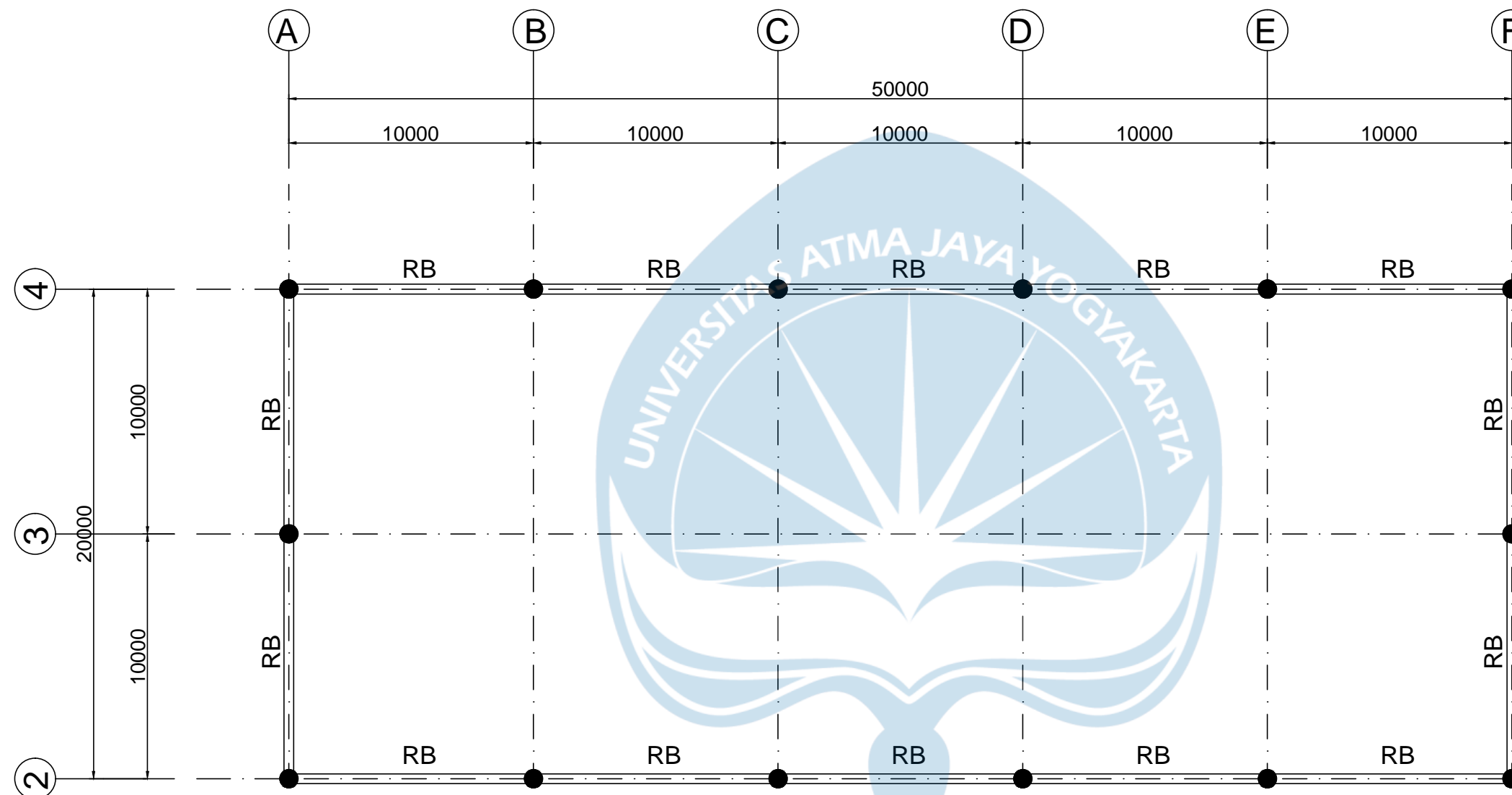

NOTASI	KETERANGAN
RB	RING BALK (300 x 550)

DENAH RING BALK
 1:100



PROGRAM STUDI TEKNIK SIPIL
FAKULTAS TEKNIK
UNIVERSITAS ATMA JAYA
YOGYAKARTA

SPESIFIKASI

BETON : $f_c' 25 \text{ MPa}$
BAJA TULANGAN : BJTS-420
BAJA TULANGAN : BJTS-280

ANGGOTA KELOMPOK :

SAMUEL NABABAN
(190217720)
JUAN PATRICK SOASA
(190217677)
RICHARDUS ALGA ADMAJA
(190217656)

DOSEN PENGAJAR :

Ir. HARYANTO YW., M.T.
VIENTI HADSARI, S.T., M.Eng., MECRES, Ph.D.
DIDIT GUNAWAN PRASETYO JATI, S.Kom, M.Sc.

DOSEN PEMBIMBING :

SISWADI, S.T., M.T.

GAMBAR

SKALA

DETAIL BALOK

1:12

KODE GAMBAR	NO GAMBAR	JML. GAMBAR
-------------	-----------	-------------

STR	13	26
-----	----	----

NOTASI	B1		B2	
	TUMPUAN	LAPANGAN	TUMPUAN	LAPANGAN
GAMBAR				
SELIMUT BETON : 40 mm				
PENAMPANG	400 x 800		400 x 700	
TULANGAN ATAS	10D25	4D25	6D25	3D25
TULANGAN BAWAH	7D25	7D25	4D25	4D25
TULANGAN SAMPING	4D13	4D13	4D13	4D13
SENGKANG	2d12 - 50	2d12 - 100	2d12 - 50	2d12 - 50
NOTASI	RB		S	
	TUMPUAN	LAPANGAN	TUMPUAN	LAPANGAN
GAMBAR				
SELIMUT BETON : 40 mm				
PENAMPANG	300 x 550		250 x 450	
TULANGAN ATAS	3D19	2D19	2D16	2D16
TULANGAN BAWAH	3D19	3D19	2D16	2D16
TULANGAN SAMPING	2D13	2D13	2D13	2D13
SENGKANG	2d8 - 100	2d8 - 100	2d8 - 50	2d8 - 50



PROGRAM STUDI TEKNIK SIPIL
FAKULTAS TEKNIK
UNIVERSITAS ATMA JAYA
YOGYAKARTA

SPESIFIKASI

BETON : $f_c' 25 \text{ MPa}$
BAJA TULANGAN : BJTS-420
BAJA TULANGAN : BJTS-280

ANGGOTA KELOMPOK :

SAMUEL NABABAN
(190217720)
JUAN PATRICK SOASA
(190217677)
RICHARDUS ALGA ADMAJA
(190217656)

DOSEN PENGAJAR :

Ir. HARYANTO YW., M.T.
VIENTI HADSARI, S.T., M.Eng., MECRES, Ph.D.
DIDIT GUNAWAN PRASETYO JATI, S.Kom, M.Sc.

DOSEN PEMBIMBING :

SISWADI, S.T., M.T.

GAMBAR	SKALA
DETAIL BALOK	1:12

KODE GAMBAR	NO GAMBAR	JML. GAMBAR
STR	14	26

NOTASI	BA		BL	
	TUMPUAN	LAPANGAN	TUMPUAN	LAPANGAN
GAMBAR				
SELIMUT BETON : 40 mm				
PENAMPANG	300 x 550		250 x 600	
TULANGAN ATAS	8D19	2D19	7D16	3D16
TULANGAN BAWAH	4D19	4D19	5D16	4D16
TULANGAN SAMPING	2D13	2D13	4D13	4D13
SENGKANG	2d8 - 100	2d8 - 200	2d8 - 250	2d8 - 250
NOTASI	BK		BB	
	TUMPUAN	LAPANGAN	TUMPUAN	LAPANGAN
GAMBAR				
SELIMUT BETON : 40 mm				
PENAMPANG	400 x 600	400 x 600	250 x 350	250 x 350
TULANGAN ATAS	3D25	3D25	2D13	3D13
TULANGAN BAWAH	2D25	2D25	2D13	3D13
TULANGAN SAMPING	2D13	2D13	-	-
SENGKANG	2d12 - 100	2d12 - 100	2P10 - 50	2P10 - 150



PROGRAM STUDI TEKNIK SIPIL
 FAKULTAS TEKNIK
 UNIVERSITAS ATMA JAYA
 YOGYAKARTA

SPEKIFIKASI

BETON : $f_c' 25 \text{ MPa}$
 BAJA TULANGAN : BJTS-420
 BJTS-280

ANGGOTA KELOMPOK :

SAMUEL NABABAN
 (190217720)
 JUAN PATRICK SOASA
 (190217677)
 RICHARDUS ALGA ADMAJA
 (190217656)

DOSEN PENGAJAR :

Ir. HARYANTO YW., M.T.
 VIENTI HADSARI, S.T., M.Eng., MECRES, Ph.D.
 DIDIT GUNAWAN PRASETYO JATI, S.Kom, M.Sc.

DOSEN PEMBIMBING :

SISWADI, S.T., M.T.

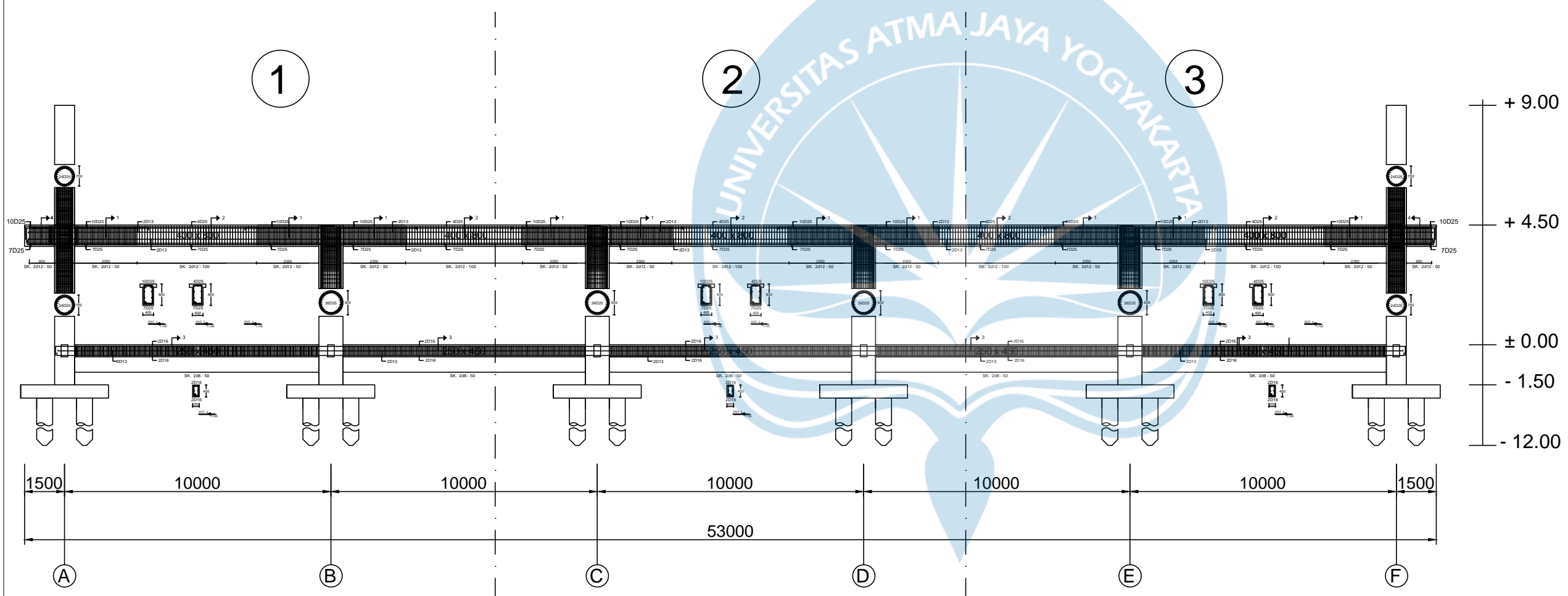

PORTAL AS - 3
 1:100

GAMBAR	SKALA	
PORTAL AS 3	1:90	
KODE GAMBAR	NO GAMBAR	JML. GAMBAR
STR	15	26



PROGRAM STUDI TEKNIK SIPIL
 FAKULTAS TEKNIK
 UNIVERSITAS ATMA JAYA
 YOGYAKARTA

SPEKIFIKASI

BETON : $f_c' 25 \text{ MPa}$
 BAJA TULANGAN : BJTS-420

ANGGOTA KELOMPOK :

SAMUEL NABABAN
 (190217720)
JUAN PATRICK SOASA
 (190217677)
RICHARDUS ALGA ADMAJA
 (190217656)

DOSEN PENGAJAR :

Ir. HARYANTO YW., M.T.
 VIENTI HADSARI, S.T., M.Eng., MECRES, Ph.D.
 DIDIT GUNAWAN PRASETYO JATI, S.Kom, M.Sc.

DOSEN PEMBIMBING :

SISWADI, S.T., M.T.

GAMBAR

SKALA

DETAIL PORTAL AS 3
 BAGIAN 1

1:30

KODE GAMBAR NO GAMBAR JML. GAMBAR

STR

16

26

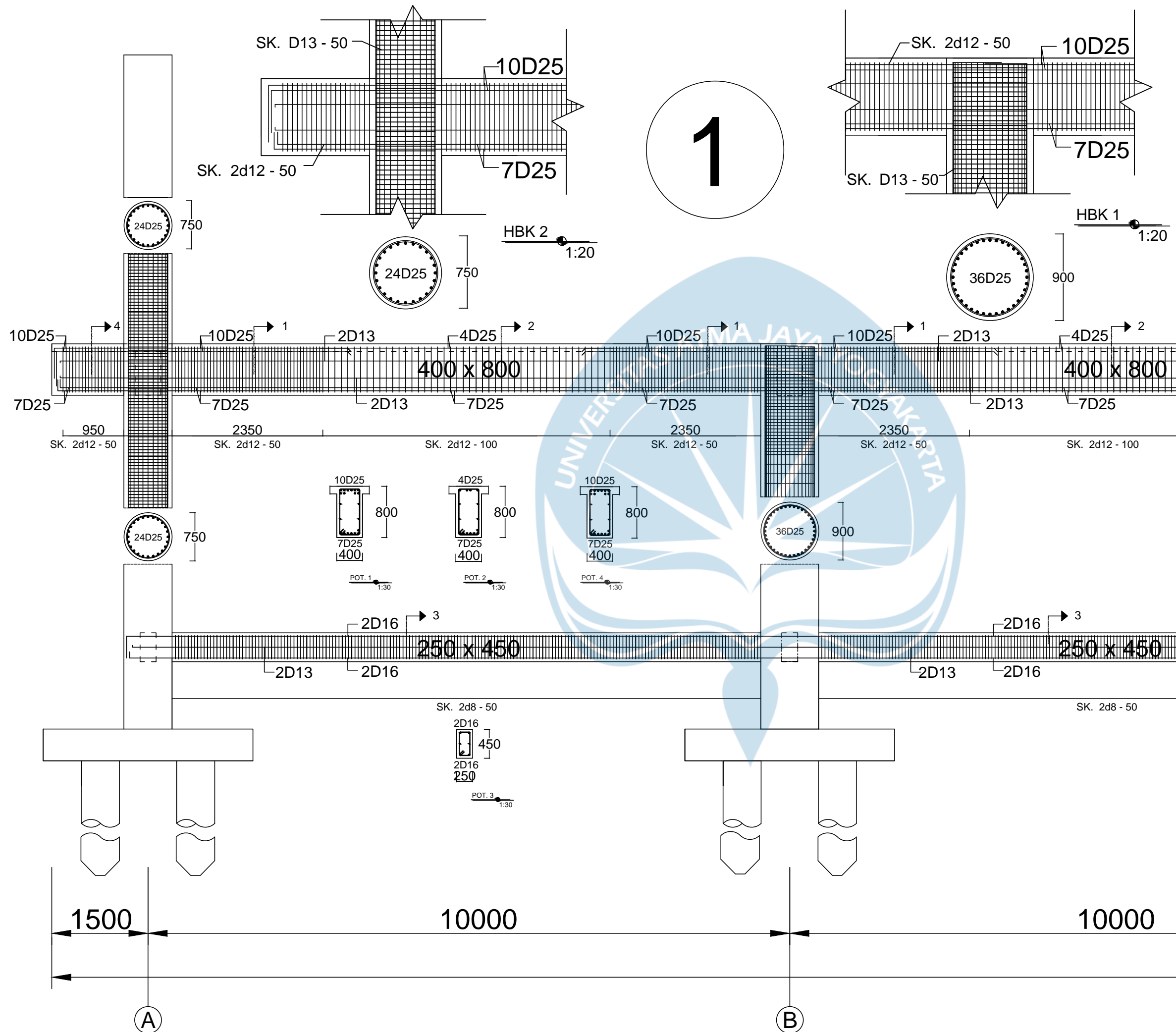

2

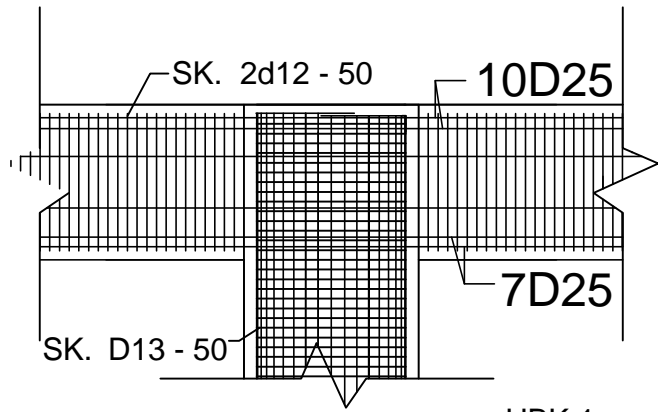

HBK 1
1:20

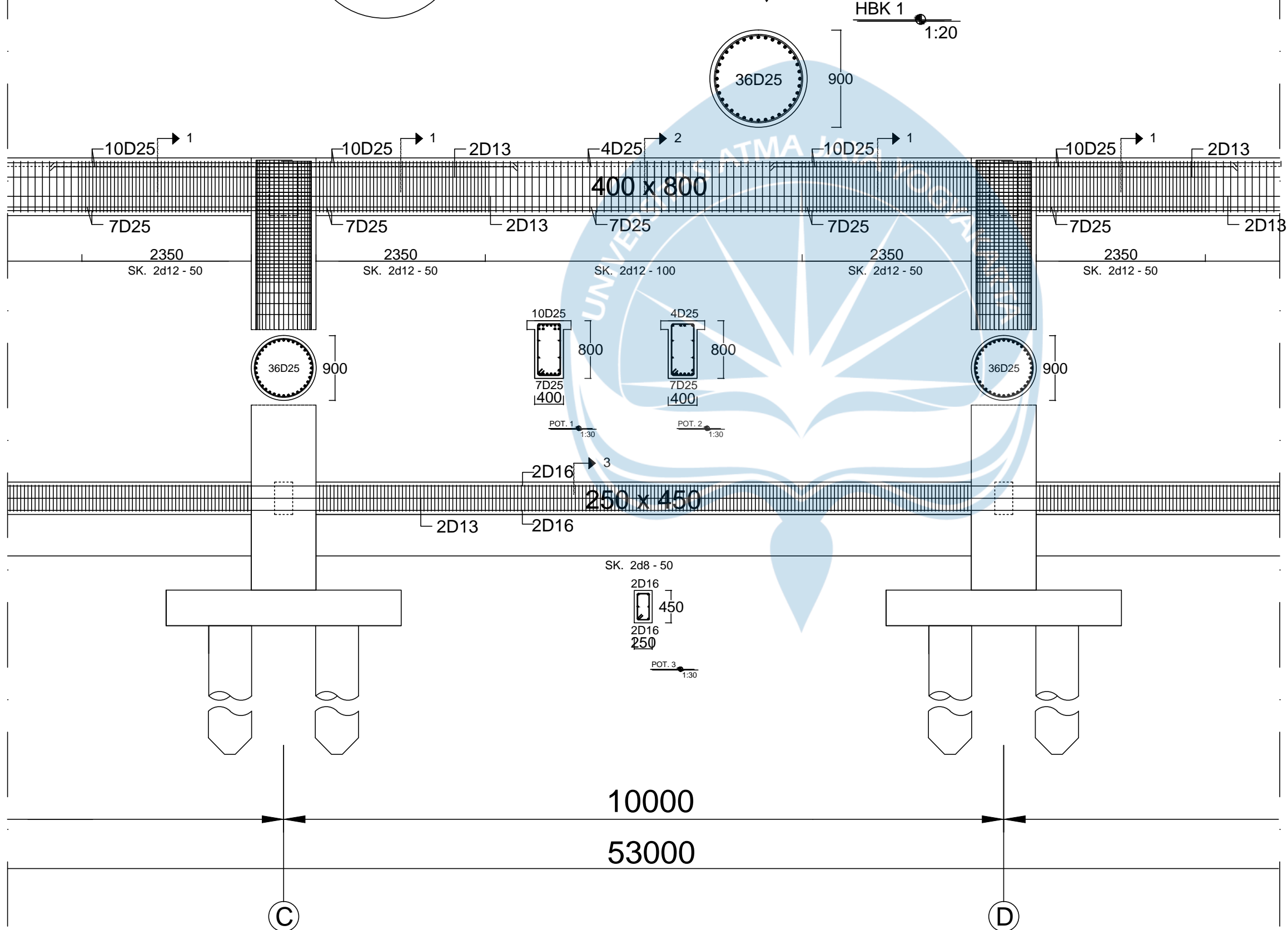

PROGRAM STUDI TEKNIK SIPIL
FAKULTAS TEKNIK
UNIVERSITAS ATMA JAYA
YOGYAKARTA

SPEKIFIKASI

BETON : $f_c' 25 \text{ MPa}$
BAJA TULANGAN : BJTS-420

ANGGOTA KELOMPOK :

SAMUEL NABABAN
(190217720)
JUAN PATRICK SOASA
(190217677)
RICHARDUS ALGA ADMAJA
(190217656)

DOSEN PENGAJAR :

Ir. HARYANTO YW., M.T.
VIENTI HADSARI, S.T., M.Eng., MECRES, Ph.D.
DIDIT GUNAWAN PRASETYO JATI, S.Kom, M.Sc.

DOSEN PEMBIMBING :

SISWADI, S.T., M.T.

GAMBAR

SKALA

DETAIL PORTAL AS 3
BAGIAN 2

1:30

KODE GAMBAR	NO GAMBAR	JML. GAMBAR
-------------	-----------	-------------

STR

17

26



PROGRAM STUDI TEKNIK SIPIL
 FAKULTAS TEKNIK
 UNIVERSITAS ATMA JAYA
 YOGYAKARTA

SPEKIFIKASI

BETON : $f_c' 25 \text{ MPa}$
 BAJA TULANGAN : BJTS-420

ANGGOTA KELOMPOK :

SAMUEL NABABAN
 (190217720)
JUAN PATRICK SOASA
 (190217677)
RICHARDUS ALGA ADMAJA
 (190217656)

DOSEN PENGAJAR :

Ir. HARYANTO YW., M.T.
 VIENTI HADSARI, S.T., M.Eng., MECRES, Ph.D.
 DIDIT GUNAWAN PRASETYO JATI, S.Kom, M.Sc.

DOSEN PEMBIMBING :

SISWADI, S.T., M.T.

GAMBAR

SKALA

DETAIL PORTAL AS 3
 BAGIAN 3

1:30

KODE GAMBAR NO GAMBAR JML. GAMBAR

STR

18

26

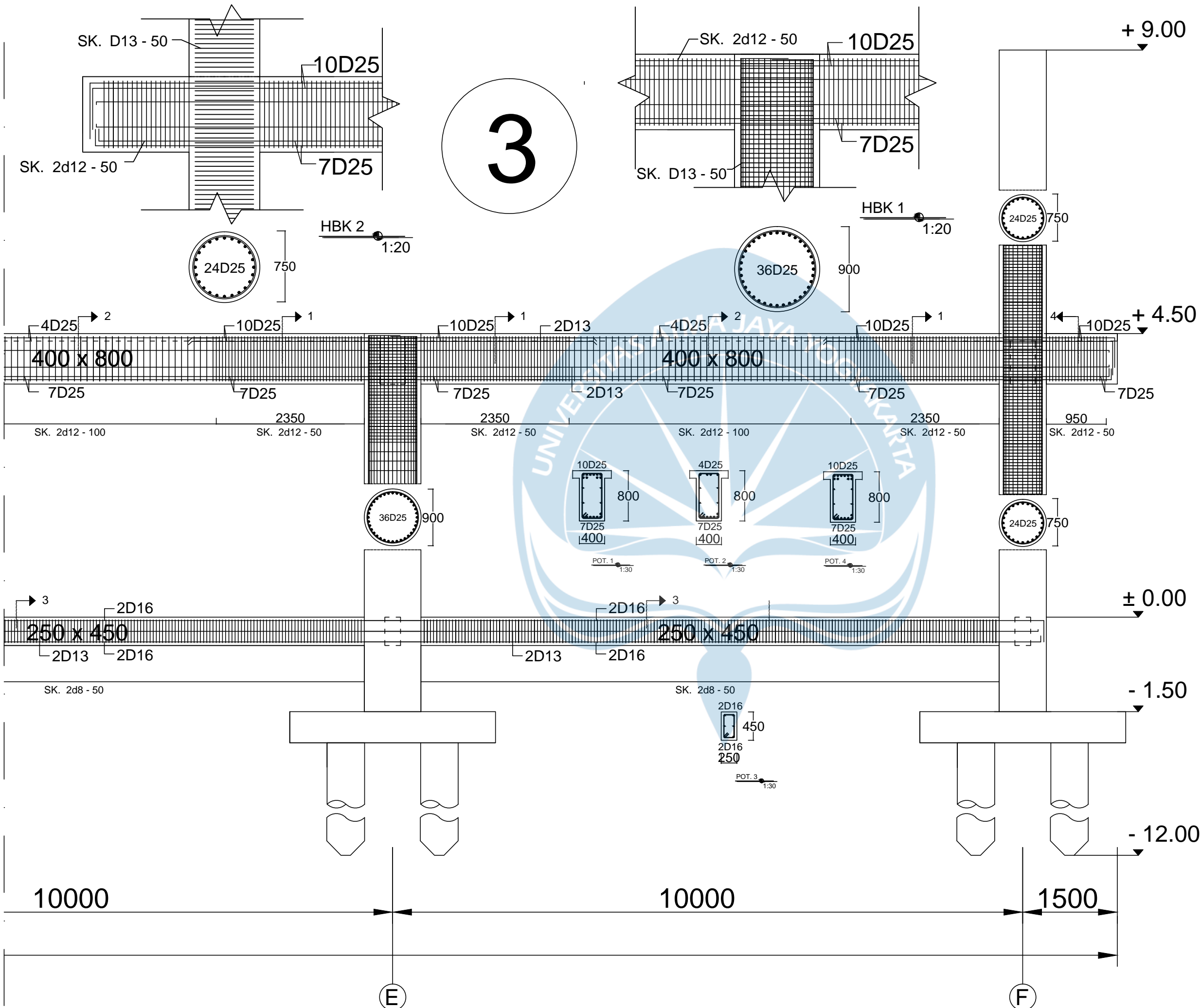



PROGRAM STUDI TEKNIK SIPIL
 FAKULTAS TEKNIK
 UNIVERSITAS ATMA JAYA
 YOGYAKARTA

SPESIFIKASI

BETON : $f_c' 25 \text{ MPa}$
 BAJA TULANGAN : BJTS-420

ANGGOTA KELOMPOK :

SAMUEL NABABAN
 (190217720)
 JUAN PATRICK SOASA
 (190217677)
 RICHARDUS ALGA ADMAJA
 (190217656)

DOSEN PENGAJAR :

Ir. HARYANTO YW., M.T.
 VIENTI HADSARI, S.T., M.Eng., MECRES, Ph.D.
 DIDIT GUNAWAN PRASETYO JATI, S.Kom, M.Sc.

DOSEN PEMBIMBING :

SISWADI, S.T., M.T.

GAMBAR

SKALA

DENAH PLAT
 LANTAI 2

1:100

KODE GAMBAR	NO GAMBAR	JML. GAMBAR
-------------	-----------	-------------

STR	19	26
-----	----	----

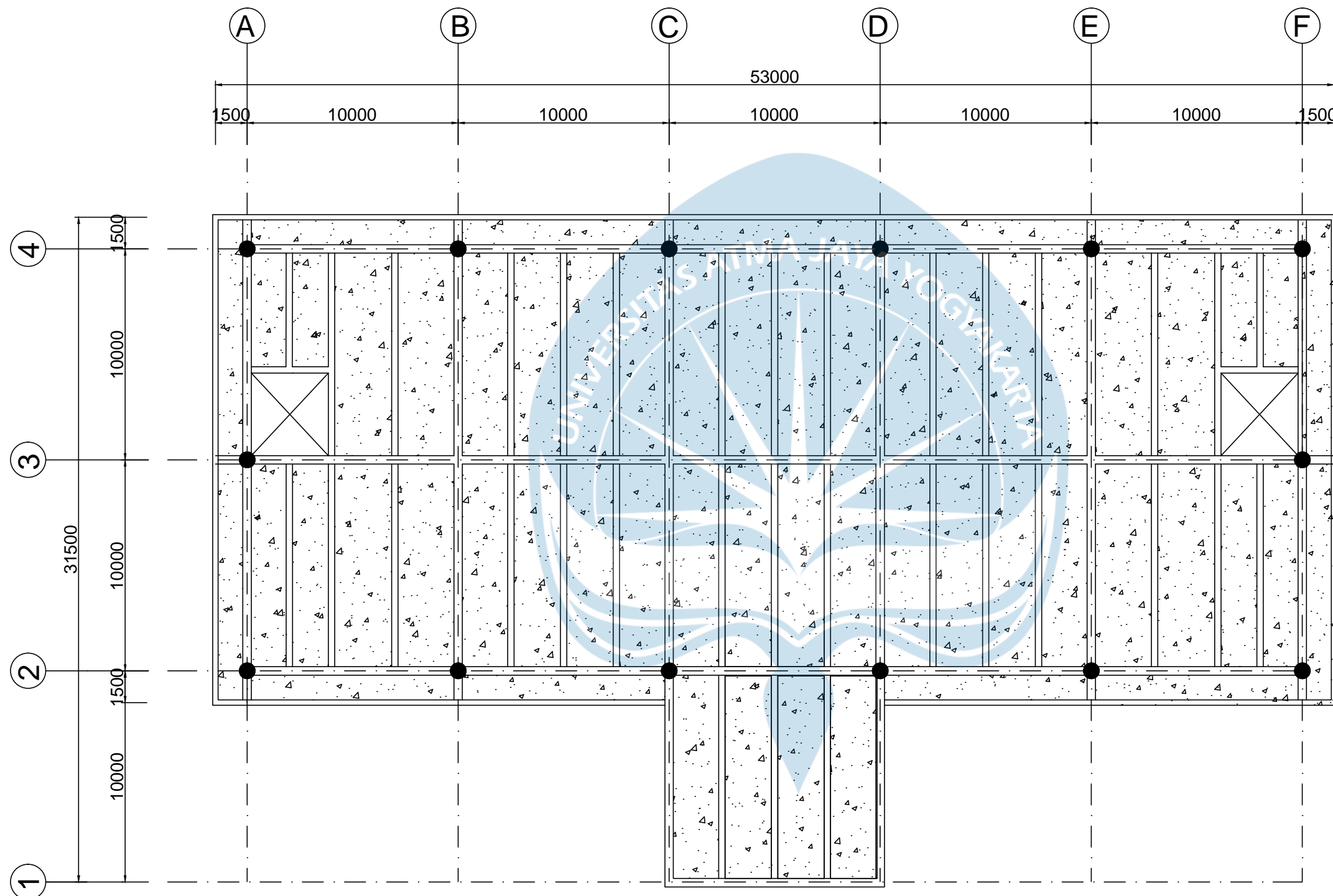

t : 120 mm (Elev + 4.50)

DENAH PLAT LANTAI 2
 1:100

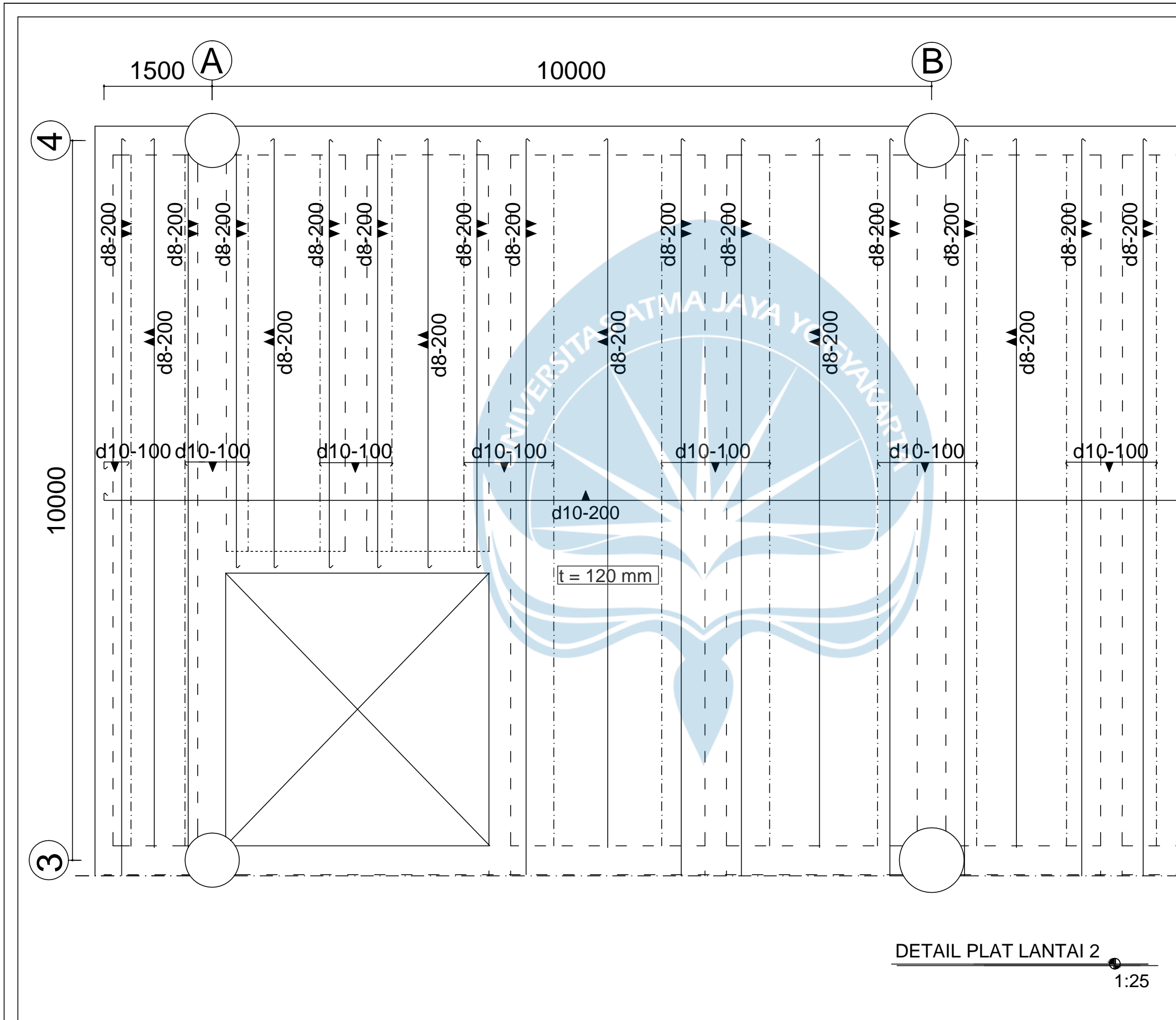

DETAIL PLAT LANTAI 2
1:25



PROGRAM STUDI TEKNIK SIPIL
FAKULTAS TEKNIK
UNIVERSITAS ATMA JAYA
YOGYAKARTA

SPESIFIKASI

BETON : f_c' 25 MPa
BAJA TULANGAN : BJTS-280

ANGGOTA KELOMPOK :

SAMUEL NABABAN
(190217720)
JUAN PATRICK SOASA
(190217677)
RICHARDUS ALGA ADMAJA
(190217656)

DOSEN PENGAJAR :

Ir. HARYANTO YW., M.T.
VIENTI HADSARI, S.T., M.Eng., MECRES, Ph.D.
DIDIT GUNAWAN PRASETYO JATI, S.Kom, M.Sc.

DOSEN PEMBIMBING :

SISWADI, S.T., M.T.

GAMBAR		SKALA
DETAIL PLAT LANTAI 2		1:30
KODE GAMBAR	NO GAMBAR	JML. GAMBAR
STR	20	26



PROGRAM STUDI TEKNIK SIPIL
 FAKULTAS TEKNIK
 UNIVERSITAS ATMA JAYA
 YOGYAKARTA

SPESIFIKASI

BETON : fc' 25 MPa
 BAJA TULANGAN : BJTS-420
 BJTP-280

ANGGOTA KELOMPOK :

SAMUEL NABABAN
 (190217720)
 JUAN PATRICK SOASA
 (190217677)
 RICHARDUS ALGA ADMAJA
 (190217656)

DOSEN PENGAJAR :

Ir. HARYANTO YW., M.T.
 VIENTI HADSARI, S.T., M.Eng., MECRES, Ph.D.
 DIDIT GUNAWAN PRASETYO JATI, S.Kom, M.Sc.

DOSEN PEMBIMBING :

SISWADI, S.T., M.T.

GAMBAR	SKALA
--------	-------

DENAH TANGGA	1:15
--------------	------

KODE GAMBAR	NO GAMBAR	JML. GAMBAR
STR	21	26

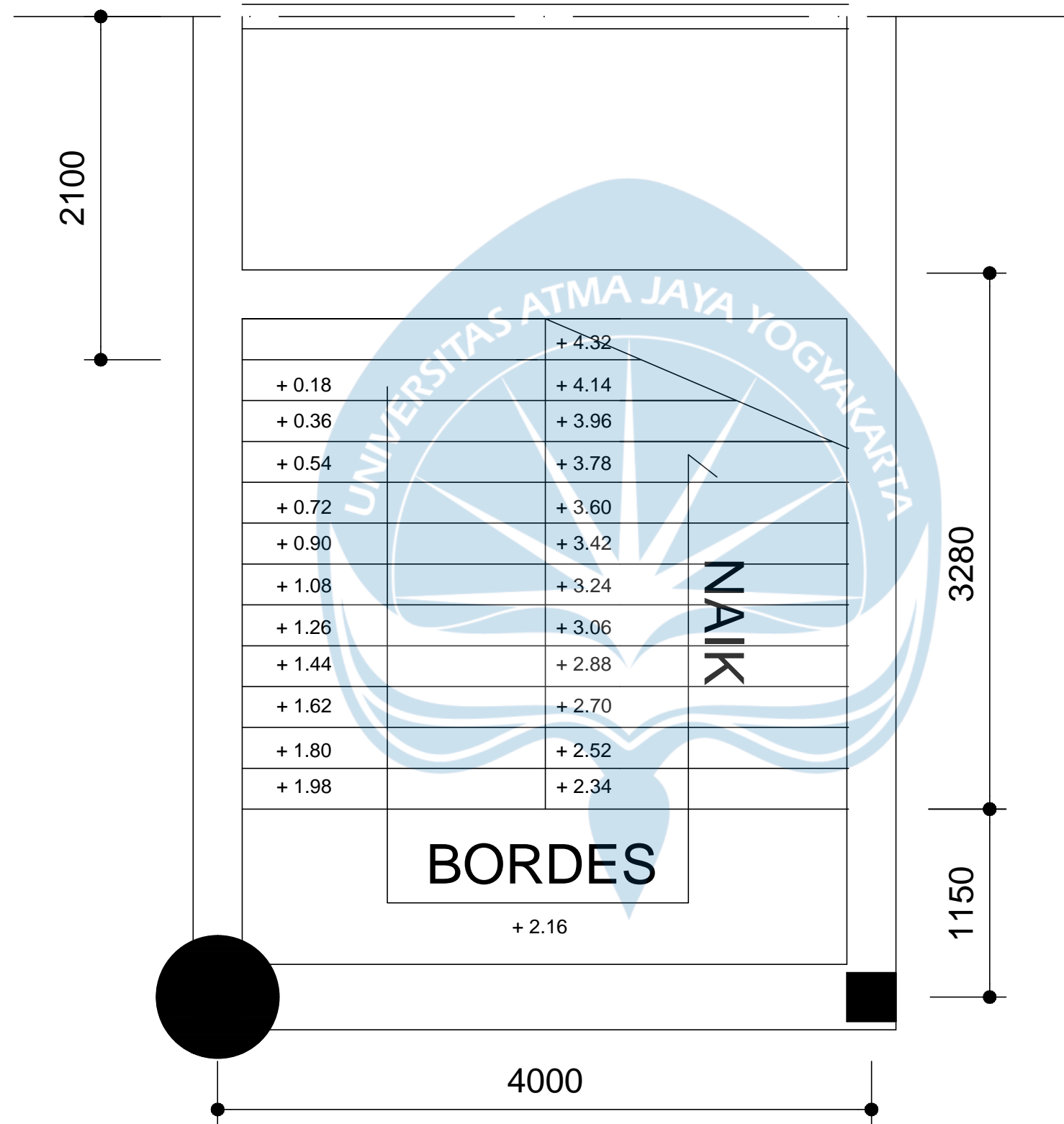

DENAH TANGGA
 1:15



PROGRAM STUDI TEKNIK SIPIL
 FAKULTAS TEKNIK
 UNIVERSITAS ATMA JAYA
 YOGYAKARTA

SPESIFIKASI

BETON : f_c' 25 MPa
 BAJA TULANGAN : BJTS-420
 BJTP-280

ANGGOTA KELOMPOK :

SAMUEL NABABAN
 (190217720)
 JUAN PATRICK SOASA
 (190217677)
 RICHARDUS ALGA ADMAJA
 (190217656)

DOSEN PENGAJAR :

Ir. HARYANTO YW., M.T.
 VIENTI HADSARI, S.T., M.Eng., MECRES, Ph.D.
 DIDIT GUNAWAN PRASETYO JATI, S.Kom, M.Sc.

DOSEN PEMBIMBING :

SISWADI, S.T., M.T.

GAMBAR

SKALA

DETAIL TANGGA

1:9

KODE GAMBAR	NO GAMBAR	JML. GAMBAR
-------------	-----------	-------------

STR	22	26
-----	----	----

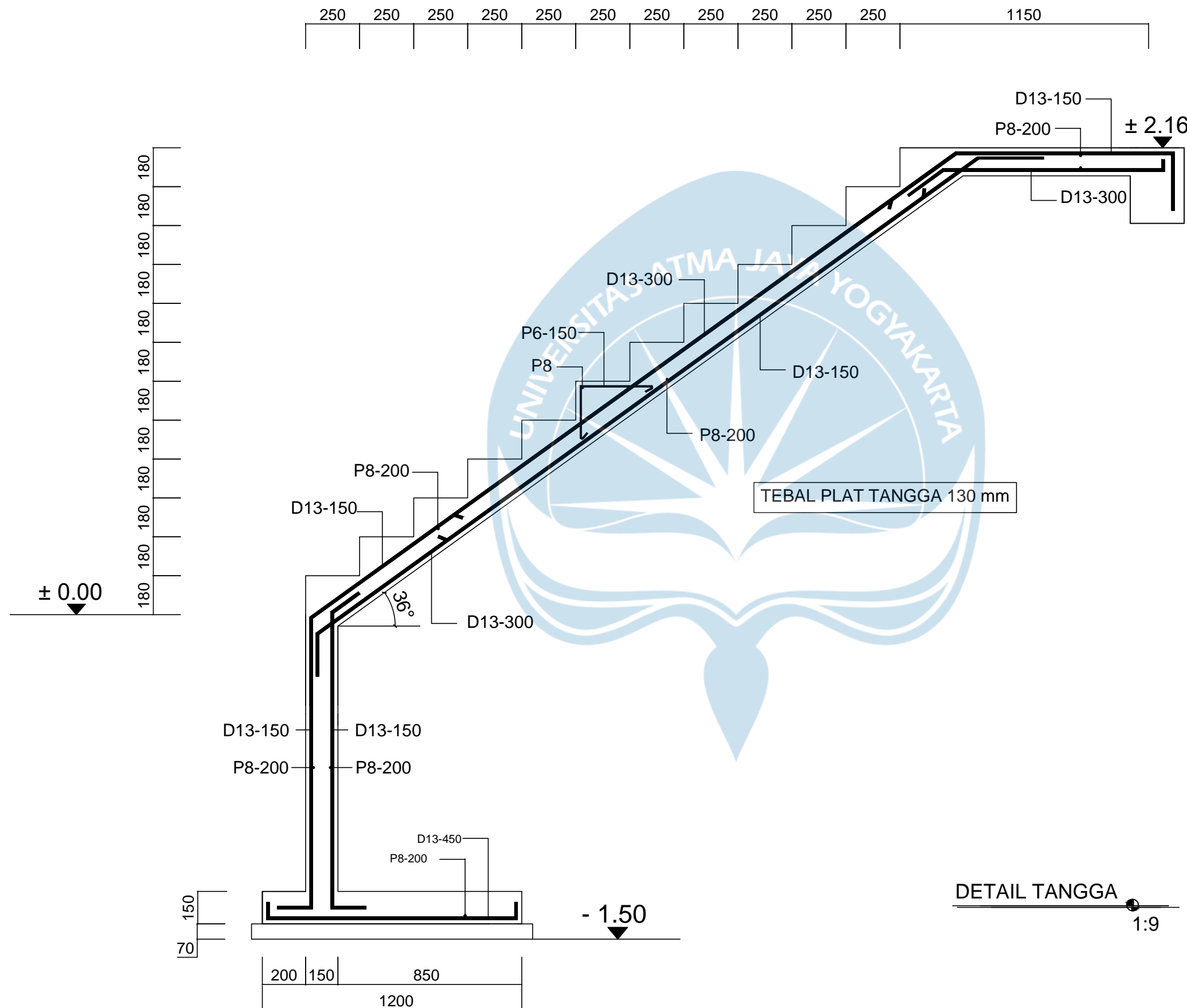



PROGRAM STUDI TEKNIK SIPIL
 FAKULTAS TEKNIK
 UNIVERSITAS ATMA JAYA
 YOGYAKARTA

SPESIFIKASI

BETON : f_c' 25 MPa
 BAJA TULANGAN : BJTS-420
 BAJA : BJ - 37

ANGGOTA KELOMPOK :

SAMUEL NABABAN
 (190217720)
 JUAN PATRICK SOASA
 (190217677)
 RICHARDUS ALGA ADMAJA
 (190217656)

DOSEN PENGAJAR :

Ir. HARYANTO YW., M.T.
 VIENTI HADSARI, S.T., M.Eng., MECRES, Ph.D.
 DIDIT GUNAWAN PRASETYO JATI, S.Kom, M.Sc.

DOSEN PEMBIMBING :

SISWADI, S.T., M.T.

GAMBAR

SKALA

DENAH ATAP

1:100

KODE GAMBAR	NO GAMBAR	JML. GAMBAR
-------------	-----------	-------------

STR

23

26

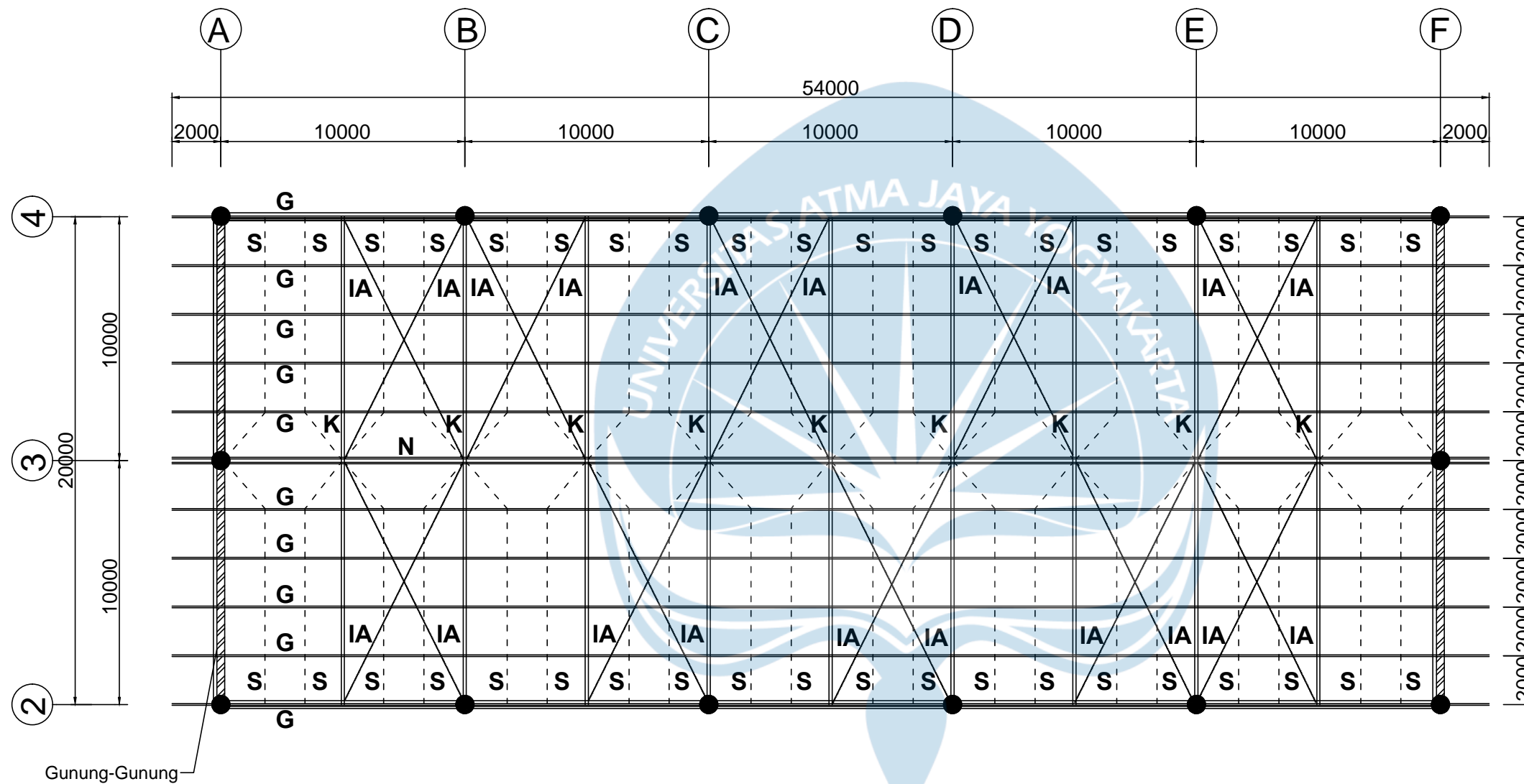

Gunung-Gunung

KETERANGAN

G	Gording C150x65x20x3,2
N	Nok 2C150x65x20x3,2
IA	Ikatan Angin Ø16
S	Sag-rod Ø10
K	Kuda-kuda Baja Siku

DENAH ATAP

1:100



PROGRAM STUDI TEKNIK SIPIL
 FAKULTAS TEKNIK
 UNIVERSITAS ATMA JAYA
 YOGYAKARTA

SPESIFIKASI

BETON : f_c' 25 MPa
 BAJA TULANGAN : BJTS-420
 BAJA : BJ - 37
 BAUT : A325

ANGGOTA KELOMPOK :

SAMUEL NABABAN
 (190217720)
 JUAN PATRICK SOASA
 (190217677)
 RICHARDUS ALGA ADMAJA
 (190217656)

DOSEN PENGAJAR :

Ir. HARYANTO YW., M.T.
 VIENTI HADSARI, S.T., M.Eng., MECRES, Ph.D.
 DIDIT GUNAWAN PRASETYO JATI, S.Kom, M.Sc.

DOSEN PEMBIMBING :

SISWADI, S.T., M.T.

GAMBAR

SKALA

RENCANA
 KUDA-KUDA BAJA

1:32

KODE GAMBAR NO GAMBAR JML. GAMBAR

STR 24 26

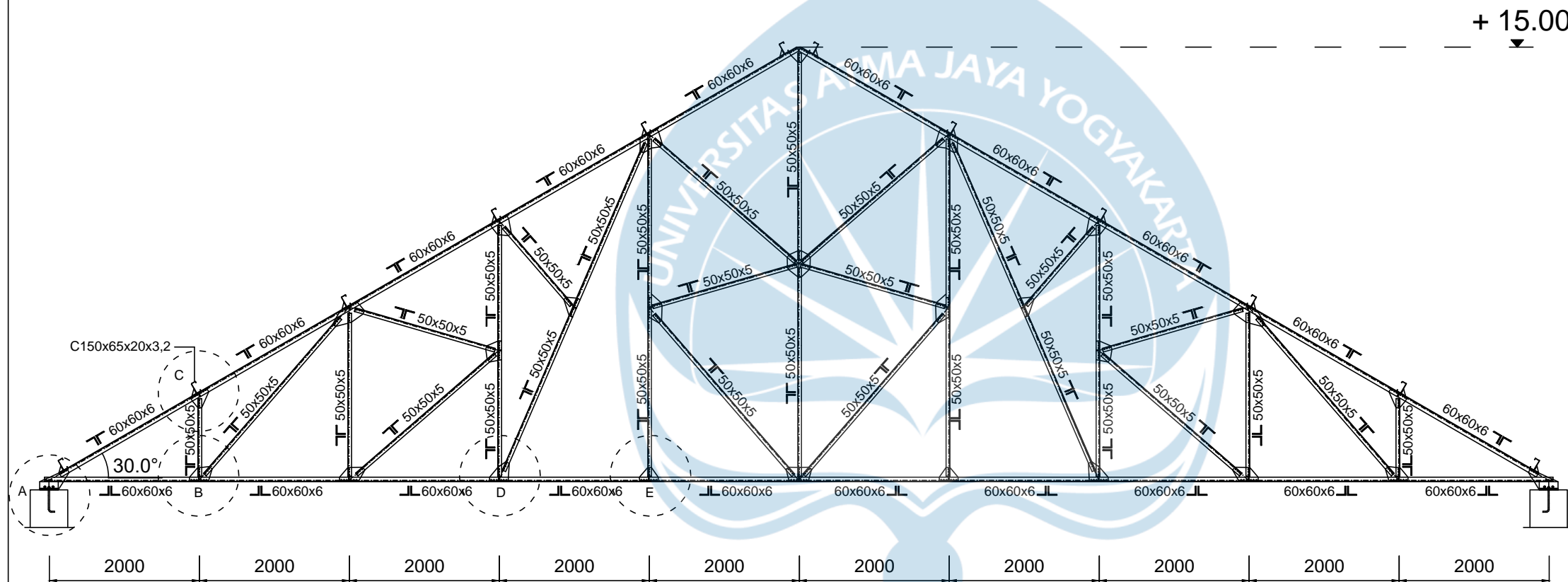

RENCANA KUDA-KUDA BAJA
 1:32

KETERANGAN :

PROFIL	PLAT SIMPUL	SAMBUNGAN BAUT
 	10 mm	3 baut \varnothing 12 mm Jarak antar baut 35 mm Jarak baut ke tepi 25 mm



PROGRAM STUDI TEKNIK SIPIL
 FAKULTAS TEKNIK
 UNIVERSITAS ATMA JAYA
 YOGYAKARTA

SPESIFIKASI

BETON : f_c' 25 MPa
 BAJA TULANGAN : BJTS-420
 BAJA : BJ - 37
 BAUT : A325

ANGGOTA KELOMPOK :

SAMUEL NABABAN
 (190217720)
 JUAN PATRICK SOASA
 (190217677)
 RICHARDUS ALGA ADMAJA
 (190217656)

DOSEN PENGAJAR :

Ir. HARYANTO YW., M.T.
 VIENTI HADSARI, S.T., M.Eng., MECRES, Ph.D.
 DIDIT GUNAWAN PRASETYO JATI, S.Kom, M.Sc.

DOSEN PEMBIMBING :

SISWADI, S.T., M.T.

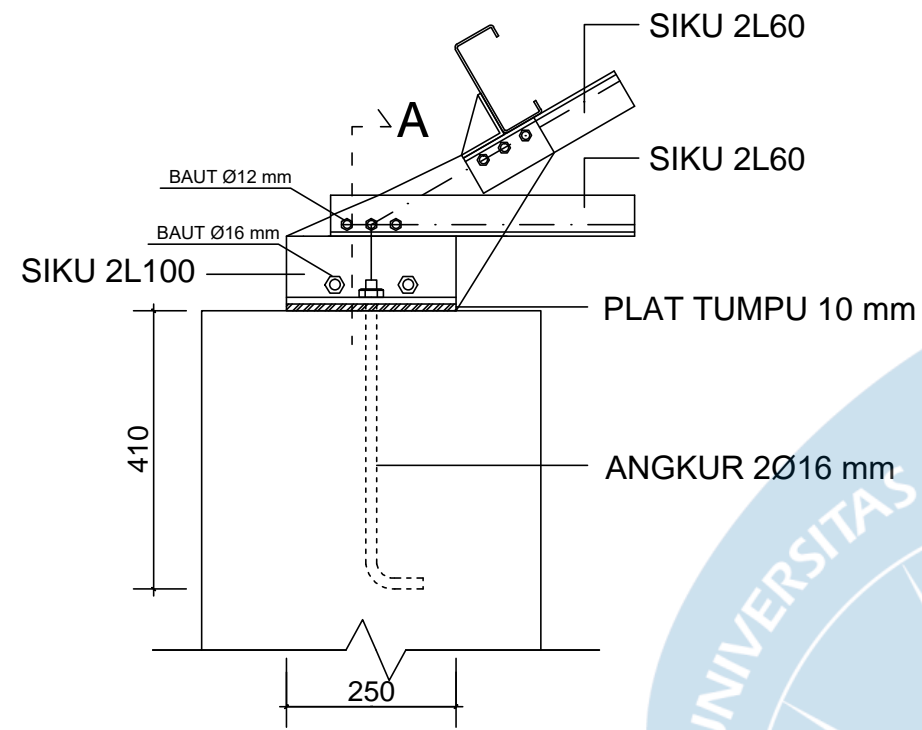

DETAIL A DUDUKAN KUDA - KUDA
 1:5

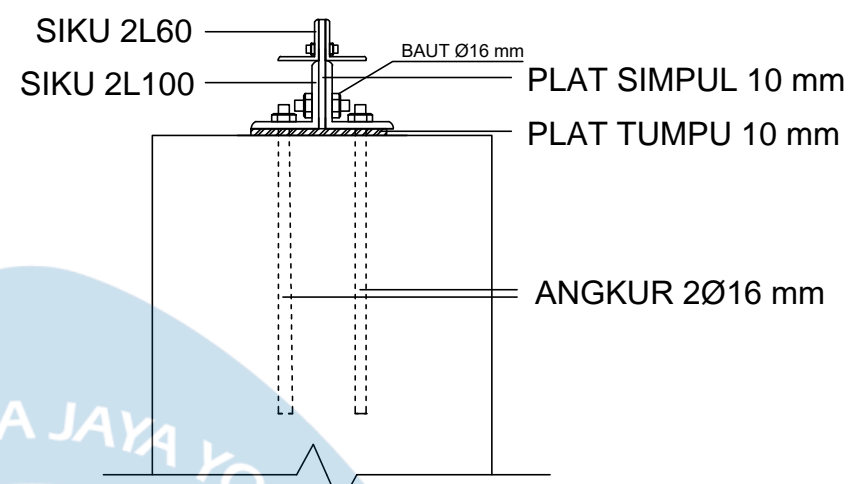

POTONGAN A
 1:5

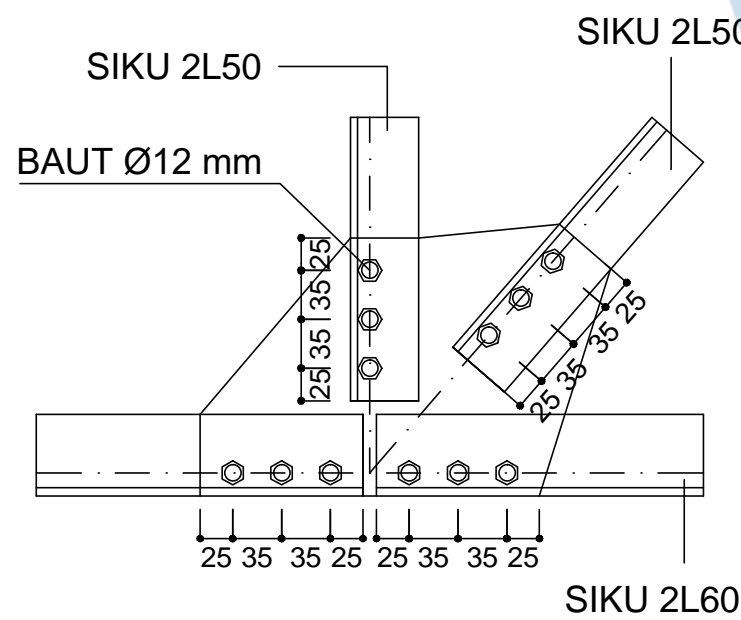

DETAIL B SAMBUNGAN BAUT
 1:2,5

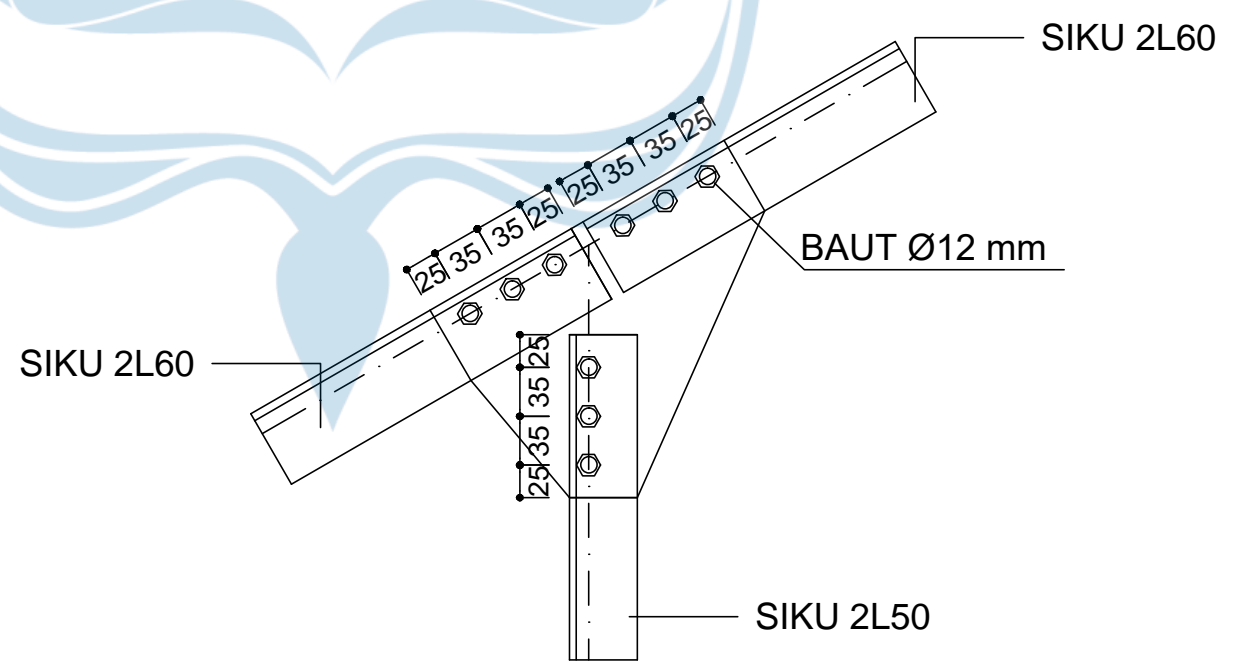

DETAIL C SAMBUNGAN BAUT
 1:2,5

GAMBAR		SKALA
DETAIL SAMBUNGAN KUDA-KUDA BAJA		1:5
KODE GAMBAR	NO GAMBAR	JML. GAMBAR
STR	25	26

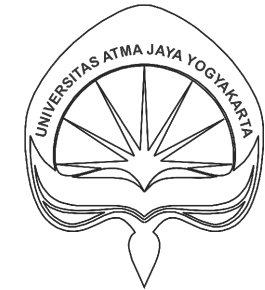

PROGRAM STUDI TEKNIK SIPIL
 FAKULTAS TEKNIK
 UNIVERSITAS ATMA JAYA
 YOGYAKARTA

SPESIFIKASI

BETON : f_c' 25 MPa
 BAJA TULANGAN : BJTS-420
 BAJA : BJ - 37
 BAUT : A325

ANGGOTA KELOMPOK :

SAMUEL NABABAN
 (190217720)
 JUAN PATRICK SOASA
 (190217677)
 RICHARDUS ALGA ADMAJA
 (190217656)

DOSEN PENGAJAR :

Ir. HARYANTO YW., M.T.
 VIENTI HADSARI, S.T., M.Eng., MECRES, Ph.D.
 DIDIT GUNAWAN PRASETYO JATI, S.Kom, M.Sc.

DOSEN PEMBIMBING :

SISWADI, S.T., M.T.

GAMBAR

SKALA

DETAIL SAMBUNGAN
 KUDA-KUDA BAJA

1:5

KODE GAMBAR	NO GAMBAR	JML. GAMBAR
-------------	-----------	-------------

STR	26	26
-----	----	----

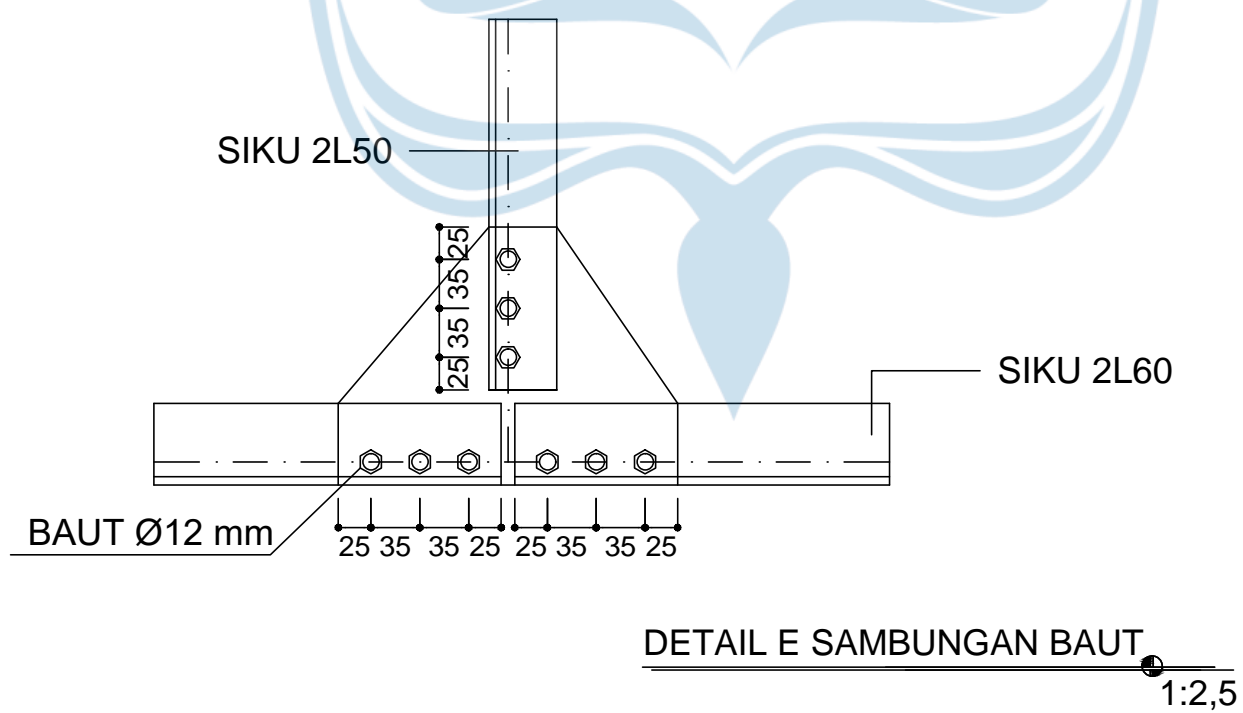
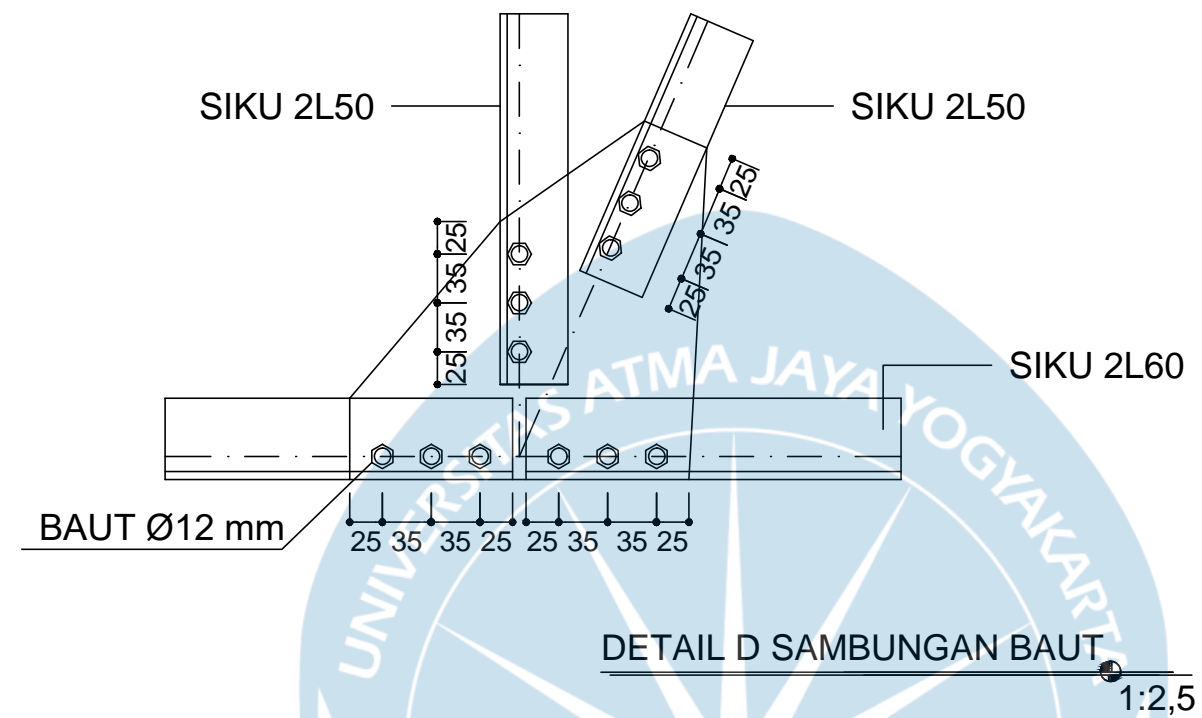

Lampiran B.2. Gambar Arsitektur **DAFTAR GAMBAR ARSITEKTUR**
GEDUNG PENGELOLA TAMAN REKREASI SAMARINDA

NO	KODE	NO. GAMBAR	NAMA GAMBAR	SKALA
1	ARS	01	DAFTAR GAMBAR ARSITEKTUR	1:100
2	ARS	02	AREA EXISTING	1:120
3	ARS	03	DENAH AREA PEKERJAAN	1:120
4	ARS	04	DENAH LANTAI 1	1:110
5	ARS	05	DENAH LANTAI 2	1:110
6	ARS	06	TAMPAK DEPAN	1:100
7	ARS	07	TAMPAK SAMPING KANAN	1:100
8	ARS	08	TAMPAK BELAKANG	1:100
9	ARS	09	TAMPAK SAMPING KIRI	1:100
10	ARS	10	POTONGAN A-A	1:100
11	ARS	11	POTONGAN B-B	1:100
12	ARS	12	DENAH KOLOM PRAKTIS LANTAI 1	1:100
13	ARS	13	DENAH KOLOM PRAKTIS LANTAI 2	1:100
14	ARS	14	DENAH BALOK LATEI LANTAI 1	1:100
15	ARS	15	DENAH BALOK LATEI LANTAI 2	1:100
16	ARS	16	RENCANA PINTU & JENDELA LANTAI 1	1:100
17	ARS	17	RENCANA PINTU & JENDELA LANTAI 2	1:100
18	ARS	18	DETAIL PINTU DAN JENDELA LANTAI 1	1:20
19	ARS	19	DETAIL PINTU DAN JENDELA LANTAI 1	1:20
20	ARS	20	DETAIL PINTU DAN JENDELA LANTAI 2	1:20
21	ARS	21	DETAIL PINTU DAN JENDELA LANTAI 2	1:20
22	ARS	22	RENCANA PLAFON LANTAI 1	1:100
23	ARS	23	RENCANA PLAFON LANTAI 2	1:100
24	ARS	24	DETAIL PLAFON	1:100
25	ARS	25	MODUL RAILING TANGGA	1:15
26	ARS	26	MODUL RAILING BALKON & SELASAR LANTAI 2	1:15
27	ARS	27	DENAH TOILET	1:20
28	ARS	28	POTONGAN A-A TOILET	1:20
29	ARS	29	POTONGAN B-B TOILET	1:20
30	ARS	30	DENAH POLA LANTAI 1	1:100
31	ARS	31	DENAH POLA LANTAI 2	1:100

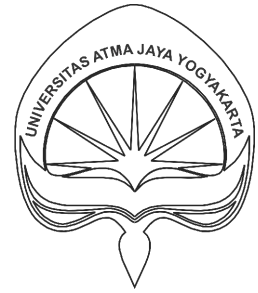

PROGRAM STUDI TEKNIK SIPIL
 FAKULTAS TEKNIK
 UNIVERSITAS ATMA JAYA
 YOGYAKARTA

SPESIFIKASI

ANGGOTA KELOMPOK :

SAMUEL NABABAN
 (190217720)
 JUAN PATRICK SOASA
 (190217677)
 RICHARDUS ALGA ADMAJA
 (190217656)

DOSEN PENGAJAR :

Ir. HARYANTO YW., M.T.
 VIENTI HADSARI, S.T., M.Eng., MECRES, Ph.D.
 DIDIT GUNAWAN PRASETYO JATI, S.Kom, M.Sc.

DOSEN PEMBIMBING :

SISWADI, S.T., M.T.

GAMBAR	SKALA
DAFTAR GAMBAR ARSITEKTUR	1:100

KODE GAMBAR	NO GAMBAR	JML. GAMBAR
ARS	01	31

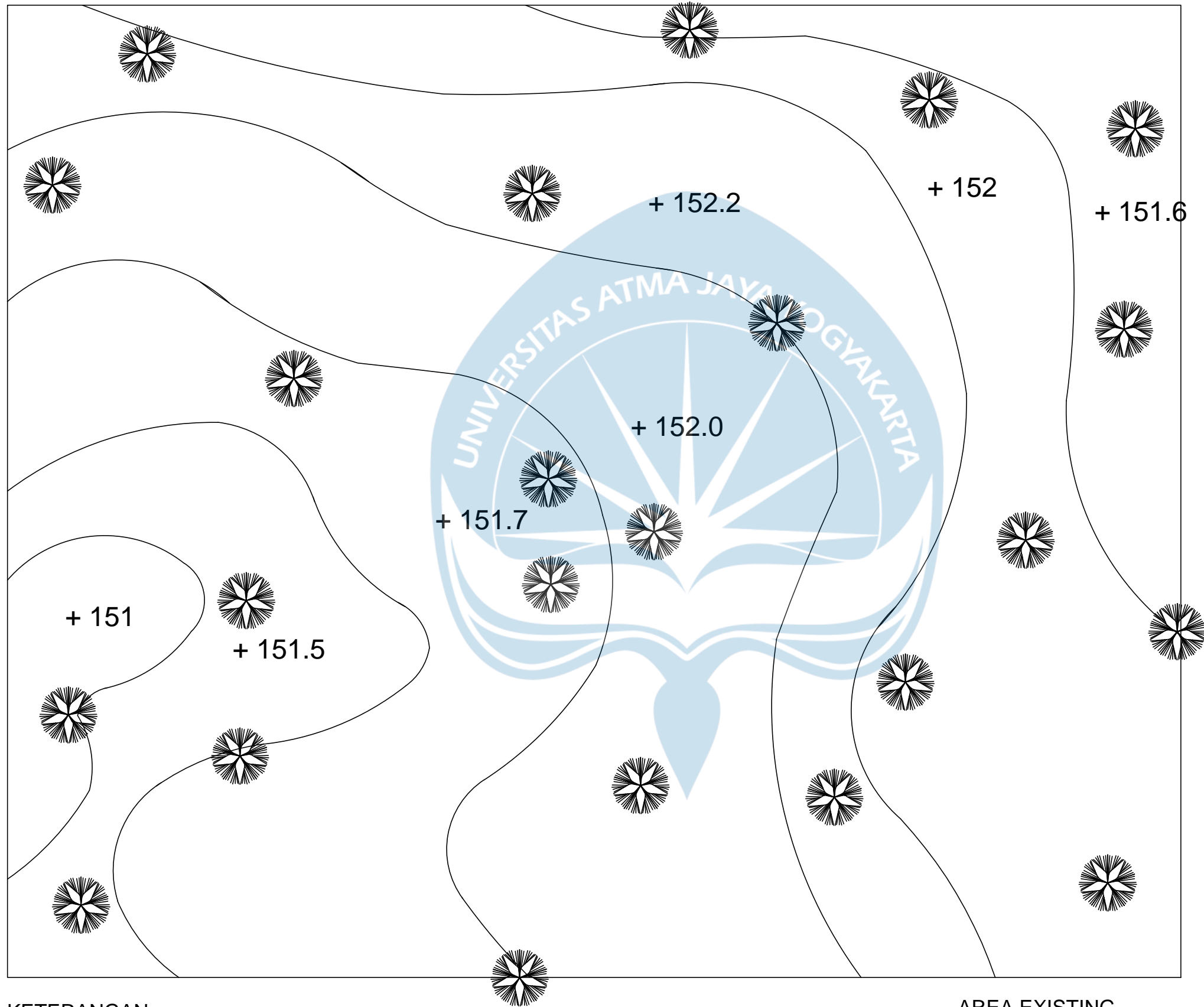

KETERANGAN
+151.5 = ± 0.00

AREA EXISTING
1:120



PROGRAM STUDI TEKNIK SIPIL
FAKULTAS TEKNIK
UNIVERSITAS ATMA JAYA
YOGYAKARTA

SPESIFIKASI
LUAS LAHAN 4060 m²

ANGGOTA KELOMPOK :
SAMUEL NABABAN
(190217720)
JUAN PATRICK SOASA
(190217677)
RICHARDUS ALGA ADMAJA
(190217656)

DOSEN PENGAJAR :
Ir. HARYANTO YW., M.T.
VIENTI HADSARI, S.T., M.Eng., MECRES, Ph.D.
DIDIT GUNAWAN PRASETYO JATI, S.Kom, M.Sc.

DOSEN PEMBIMBING :
SISWADI, S.T., M.T.

GAMBAR		SKALA
AREA EXISTING		1:120
KODE GAMBAR	NO GAMBAR	JML. GAMBAR
ARS	02	31



PROGRAM STUDI TEKNIK SIPIL
 FAKULTAS TEKNIK
 UNIVERSITAS ATMA JAYA
 YOGYAKARTA

SPESIFIKASI
 PAGAR KELILING 256 m'

ANGGOTA KELOMPOK :
 SAMUEL NABABAN
 (190217720)
 JUAN PATRICK SOASA
 (190217677)
 RICHARDUS ALGA ADMAJA
 (190217656)

DOSEN PENGAJAR :
 Ir. HARYANTO YW., M.T.
 VIENTI HADSARI, S.T., M.Eng., MECRES, Ph.D.
 DIDIT GUNAWAN PRASETYO JATI, S.Kom, M.Sc.

DOSEN PEMBIMBING :
 SISWADI, S.T., M.T.

GAMBAR	SKALA
--------	-------

DENAH AREA PEKERJAAN	1:120
----------------------	-------

KODE GAMBAR	NO GAMBAR	JML. GAMBAR
ARS	03	31

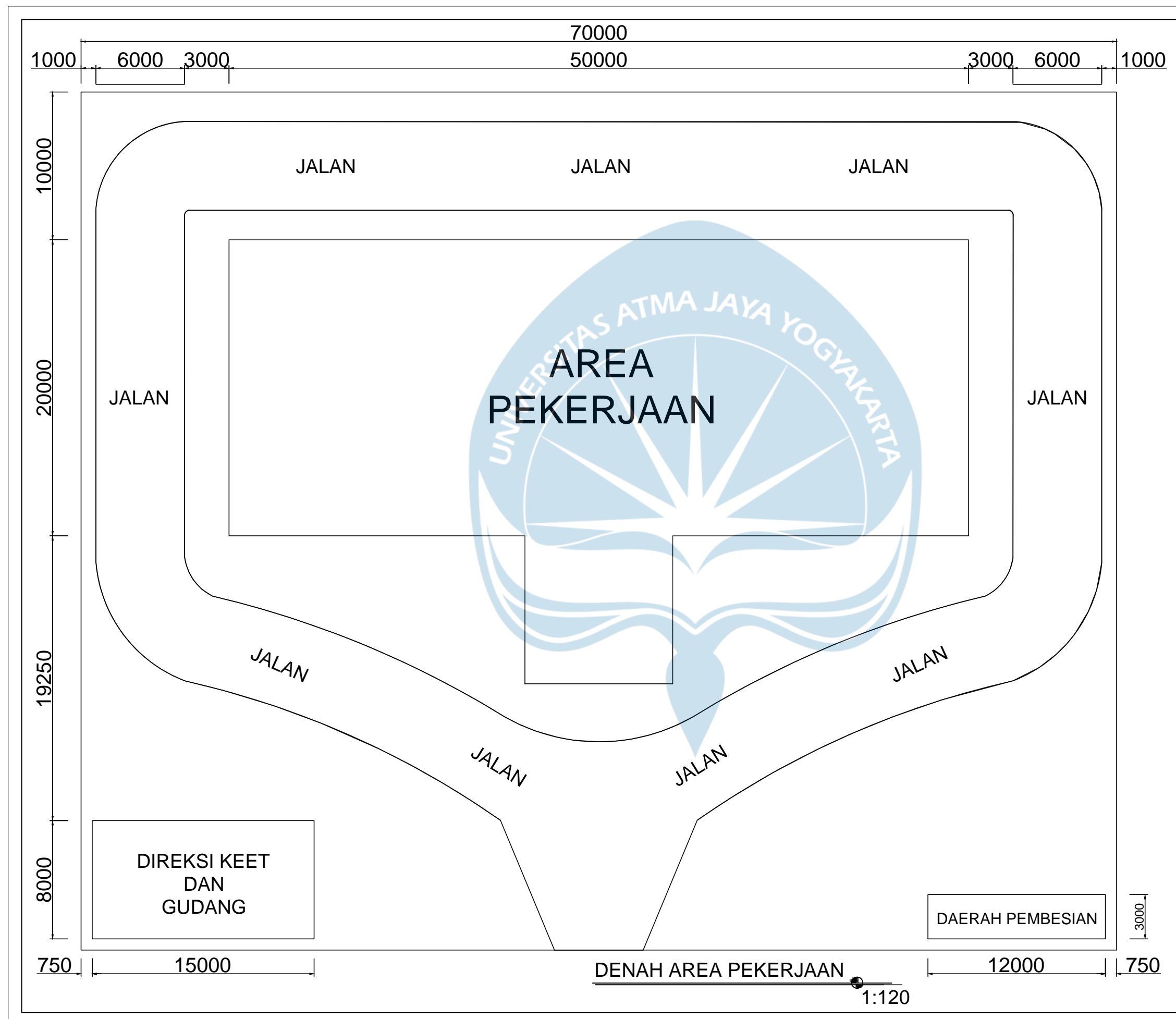

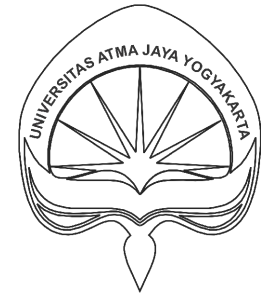

PROGRAM STUDI TEKNIK SIPIL
 FAKULTAS TEKNIK
 UNIVERSITAS ATMA JAYA
 YOGYAKARTA

SPESIFIKASI

PASANGAN BATU BATA t : 11 cm
 PLESTERAN + ACIAN t : 4 cm (2 sisi)

ANGGOTA KELOMPOK :

SAMUEL NABABAN
 (190217720)
JUAN PATRICK SOASA
 (190217677)
RICHARDUS ALGA ADMAJA
 (190217656)

DOSEN PENGAJAR :

Ir. HARYANTO YW., M.T.
 VIENTI HADSARI, S.T., M.Eng., MECRES, Ph.D.
 DIDIT GUNAWAN PRASETYO JATI, S.Kom, M.Sc.

DOSEN PEMBIMBING :

SISWADI, S.T., M.T.

GAMBAR

SKALA

DENAH LANTAI 1

1:110

KODE GAMBAR	NO GAMBAR	JML. GAMBAR
ARS	04	31

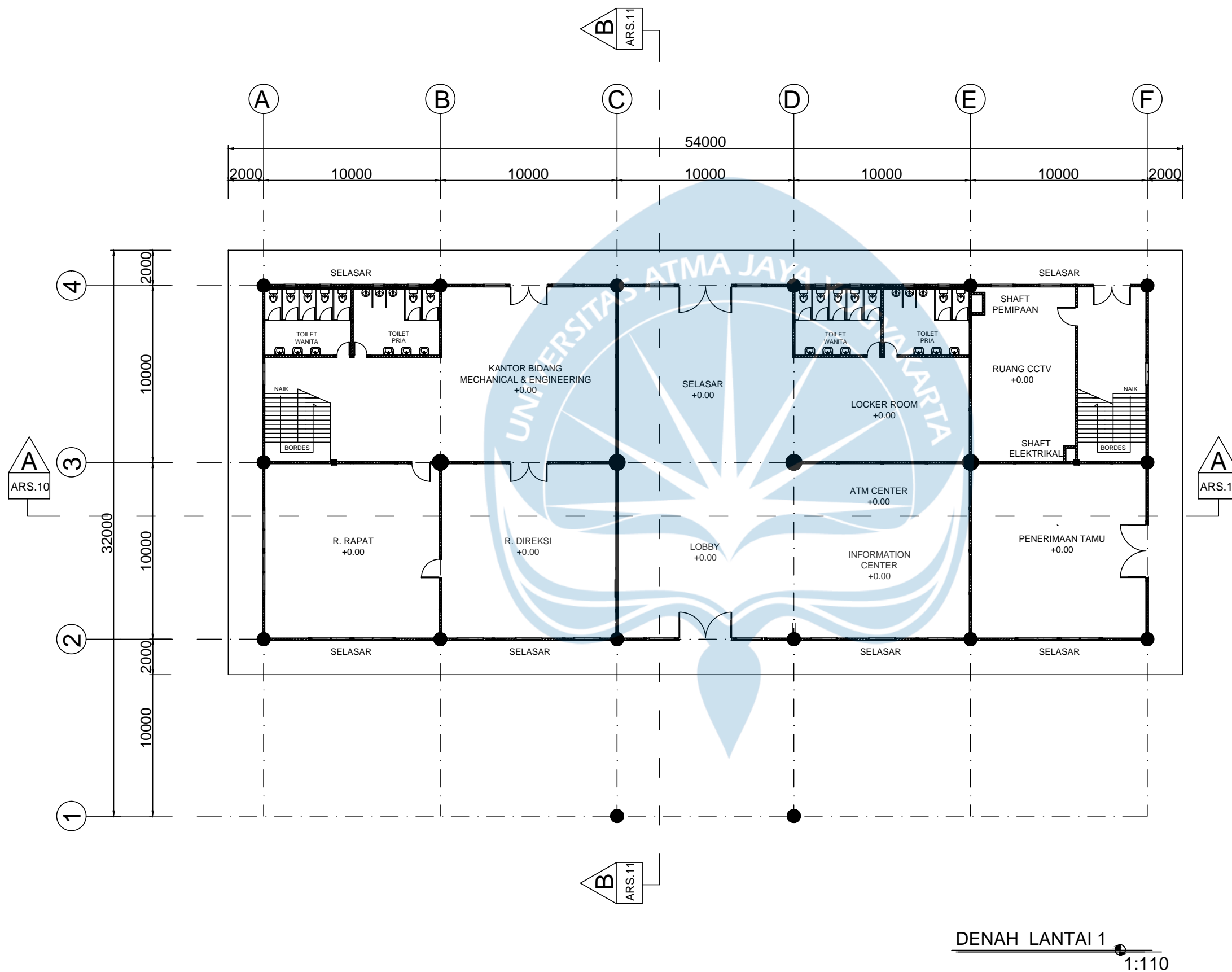

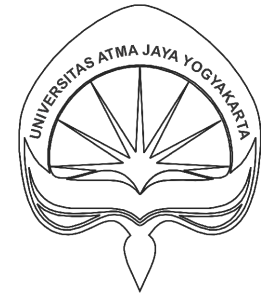

PROGRAM STUDI TEKNIK SIPIL
 FAKULTAS TEKNIK
 UNIVERSITAS ATMA JAYA
 YOGYAKARTA

SPESIFIKASI

PASANGAN BATU BATA t : 11 cm
 PLESTERAN + ACIAN t : 4 cm (2 sisi)

ANGGOTA KELOMPOK :

SAMUEL NABABAN
 (190217720)
JUAN PATRICK SOASA
 (190217677)
RICHARDUS ALGA ADMAJA
 (190217656)

DOSEN PENGAJAR :

Ir. HARYANTO YW., M.T.
 VIENTI HADSARI, S.T., M.Eng., MECRES, Ph.D.
 DIDIT GUNAWAN PRASETYO JATI, S.Kom, M.Sc.

DOSEN PEMBIMBING :

SISWADI, S.T., M.T.

GAMBAR

SKALA

DENAH LANTAI 2

1:110

KODE GAMBAR NO GAMBAR JML. GAMBAR

ARS

05

31

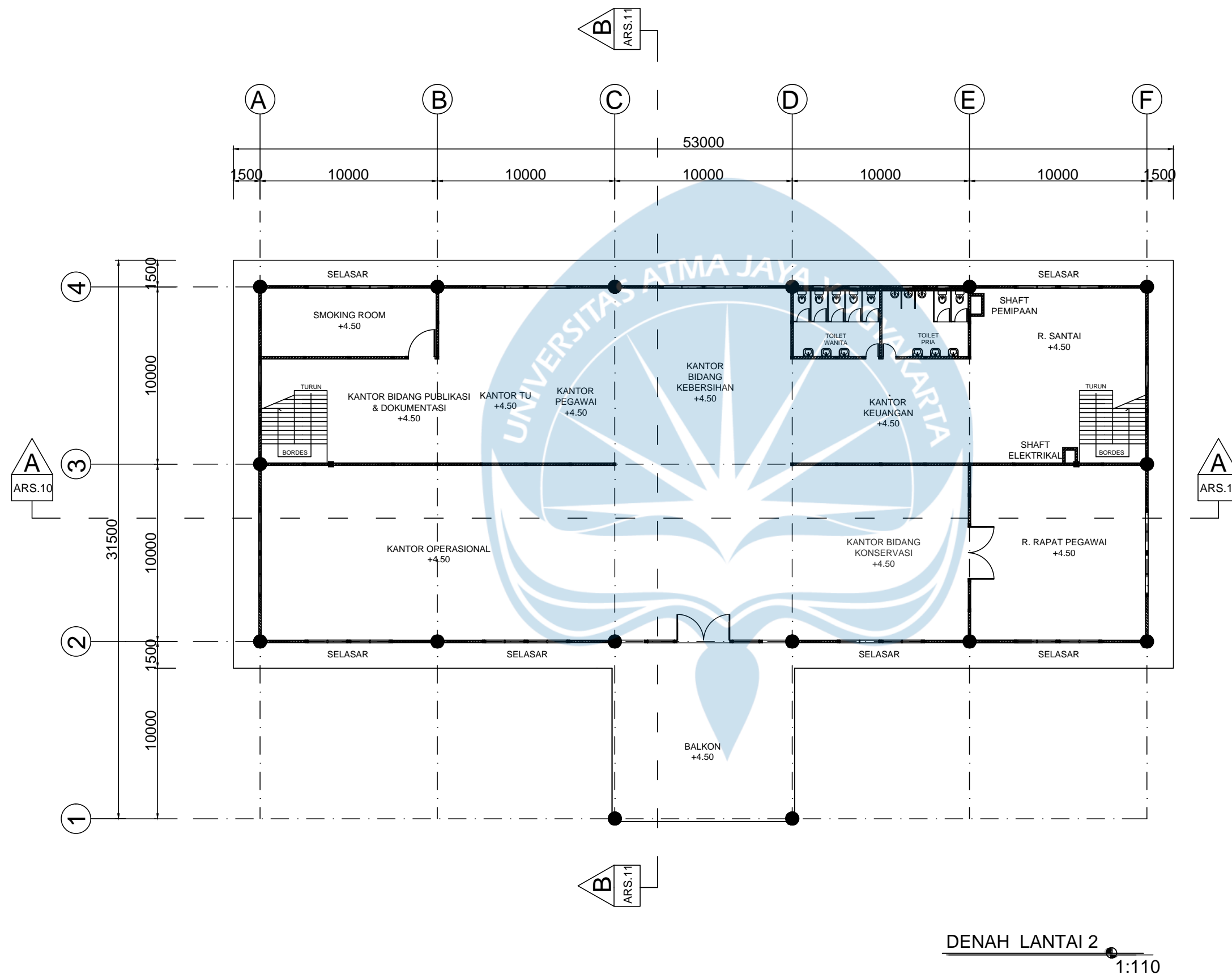

DENAH LANTAI 2
 1:110



PROGRAM STUDI TEKNIK SIPIL
 FAKULTAS TEKNIK
 UNIVERSITAS ATMA JAYA
 YOGYAKARTA

SPESIFIKASI

ANGGOTA KELOMPOK :

SAMUEL NABABAN
 (190217720)
 JUAN PATRICK SOASA
 (190217677)
 RICHARDUS ALGA ADMAJA
 (190217656)

DOSEN PENGAJAR :

Ir. HARYANTO YW., M.T.
 VIENTI HADSARI, S.T., M.Eng., MECRES, Ph.D.
 DIDIT GUNAWAN PRASETYO JATI, S.Kom, M.Sc.

DOSEN PEMBIMBING :

SISWADI, S.T., M.T.

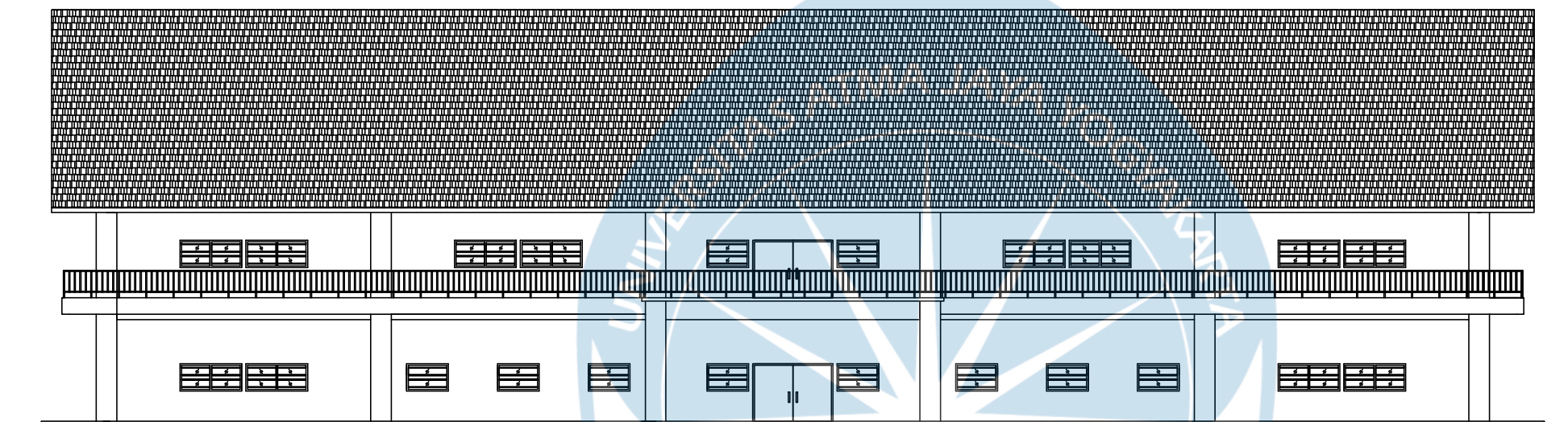

TAMPAK DEPAN

1:100

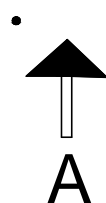
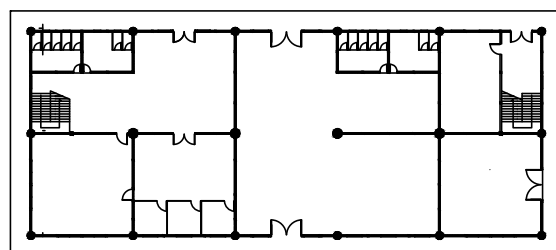

GAMBAR		SKALA
TAMPAK DEPAN		1:100
KODE GAMBAR	NO GAMBAR	JML. GAMBAR
ARS	06	31



PROGRAM STUDI TEKNIK SIPIL
 FAKULTAS TEKNIK
 UNIVERSITAS ATMA JAYA
 YOGYAKARTA

SPESIFIKASI

ANGGOTA KELOMPOK :

SAMUEL NABABAN
 (190217720)
 JUAN PATRICK SOASA
 (190217677)
 RICHARDUS ALGA ADMAJA
 (190217656)

DOSEN PENGAJAR :

Ir. HARYANTO YW., M.T.
 VIENTI HADSARI, S.T., M.Eng., MECRES, Ph.D.
 DIDIT GUNAWAN PRASETYO JATI, S.Kom, M.Sc.

DOSEN PEMBIMBING :

SISWADI, S.T., M.T.

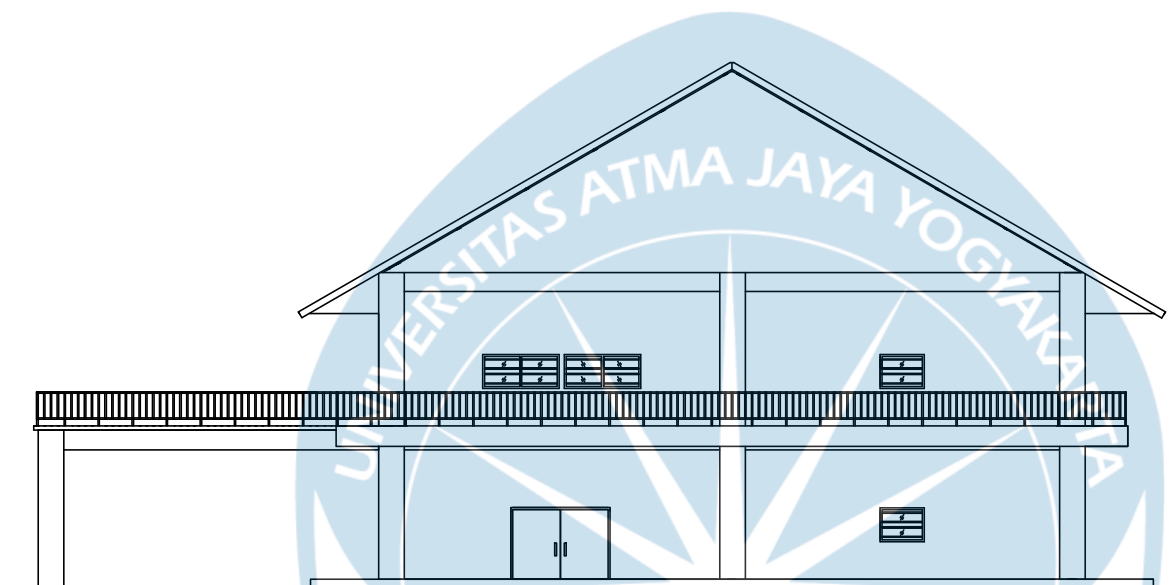

TAMPAK SAMPING KANAN 1:100

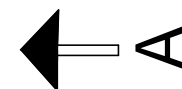
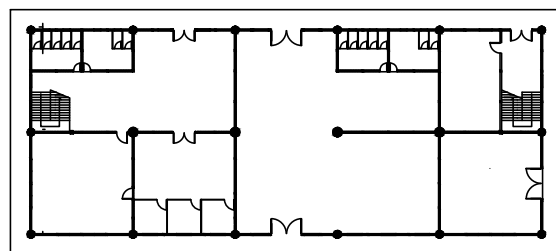

GAMBAR	SKALA	
TAMPAK SAMPING KANAN	1:100	
KODE GAMBAR	NO GAMBAR	JML. GAMBAR
ARS	07	31



PROGRAM STUDI TEKNIK SIPIL
 FAKULTAS TEKNIK
 UNIVERSITAS ATMA JAYA
 YOGYAKARTA

SPESIFIKASI

ANGGOTA KELOMPOK :

SAMUEL NABABAN
 (190217720)

JUAN PATRICK SOASA
 (190217677)

RICHARDUS ALGA ADMAJA
 (190217656)

DOSEN PENGAJAR :

Ir. HARYANTO YW., M.T.

VIENTI HADSARI, S.T., M.Eng., MECRES, Ph.D.

DIDIT GUNAWAN PRASETYO JATI, S.Kom, M.Sc.

DOSEN PEMBIMBING :

SISWADI, S.T., M.T.

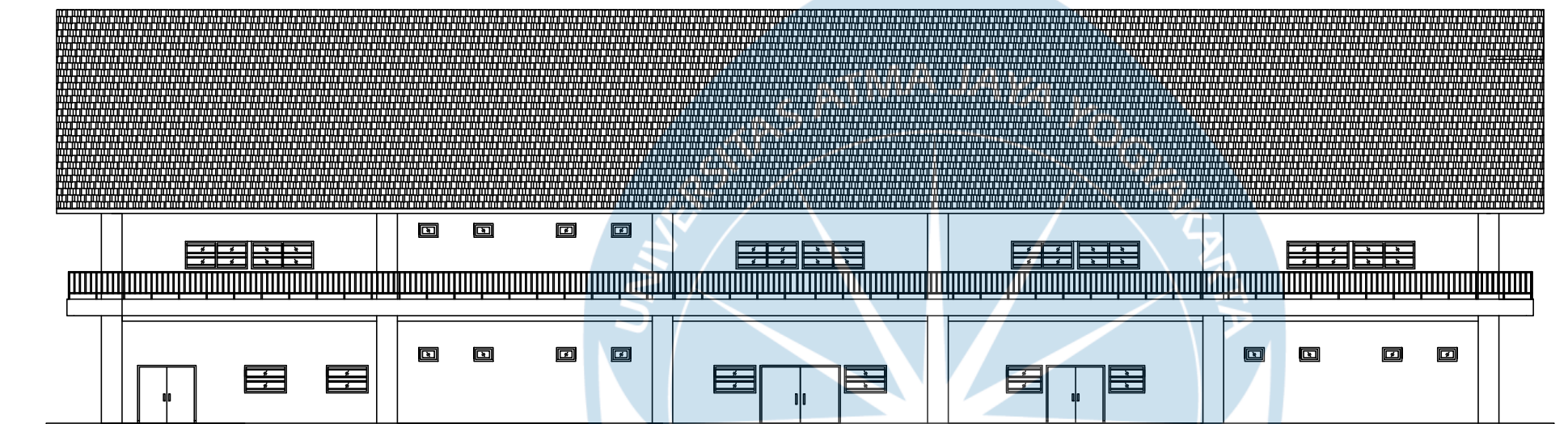

TAMPAK BELAKANG

1:100

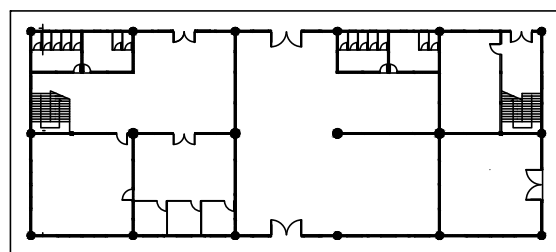
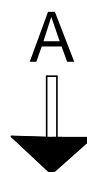

GAMBAR		SKALA
TAMPAK BELAKANG		1:100
KODE GAMBAR	NO GAMBAR	JML. GAMBAR
ARS	08	31



PROGRAM STUDI TEKNIK SIPIL
 FAKULTAS TEKNIK
 UNIVERSITAS ATMA JAYA
 YOGYAKARTA

SPESIFIKASI

ANGGOTA KELOMPOK :

SAMUEL NABABAN
 (190217720)
 JUAN PATRICK SOASA
 (190217677)
 RICHARDUS ALGA ADMAJA
 (190217656)

DOSEN PENGAJAR :

Ir. HARYANTO YW., M.T.
 VIENTI HADSARI, S.T., M.Eng., MECRES, Ph.D.
 DIDIT GUNAWAN PRASETYO JATI, S.Kom, M.Sc.

DOSEN PEMBIMBING :

SISWADI, S.T., M.T.

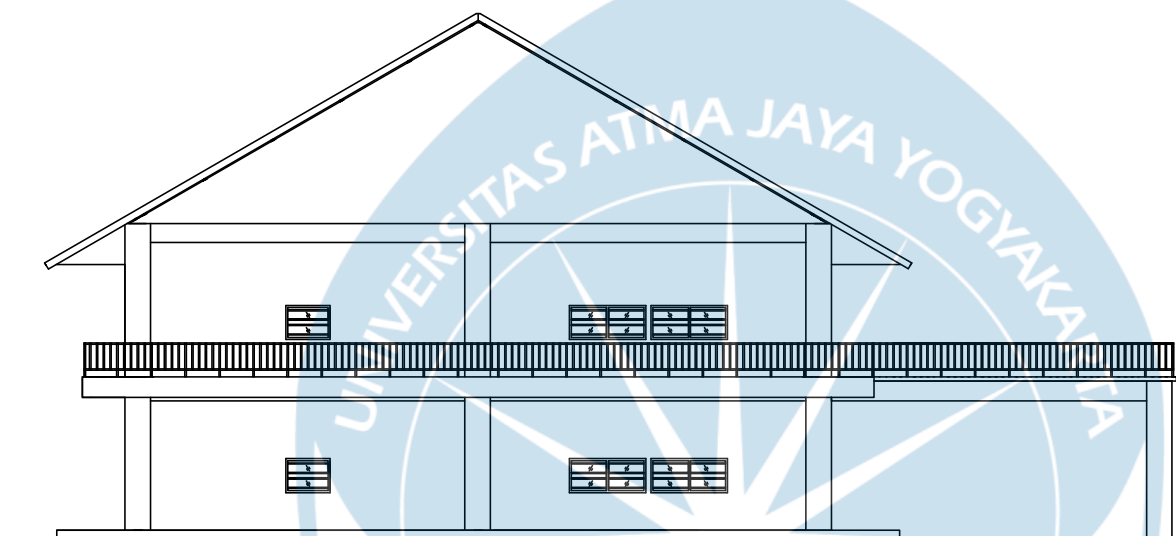

TAMPAK SAMPING KIRI

1:100

A →

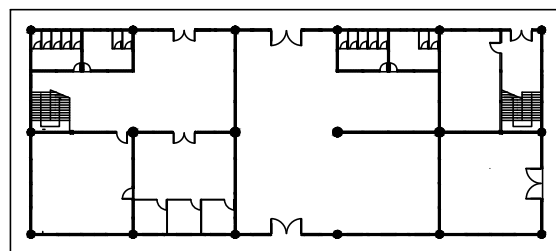

GAMBAR

SKALA

TAMPAK SAMPING
 KIRI

1:100

KODE GAMBAR NO GAMBAR JML. GAMBAR

ARS

09

31



PROGRAM STUDI TEKNIK SIPIL
 FAKULTAS TEKNIK
 UNIVERSITAS ATMA JAYA
 YOGYAKARTA

SPESIFIKASI

ANGGOTA KELOMPOK :

SAMUEL NABABAN
 (190217720)
 JUAN PATRICK SOASA
 (190217677)
 RICHARDUS ALGA ADMAJA
 (190217656)

DOSEN PENGAJAR :

Ir. HARYANTO YW., M.T.
 VIENTI HADSARI, S.T., M.Eng., MECRES, Ph.D.
 DIDIT GUNAWAN PRASETYO JATI, S.Kom, M.Sc.

DOSEN PEMBIMBING :

SISWADI, S.T., M.T.

GAMBAR	SKALA	
POTONGAN A-A	1:100	
KODE GAMBAR	NO GAMBAR	JML. GAMBAR
ARS	10	31

TOP ATAP
 + 15.00

RING BALK
 + 9.00

LANTAI 2
 + 4.50

LANTAI 1
 ± 0.00

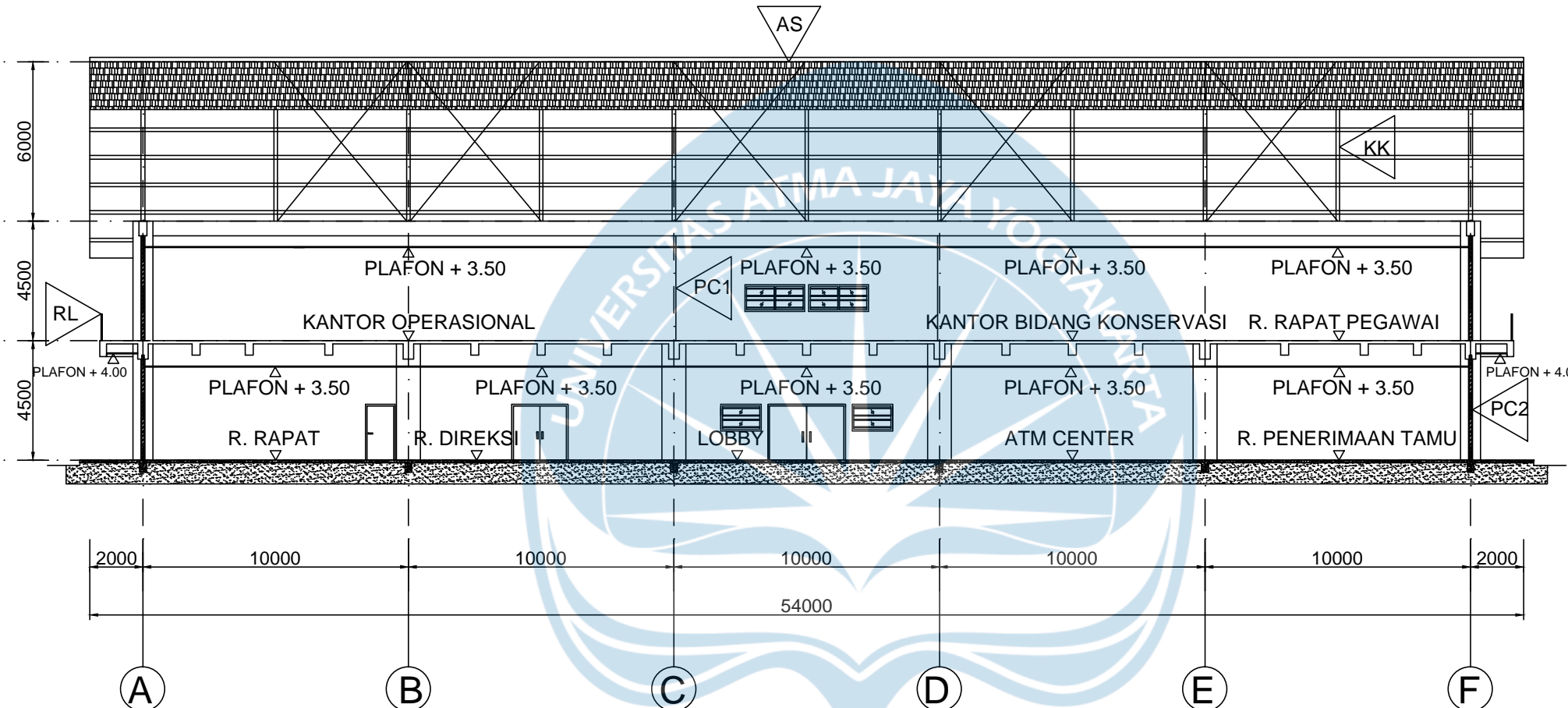

LEGENDA :

	= ATAP SIRAP
	= KUDA-KUDA BAJA
	= PLESTER + ACI FINISH CAT INTERIOR
	= PLESTER + ACI FINISH CAT WATERSHIELD
	= RAILING

POTONGAN A-A

1:100



PROGRAM STUDI TEKNIK SIPIL
FAKULTAS TEKNIK
UNIVERSITAS ATMA JAYA
YOGYAKARTA

SPESIFIKASI

ANGGOTA KELOMPOK :

SAMUEL NABABAN
(190217720)
JUAN PATRICK SOASA
(190217677)
RICHARDUS ALGA ADMAJA
(190217656)

DOSEN PENGAJAR :

Ir. HARYANTO YW., M.T.
VIENTI HADSARI, S.T., M.Eng., MECRES, Ph.D.
DIDIT GUNAWAN PRASETYO JATI, S.Kom, M.Sc.

DOSEN PEMBIMBING :

SISWADI, S.T., M.T.

GAMBAR

SKALA

POTONGAN B-B

1:100

KODE GAMBAR	NO GAMBAR	JML. GAMBAR
-------------	-----------	-------------

ARS	11	31
-----	----	----

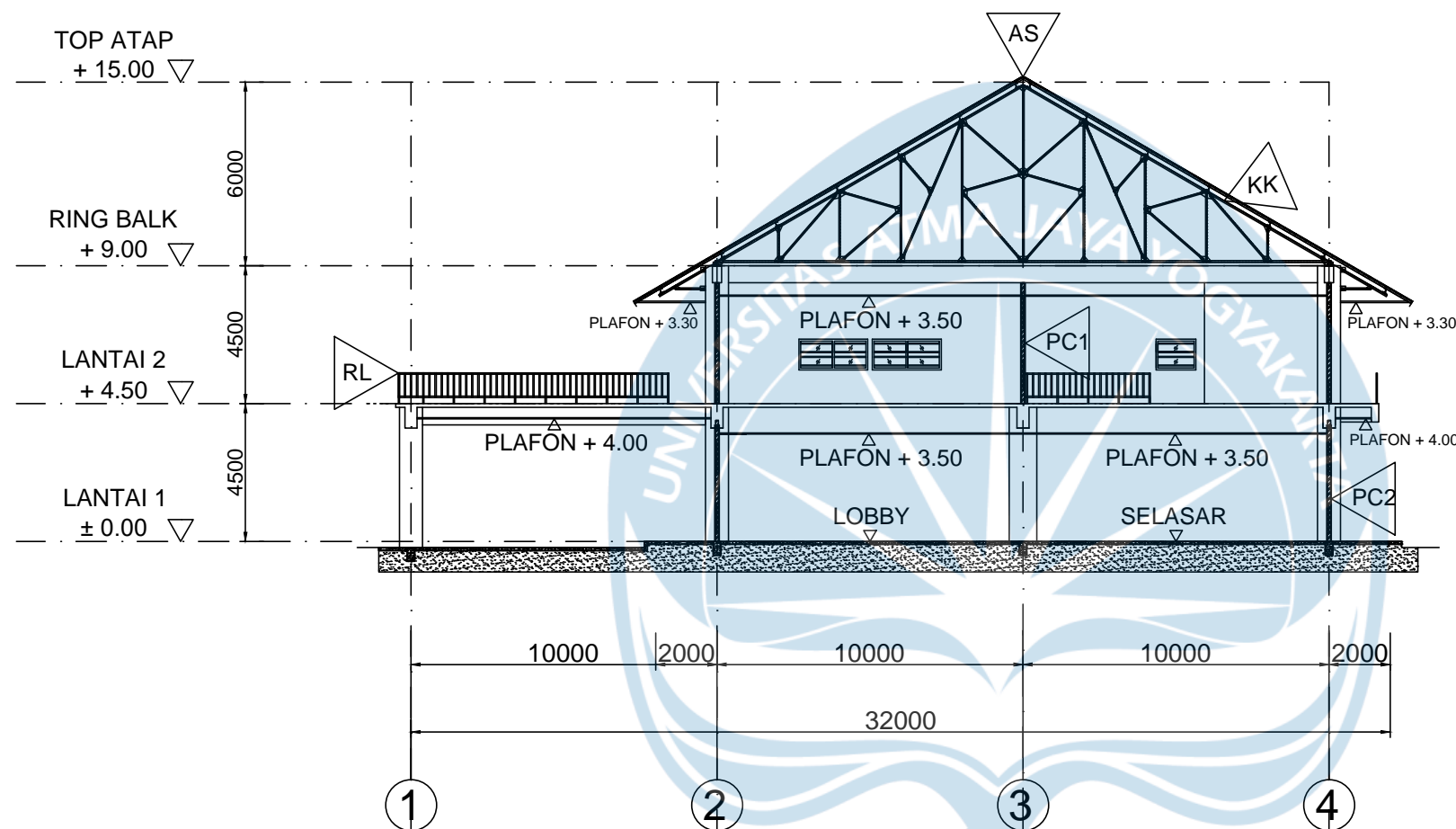

POTONGAN B-B
1:100

LEGENDA :

	= ATAP SIRAP
	= KUDA-KUDA BAJA
	= PLESTER + ACI FINISH CAT INTERIOR
	= PLESTER + ACI FINISH CAT WATERSHIELD
	= RAILING



PROGRAM STUDI TEKNIK SIPIL
 FAKULTAS TEKNIK
 UNIVERSITAS ATMA JAYA
 YOGYAKARTA

SPESIFIKASI

UK. KOLOM PRAKTIS : 11x11 cm

ANGGOTA KELOMPOK :

SAMUEL NABABAN
 (190217720)
JUAN PATRICK SOASA
 (190217677)
RICHARDUS ALGA ADMAJA
 (190217656)

DOSEN PENGAJAR :

Ir. HARYANTO YW., M.T.
 VIENTI HADSARI, S.T., M.Eng., MECRES, Ph.D.
 DIDIT GUNAWAN PRASETYO JATI, S.Kom, M.Sc.

DOSEN PEMBIMBING :

SISWADI, S.T., M.T.

GAMBAR

SKALA

DENAH KOLOM
 PRAKTIS LANTAI 1

1:100

KODE GAMBAR NO GAMBAR JML. GAMBAR

ARS 12 31

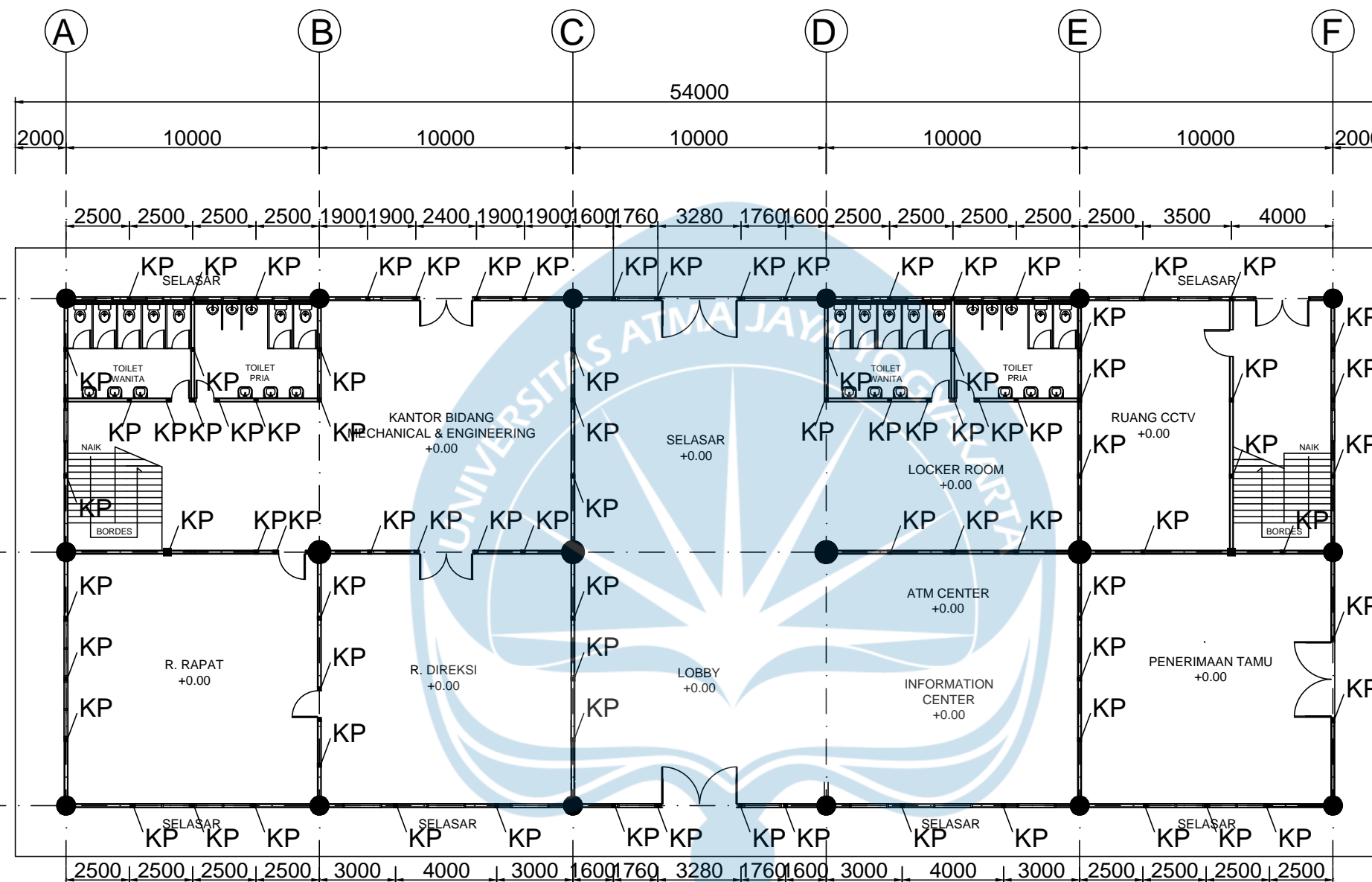

Jumlah :
 KP = 81 Kolom Praktis

DENAH KOLOM PRAKTIS LANTAI 1
 1:100



PROGRAM STUDI TEKNIK SIPIL
 FAKULTAS TEKNIK
 UNIVERSITAS ATMA JAYA
 YOGYAKARTA

SPESIFIKASI

UK. KOLOM PRAKTIS : 11x11 cm

ANGGOTA KELOMPOK :

SAMUEL NABABAN
 (190217720)
JUAN PATRICK SOASA
 (190217677)
RICHARDUS ALGA ADMAJA
 (190217656)

DOSEN PENGAJAR :

Ir. HARYANTO YW., M.T.
 VIENTI HADSARI, S.T., M.Eng., MECRES, Ph.D.
 DIDIT GUNAWAN PRASETYO JATI, S.Kom, M.Sc.

DOSEN PEMBIMBING :

SISWADI, S.T., M.T.

GAMBAR	SKALA
--------	-------

DENAH KOLOM PRAKTIS LANTAI 2	1:100
------------------------------	-------

KODE GAMBAR	NO GAMBAR	JML. GAMBAR
ARS	13	31

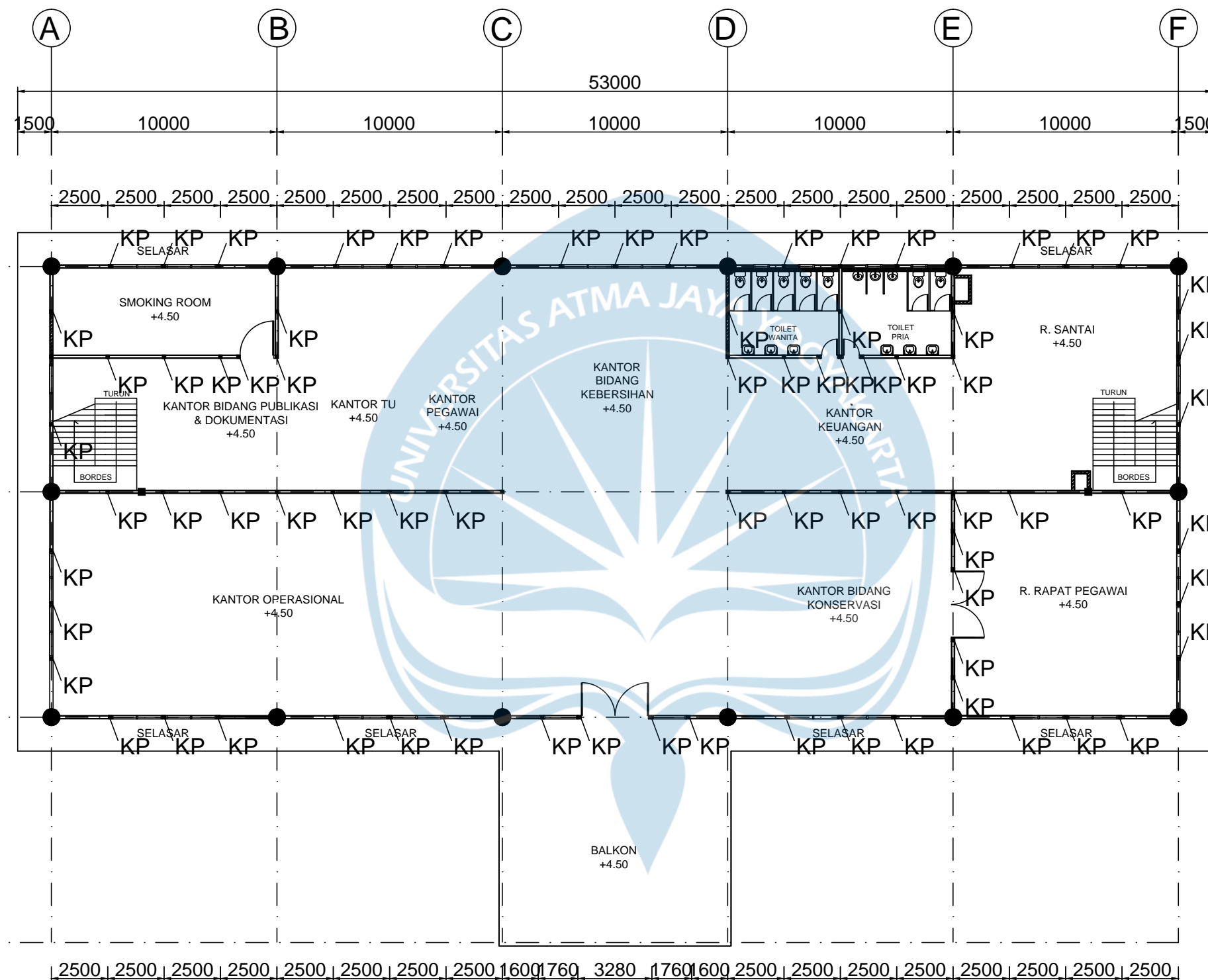

Jumlah :
 KP = 73 Kolom Praktis

DENAH KOLOM PRAKTIS LANTAI 2
 1:100



PROGRAM STUDI TEKNIK SIPIL
 FAKULTAS TEKNIK
 UNIVERSITAS ATMA JAYA
 YOGYAKARTA

SPESIFIKASI
 UK. BALOK LATEI 11x11 cm

ANGGOTA KELOMPOK :
 SAMUEL NABABAN
 (190217720)
 JUAN PATRICK SOASA
 (190217677)
 RICHARDUS ALGA ADMAJA
 (190217656)

DOSEN PENGAJAR :
 Ir. HARYANTO YW., M.T.
 VIENTI HADSARI, S.T., M.Eng., MECRES, Ph.D.
 DIDIT GUNAWAN PRASETYO JATI, S.Kom, M.Sc.

DOSEN PEMBIMBING :
 SISWADI, S.T., M.T.

GAMBAR		SKALA
DENAH BALOK LATEI LANTAI 1		1:100
KODE GAMBAR	NO GAMBAR	JML. GAMBAR
ARS	14	31

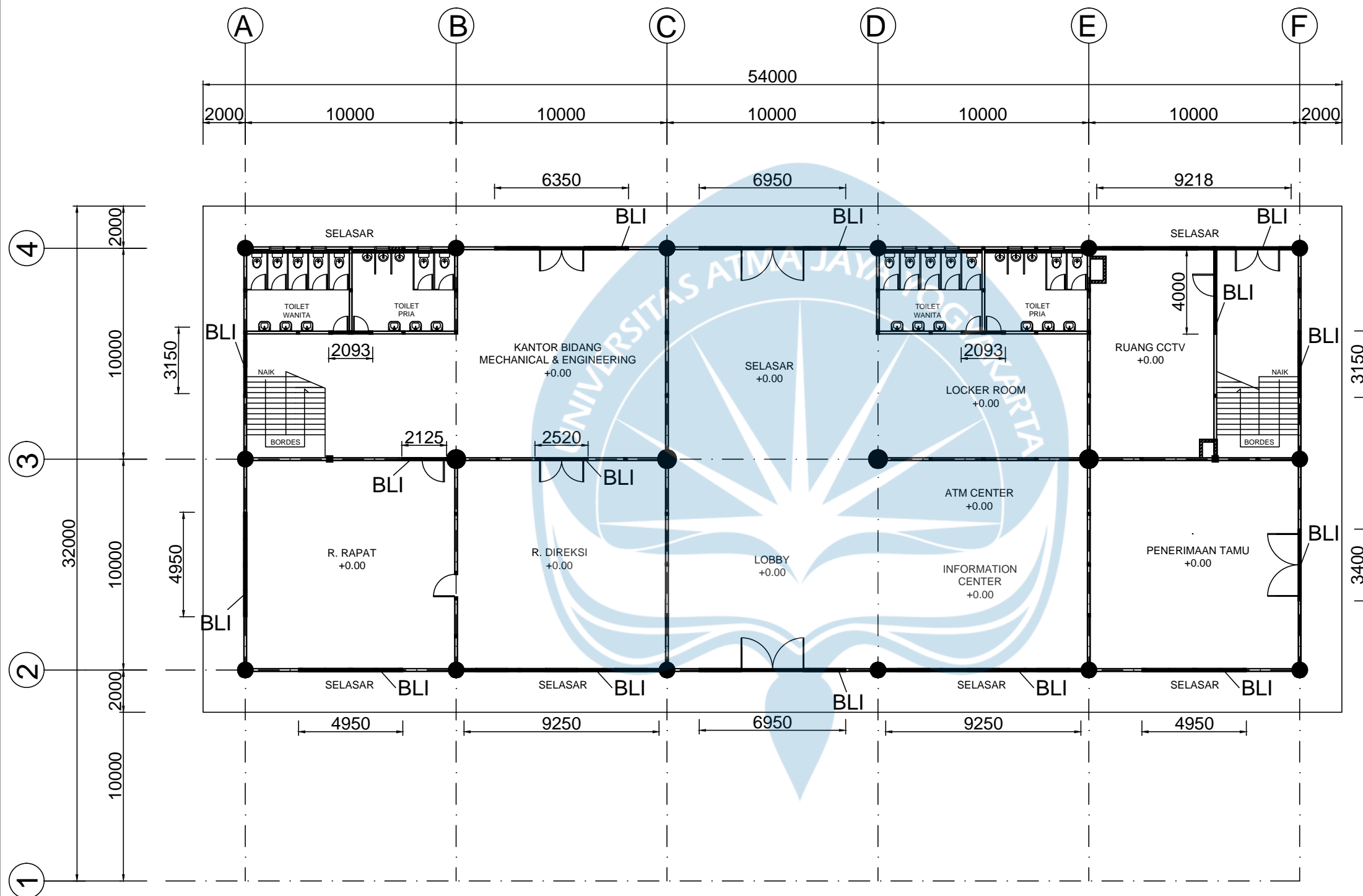

Total Panjang :
 BLI = 77,84 m

DENAH BALOK LATEI LANTAI 1
 1:100

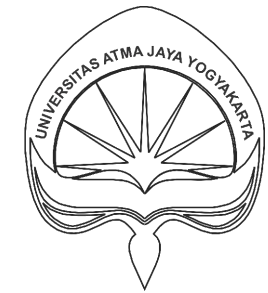

PROGRAM STUDI TEKNIK SIPIL
 FAKULTAS TEKNIK
 UNIVERSITAS ATMA JAYA
 YOGYAKARTA

SPESIFIKASI
 UK. BALOK LATEI 11x11 cm

ANGGOTA KELOMPOK :
 SAMUEL NABABAN
 (190217720)
 JUAN PATRICK SOASA
 (190217677)
 RICHARDUS ALGA ADMAJA
 (190217656)

DOSEN PENGAJAR :
 Ir. HARYANTO YW., M.T.
 VIENTI HADSARI, S.T., M.Eng., MECRES, Ph.D.
 DIDIT GUNAWAN PRASETYO JATI, S.Kom, M.Sc.

DOSEN PEMBIMBING :
 SISWADI, S.T., M.T.

GAMBAR	SKALA	
DENAH BALOK LATEI LANTAI 2	1:100	
KODE GAMBAR	NO GAMBAR	JML. GAMBAR
ARS	15	31

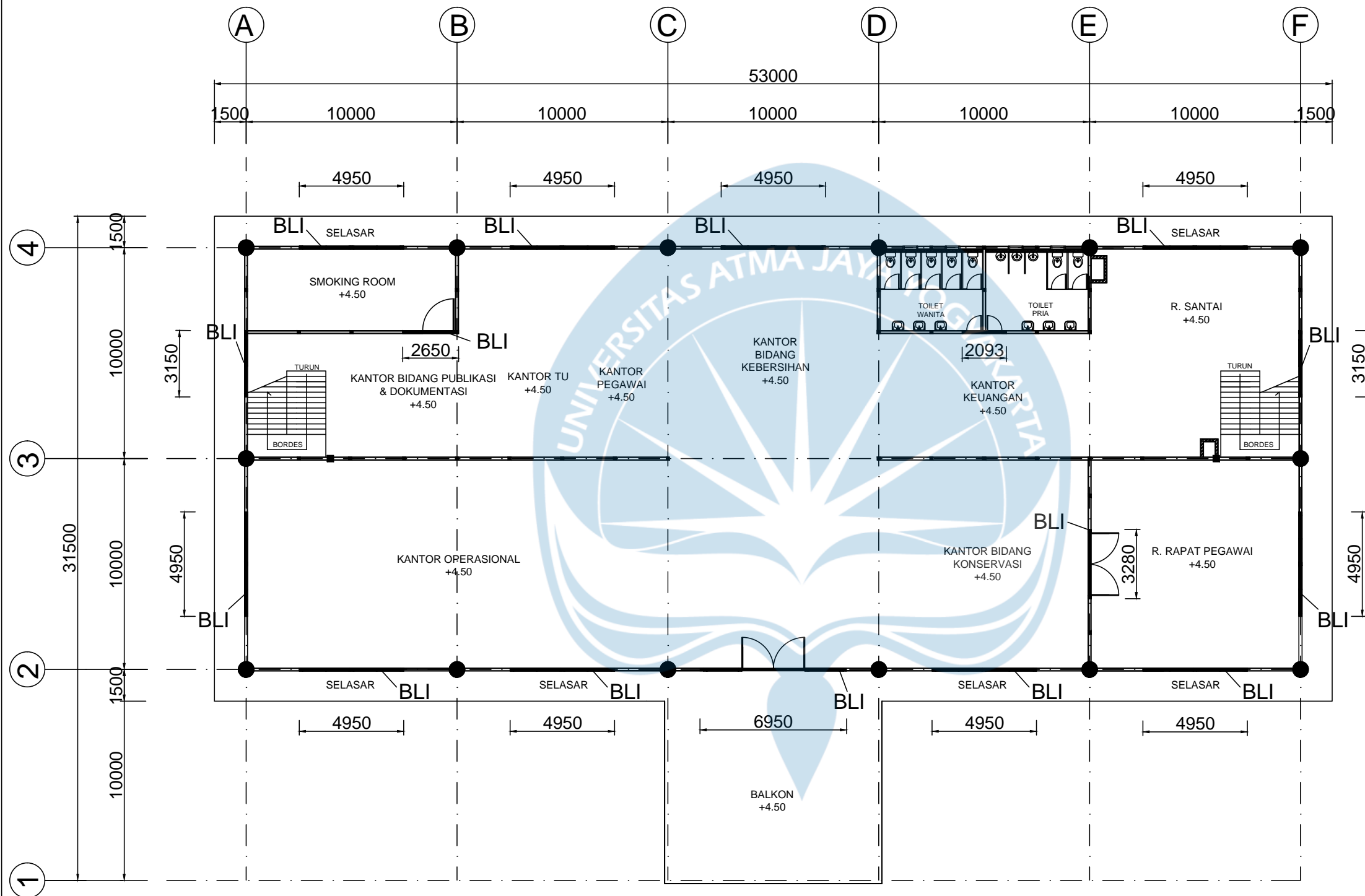

Total Panjang :
 BLI = 73,61 m

DENAH BALOK LATEI LANTAI 2
 1:100

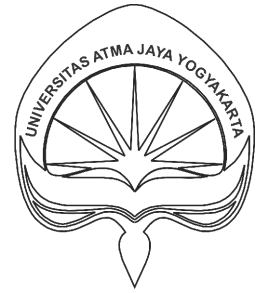

PROGRAM STUDI TEKNIK SIPIL
 FAKULTAS TEKNIK
 UNIVERSITAS ATMA JAYA
 YOGYAKARTA

SPESIFIKASI
 BAHAN : KAYU KAMPER

ANGGOTA KELOMPOK :
 SAMUEL NABABAN
 (190217720)
 JUAN PATRICK SOASA
 (190217677)
 RICHARDUS ALGA ADMAJA
 (190217656)

DOSEN PENGAJAR :
 Ir. HARYANTO YW., M.T.
 VIENTI HADSARI, S.T., M.Eng., MECRES, Ph.D.
 DIDIT GUNAWAN PRASETYO JATI, S.Kom, M.Sc.

DOSEN PEMBIMBING :
 SISWADI, S.T., M.T.

GAMBAR		SKALA
RENCANA PINTU & JENDELA LANTAI 1		1:100
KODE GAMBAR	NO GAMBAR	JML. GAMBAR
ARS	16	31

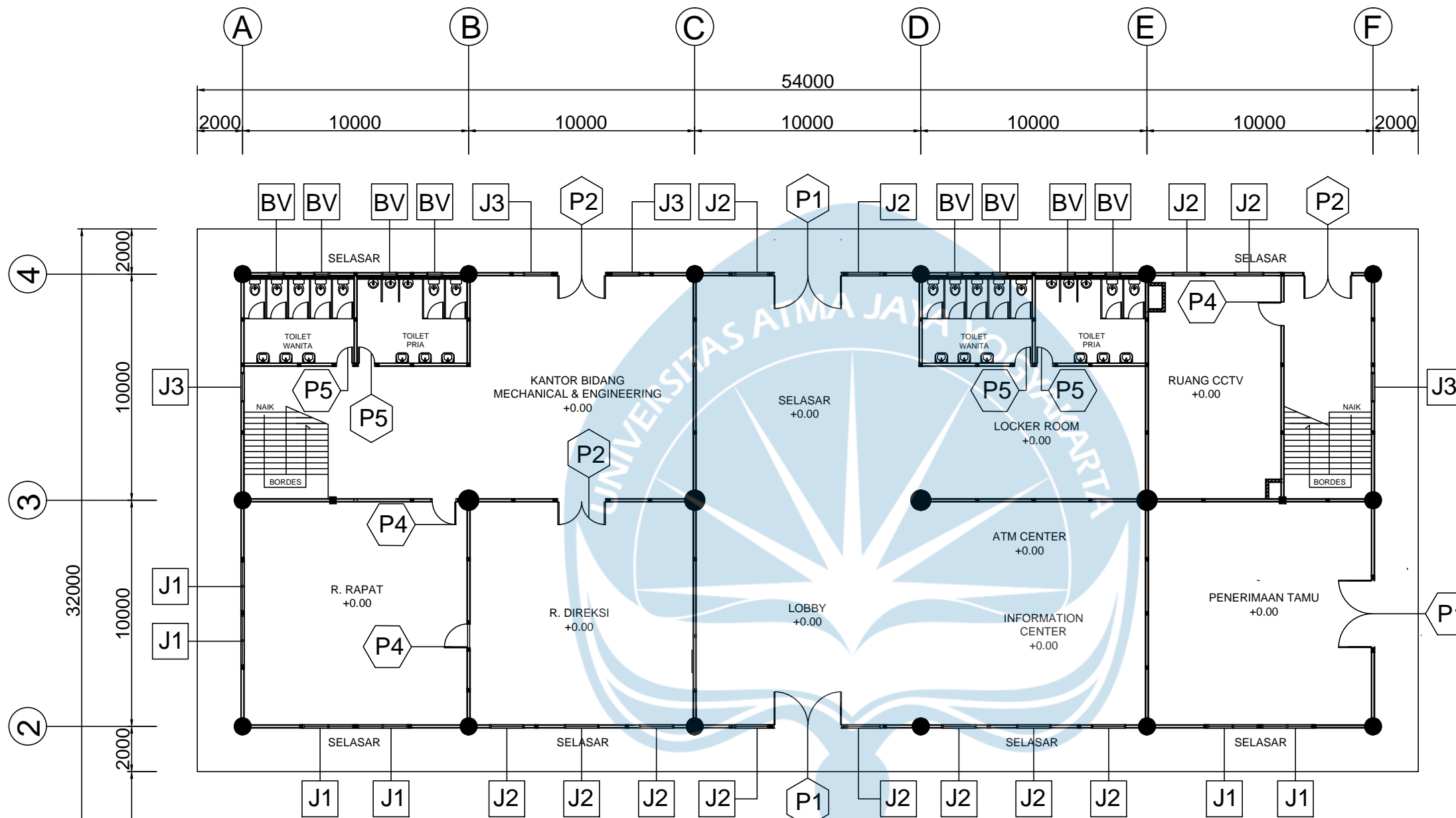

Jumlah :
 P1 = 3 unit J1 = 6 unit
 P2 = 3 unit J2 = 12 unit
 P3 = 0 unit J3 = 2 unit
 P4 = 3 unit BV = 8 unit
 P5 = 4 unit

RENCANA PINTU & JENDELA LANTAI 1
 1:100



PROGRAM STUDI TEKNIK SIPIL
FAKULTAS TEKNIK
UNIVERSITAS ATMA JAYA
YOGYAKARTA

SPESIFIKASI
BAHAN : KAYU KAMPER

ANGGOTA KELOMPOK :
SAMUEL NABABAN
(190217720)
JUAN PATRICK SOASA
(190217677)
RICHARDUS ALGA ADMAJA
(190217656)

DOSEN PENGAJAR :
Ir. HARYANTO YW., M.T.
VIENTI HADSARI, S.T., M.Eng., MECRES, Ph.D.
DIDIT GUNAWAN PRASETYO JATI, S.Kom, M.Sc.

DOSEN PEMBIMBING :
SISWADI, S.T., M.T.

GAMBAR	SKALA	
RENCANA PINTU & JENDELA LANTAI 2	1:100	
KODE GAMBAR	NO GAMBAR	JML. GAMBAR
ARS	17	31

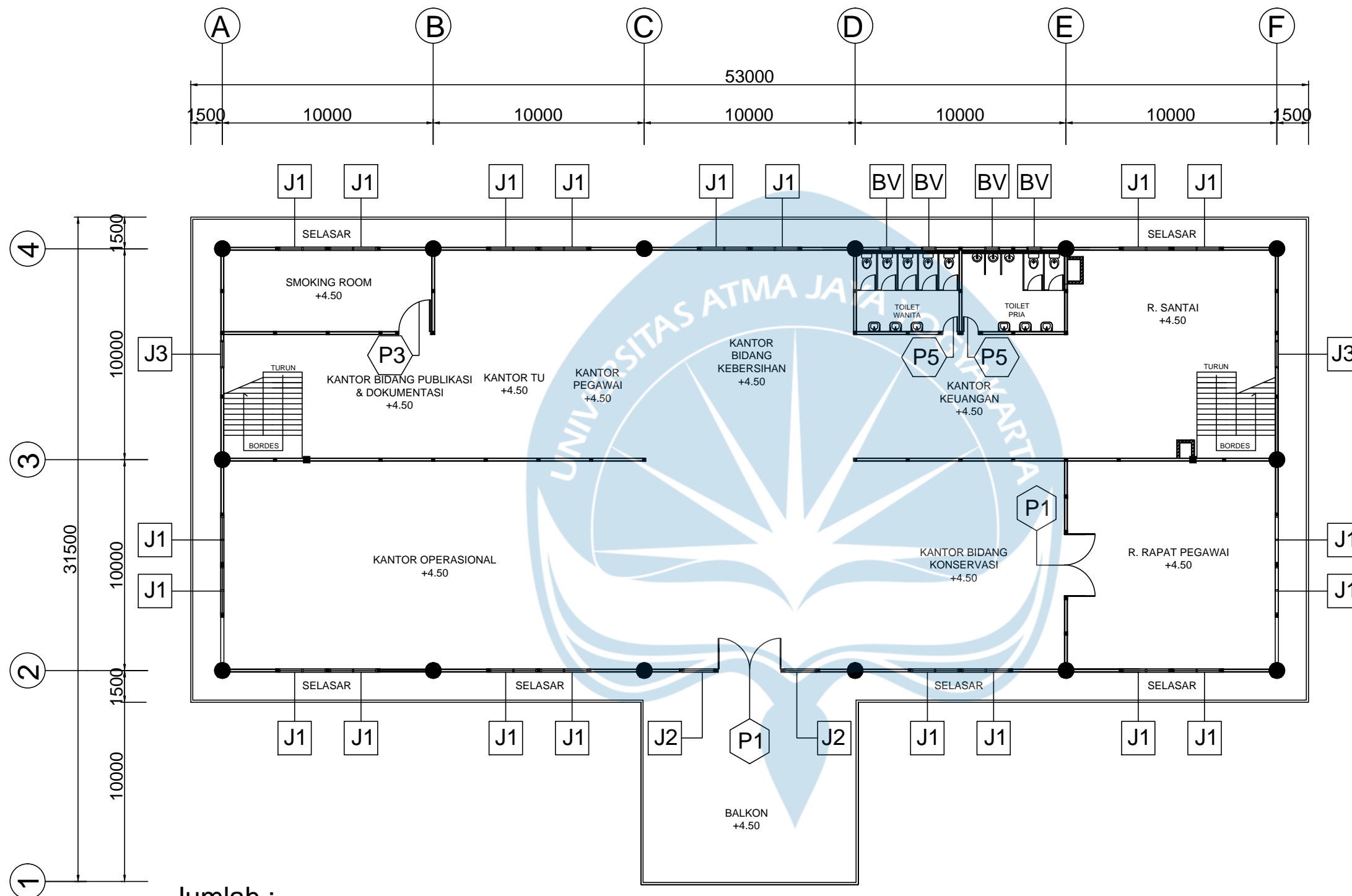

Jumlah :
 P1 = 2 unit J1 = 20 unit
 P2 = 0 unit J2 = 2 unit
 P3 = 1 unit J3 = 2 unit
 P4 = 0 unit BV = 4 unit
 P5 = 2 unit

RENCANA PINTU & JENDELA LANTAI 2
1:100

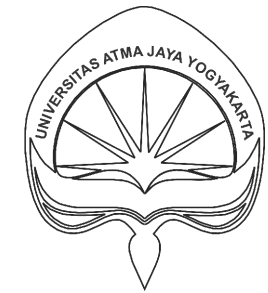

PROGRAM STUDI TEKNIK SIPIL
 FAKULTAS TEKNIK
 UNIVERSITAS ATMA JAYA
 YOGYAKARTA

SPESIFIKASI

ANGGOTA KELOMPOK :

SAMUEL NABABAN
 (190217720)
 JUAN PATRICK SOASA
 (190217677)
 RICHARDUS ALGA ADMAJA
 (190217656)

DOSEN PENGAJAR :

Ir. HARYANTO YW., M.T.
 VIENTI HADSARI, S.T., M.Eng., MECRES, Ph.D.
 DIDIT GUNAWAN PRASETYO JATI, S.Kom, M.Sc.

DOSEN PEMBIMBING :

SISWADI, S.T., M.T.

GAMBAR

SKALA

DETAIL PINTU &
 JENDELA LANTAI 1

1:20

KODE GAMBAR NO GAMBAR JML. GAMBAR

ARS 18 31

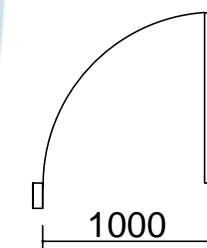
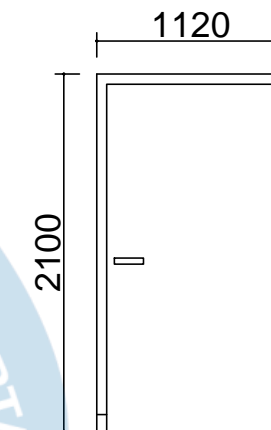
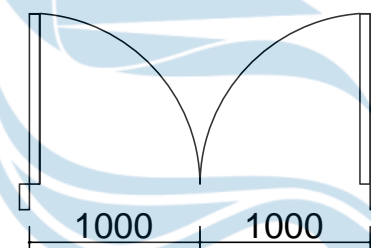
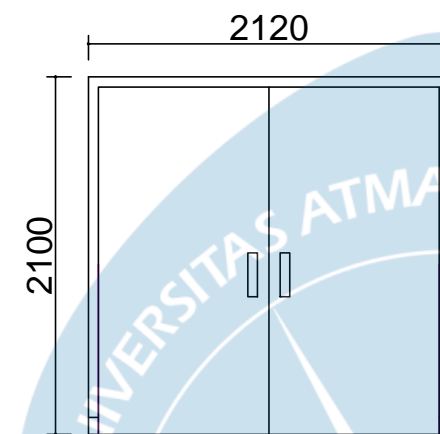
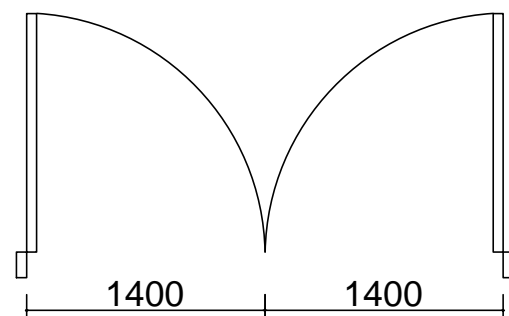
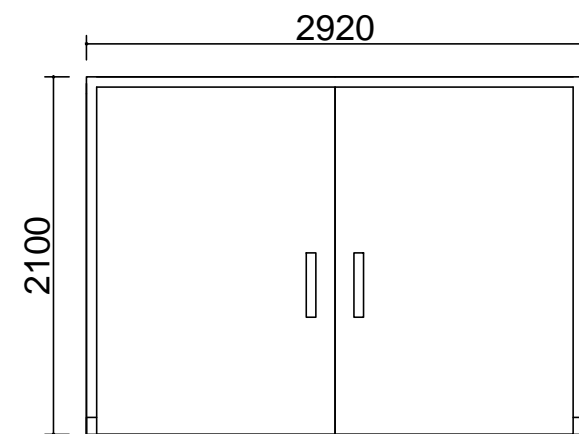

TIPE	P1	TIPE	P2	TIPE	P4
KUSEN	KAYU KAMPER 6"	KUSEN	KAYU KAMPER 6"	KUSEN	KAYU KAMPER 6"
DAUN PINTU	KAYU KAMPER t: 30 mm	DAUN PINTU	KAYU KAMPER t: 30 mm	DAUN PINTU	KAYU KAMPER t: 30 mm
DAUN JENDELA	-	DAUN JENDELA	-	DAUN JENDELA	-
KACA	-	KACA	-	KACA	-
FINISHING	MELAMIN	FINISHING	MELAMIN	FINISHING	MELAMIN
AKSESORIS	ENGSEL 5" (6 Buah)	AKSESORIS	ENGSEL 5" (6 Buah)	AKSESORIS	ENGSEL 4" (3 Buah)
	HANDLE TIPE 1 (2 Pasang)		HANDLE TIPE 1 (2 Pasang)		HANDLE TIPE 2 (1 Pasang)

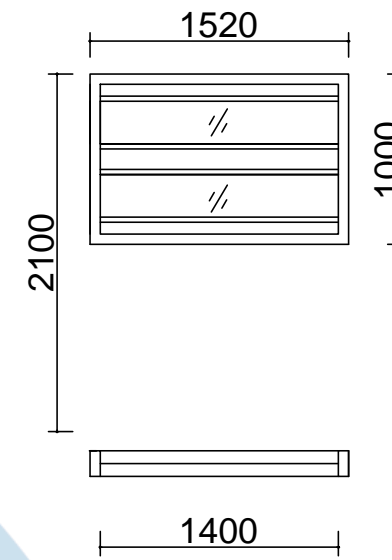
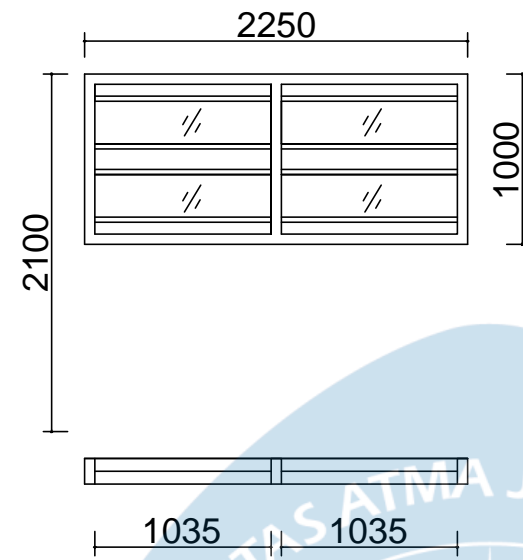
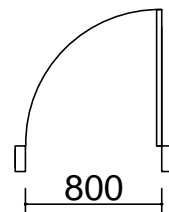
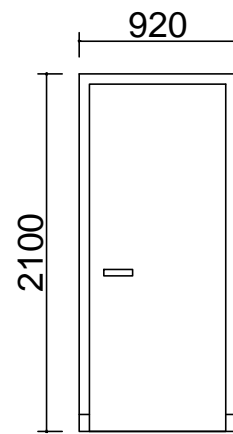

TIPE	J1
KUSEN	KAYU KAMPER 6"
DAUN PINTU	-
DAUN JENDELA	KAYU KAMPER t: 30 mm
KACA	KACA BENING t: 5 mm
FINISHING	MELAMIN
AKSESORIS	-

TIPE	J2
KUSEN	KAYU KAMPER 6"
DAUN PINTU	-
DAUN JENDELA	KAYU KAMPER t: 30 mm
KACA	KACA BENING t: 5 mm
FINISHING	MELAMIN
AKSESORIS	-

TIPE	P5
KUSEN	KAYU KAMPER 6"
DAUN PINTU	KAYU KAMPER t: 30 mm
DAUN JENDELA	-
KACA	-
FINISHING	MELAMIN
AKSESORIS	ENGSEL 4" (3 Buah)
	HANDLE TIPE 2 (1 Pasang)

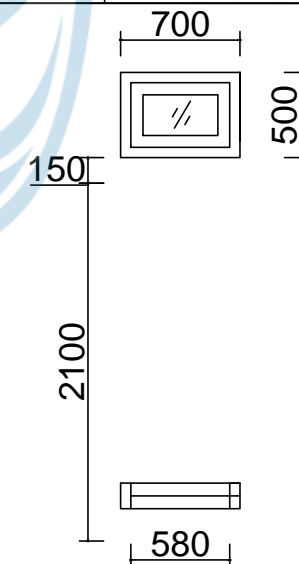
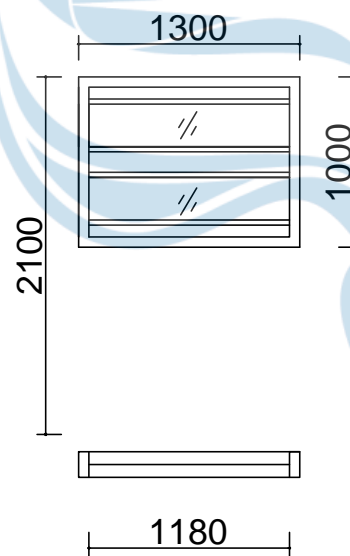

TIPE	J3
KUSEN	KAYU KAMPER 6"
DAUN PINTU	-
DAUN JENDELA	KAYU KAMPER t: 30 mm
KACA	KACA BENING t: 5 mm
FINISHING	MELAMIN
AKSESORIS	-

TIPE	BV
KUSEN	KAYU KAMPER 6"
DAUN PINTU	-
DAUN JENDELA	KAYU KAMPER t: 30 mm
KACA	KACA BENING t: 5 mm
FINISHING	MELAMIN
AKSESORIS	CASEMENTS (1 Pasang)

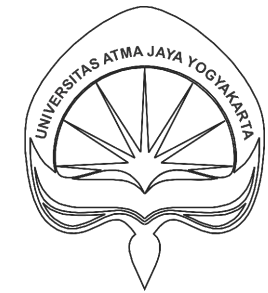

PROGRAM STUDI TEKNIK SIPIL
FAKULTAS TEKNIK
UNIVERSITAS ATMA JAYA
YOGYAKARTA

SPESIFIKASI

ANGGOTA KELOMPOK :

SAMUEL NABABAN
(190217720)
JUAN PATRICK SOASA
(190217677)
RICHARDUS ALGA ADMAJA
(190217656)

DOSEN PENGAJAR :

Ir. HARYANTO YW., M.T.
VIENTI HADSARI, S.T., M.Eng., MECRES, Ph.D.
DIDIT GUNAWAN PRASETYO JATI, S.Kom, M.Sc.

DOSEN PEMBIMBING :

SISWADI, S.T., M.T.

GAMBAR

SKALA

DETAIL PINTU &
JENDELA LANTAI 1

1:20

KODE GAMBAR NO GAMBAR JML. GAMBAR

ARS 19 31



PROGRAM STUDI TEKNIK SIPIL
 FAKULTAS TEKNIK
 UNIVERSITAS ATMA JAYA
 YOGYAKARTA

SPESIFIKASI

ANGGOTA KELOMPOK :
 SAMUEL NABABAN
 (190217720)
 JUAN PATRICK SOASA
 (190217677)
 RICHARDUS ALGA ADMAJA
 (190217656)

DOSEN PENGAJAR :
 Ir. HARYANTO YW., M.T.
 VIENTI HADSARI, S.T., M.Eng., MECRES, Ph.D.
 DIDIT GUNAWAN PRASETYO JATI, S.Kom, M.Sc.

DOSEN PEMBIMBING :
 SISWADI, S.T., M.T.

GAMBAR SKALA

DETAIL PINTU &
 JENDELA LANTAI 2 1:20

KODE GAMBAR	NO GAMBAR	JML. GAMBAR
ARS	20	31

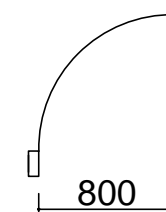
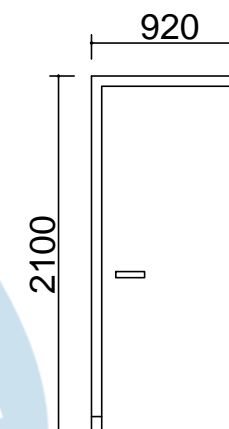
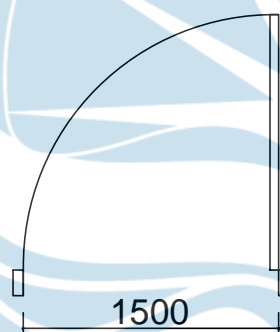
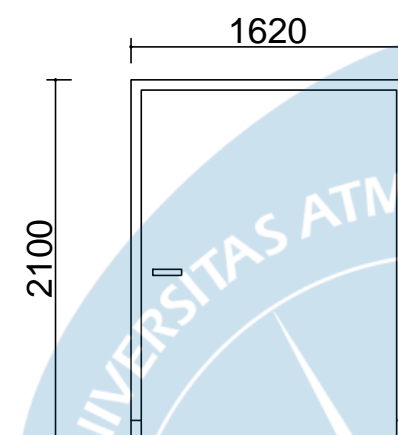
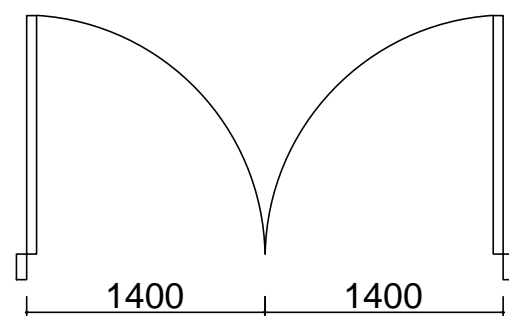
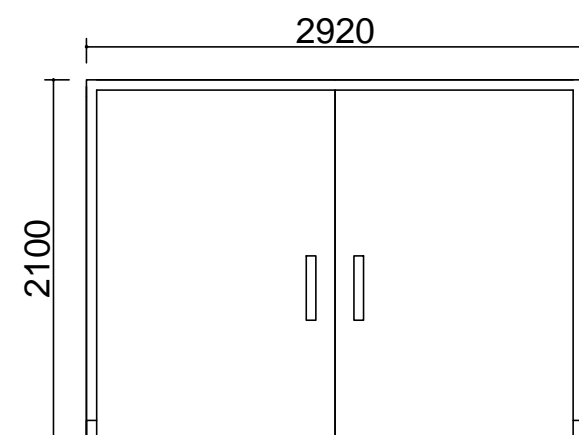

TIPE	P1	TIPE	P3	TIPE	P5
KUSEN	KAYU KAMPER 6"	KUSEN	KAYU KAMPER 6"	KUSEN	KAYU KAMPER 6"
DAUN PINTU	KAYU KAMPER t: 30 mm	DAUN PINTU	KAYU KAMPER t: 30 mm	DAUN PINTU	KAYU KAMPER t: 30 mm
DAUN JENDELA	-	DAUN JENDELA	-	DAUN JENDELA	-
KACA	-	KACA	-	KACA	-
FINISHING	MELAMIN	FINISHING	MELAMIN	FINISHING	MELAMIN
AKSESORIS	ENGSEL 5" (6 Buah)	AKSESORIS	ENGSEL 5" (3 Buah)	AKSESORIS	ENGSEL 4" (3 Buah)
	HANDLE TIPE 1 (2 Pasang)		HANDLE TIPE 2 (1 Pasang)		HANDLE TIPE 2 (1 Pasang)



PROGRAM STUDI TEKNIK SIPIL
FAKULTAS TEKNIK
UNIVERSITAS ATMA JAYA
YOGYAKARTA

SPESIFIKASI

ANGGOTA KELOMPOK :

SAMUEL NABABAN
(190217720)
JUAN PATRICK SOASA
(190217677)
RICHARDUS ALGA ADMAJA
(190217656)

DOSEN PENGAJAR :

Ir. HARYANTO YW., M.T.
VIENTI HADSARI, S.T., M.Eng., MECRES, Ph.D.
DIDIT GUNAWAN PRASETYO JATI, S.Kom, M.Sc.

DOSEN PEMBIMBING :

SISWADI, S.T., M.T.

GAMBAR

SKALA

DETAIL PINTU &
JENDELA LANTAI 2

1:20

KODE GAMBAR	NO GAMBAR	JML. GAMBAR
-------------	-----------	-------------

ARS	21	31
-----	----	----

TIPE	J1	TIPE	J2
KUSEN	KAYU KAMPER 6"	KUSEN	KAYU KAMPER 6"
DAUN PINTU	-	DAUN PINTU	-
DAUN JENDELA	KAYU KAMPER t: 30 mm	DAUN JENDELA	KAYU KAMPER t: 30 mm
KACA	KACA BENING t: 5 mm	KACA	KACA BENING t: 5 mm
FINISHING	MELAMIN	FINISHING	MELAMIN
AKSESORIS	-	AKSESORIS	-
TIPE	J3	TIPE	BV
KUSEN	KAYU KAMPER 6"	KUSEN	KAYU KAMPER 6"
DAUN PINTU	-	DAUN PINTU	-
DAUN JENDELA	KAYU KAMPER t: 30 mm	DAUN JENDELA	KAYU KAMPER t: 30 mm
KACA	KACA BENING t: 5 mm	KACA	KACA BENING t: 5 mm
FINISHING	MELAMIN	FINISHING	MELAMIN
AKSESORIS	-	AKSESORIS	CASEMENTS (1 Pasang)



PROGRAM STUDI TEKNIK SIPIL
 FAKULTAS TEKNIK
 UNIVERSITAS ATMA JAYA
 YOGYAKARTA

SPESIFIKASI

ANGGOTA KELOMPOK :

SAMUEL NABABAN
 (190217720)
 JUAN PATRICK SOASA
 (190217677)
 RICHARDUS ALGA ADMAJA
 (190217656)

DOSEN PENGAJAR :

Ir. HARYANTO YW., M.T.
 VIENTI HADSARI, S.T., M.Eng., MECRES, Ph.D.
 DIDIT GUNAWAN PRASETYO JATI, S.Kom, M.Sc.

DOSEN PEMBIMBING :

SISWADI, S.T., M.T.

GAMBAR

SKALA

RENCANA PLAFON
 LANTAI 1

1:100

KODE GAMBAR NO GAMBAR JML. GAMBAR

ARS 22 31

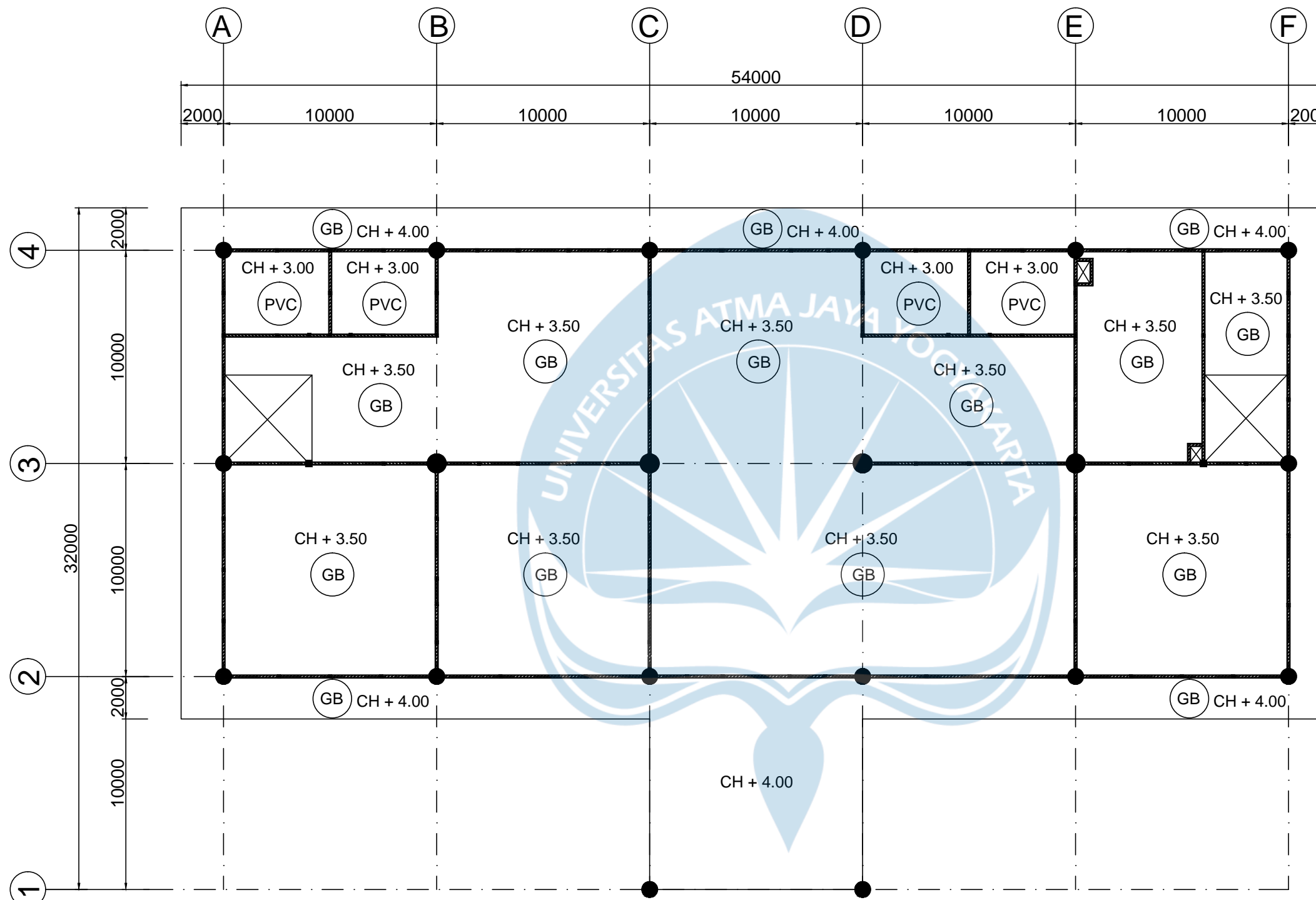

LEGENDA :

	= GYPSUM BOARD FINISH CAT
	= PLAFON PVC

RENCANA PLAFON LANTAI 1

1:100



PROGRAM STUDI TEKNIK SIPIL
 FAKULTAS TEKNIK
 UNIVERSITAS ATMA JAYA
 YOGYAKARTA

SPESIFIKASI

ANGGOTA KELOMPOK :
 SAMUEL NABABAN
 (190217720)
 JUAN PATRICK SOASA
 (190217677)
 RICHARDUS ALGA ADMAJA
 (190217656)

DOSEN PENGAJAR :
 Ir. HARYANTO YW., M.T.
 VIENTI HADSARI, S.T., M.Eng., MECRES, Ph.D.
 DIDIT GUNAWAN PRASETYO JATI, S.Kom, M.Sc.

DOSEN PEMBIMBING :
 SISWADI, S.T., M.T.

GAMBAR	SKALA
--------	-------

RENCANA PLAFON LANTAI 2	1:100
-------------------------	-------

KODE GAMBAR	NO GAMBAR	JML. GAMBAR
ARS	23	31

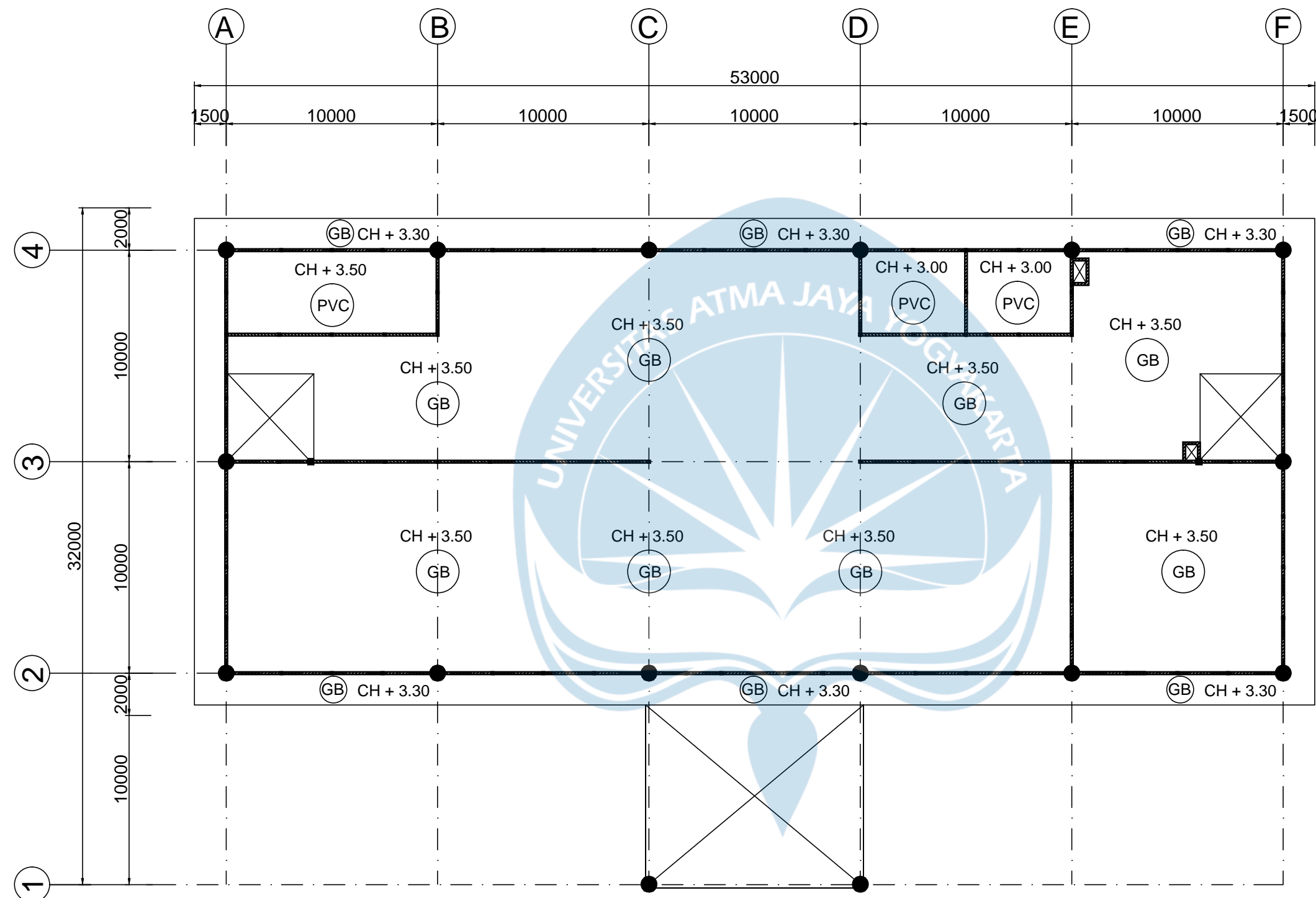

LEGENDA :

⊙ GB	= GYPSUM BOARD FINISH CAT
⊙ PVC	= PLAFON PVC

RENCANA PLAFON LANTAI 2
 1:100



PROGRAM STUDI TEKNIK SIPIL
 FAKULTAS TEKNIK
 UNIVERSITAS ATMA JAYA
 YOGYAKARTA

SPESIFIKASI

ANGGOTA KELOMPOK :

SAMUEL NABABAN
 (190217720)
 JUAN PATRICK SOASA
 (190217677)
 RICHARDUS ALGA ADMAJA
 (190217656)

DOSEN PENGAJAR :

Ir. HARYANTO YW., M.T.
 VIENTI HADSARI, S.T., M.Eng., MECRES, Ph.D.
 DIDIT GUNAWAN PRASETYO JATI, S.Kom, M.Sc.

DOSEN PEMBIMBING :

SISWADI, S.T., M.T.

GAMBAR

SKALA

DETAIL PLAFON

1:50

KODE GAMBAR NO GAMBAR JML. GAMBAR

ARS 24 31

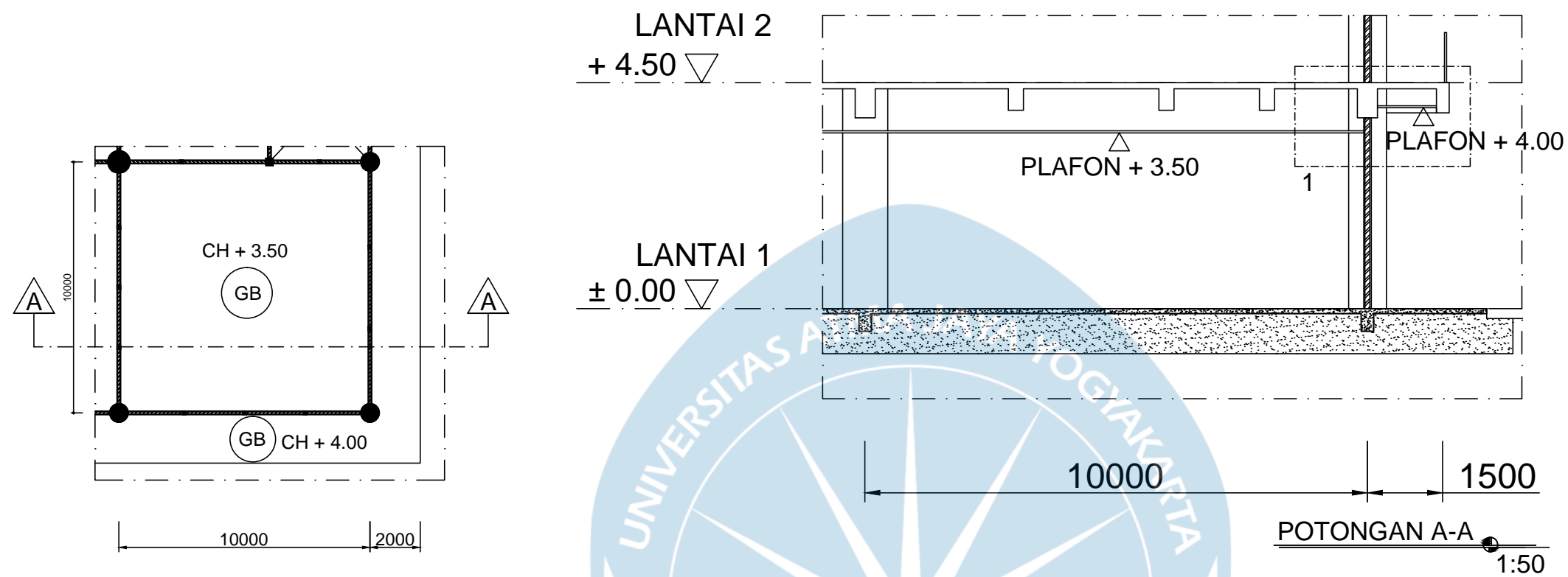

DENAH PLAFON A1
 1:100

HANGER RODS PLAFON

HOLLOW 40 X 40

GYPSUM 9 mm

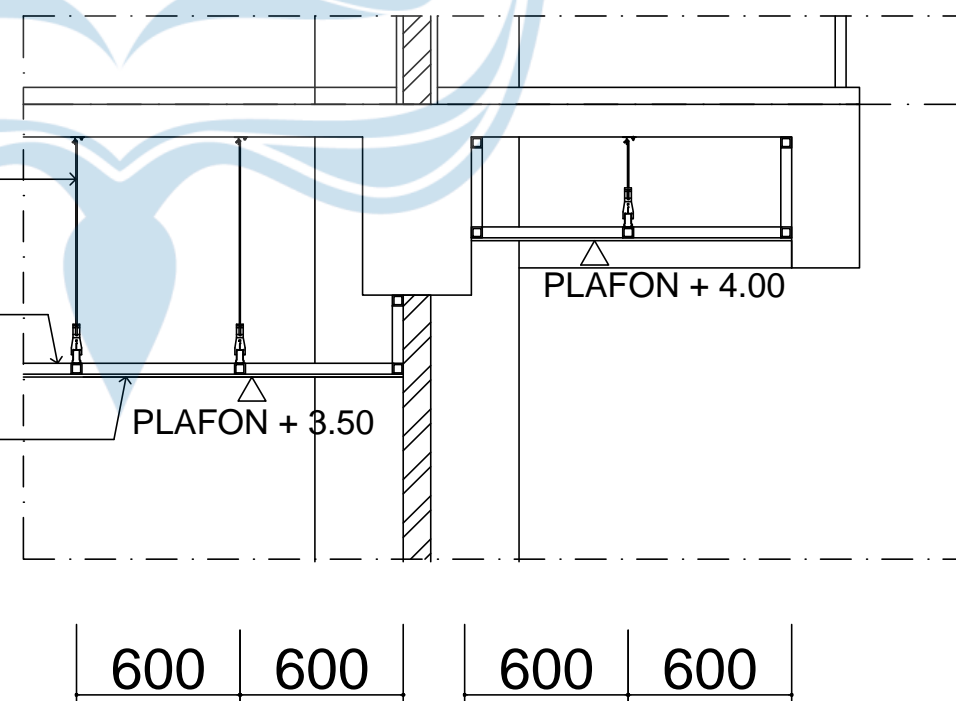

DETAIL 1
 1:12,5

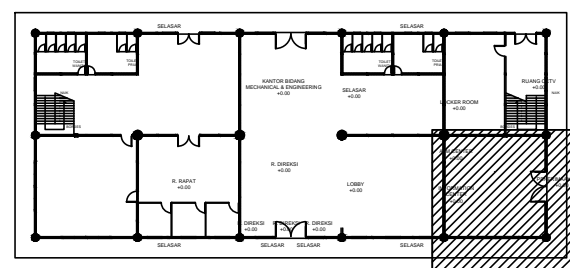

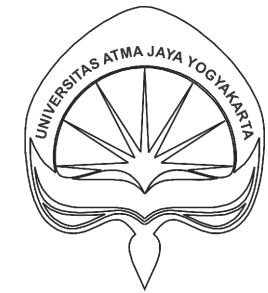

PROGRAM STUDI TEKNIK SIPIL
 FAKULTAS TEKNIK
 UNIVERSITAS ATMA JAYA
 YOGYAKARTA

SPESIFIKASI

HOLLOW 40 x 40 , FINISHING CAT

ANGGOTA KELOMPOK :

SAMUEL NABABAN
 (190217720)
 JUAN PATRICK SOASA
 (190217677)
 RICHARDUS ALGA ADMAJA
 (190217656)

DOSEN PENGAJAR :

Ir. HARYANTO YW., M.T.
 VIENTI HADSARI, S.T., M.Eng., MECRES, Ph.D.
 DIDIT GUNAWAN PRASETYO JATI, S.Kom, M.Sc.

DOSEN PEMBIMBING :

SISWADI, S.T., M.T.

GAMBAR

SKALA

MODUL RAILING
 TANGGA

1:15

KODE GAMBAR NO GAMBAR JML. GAMBAR

ARS 25 31

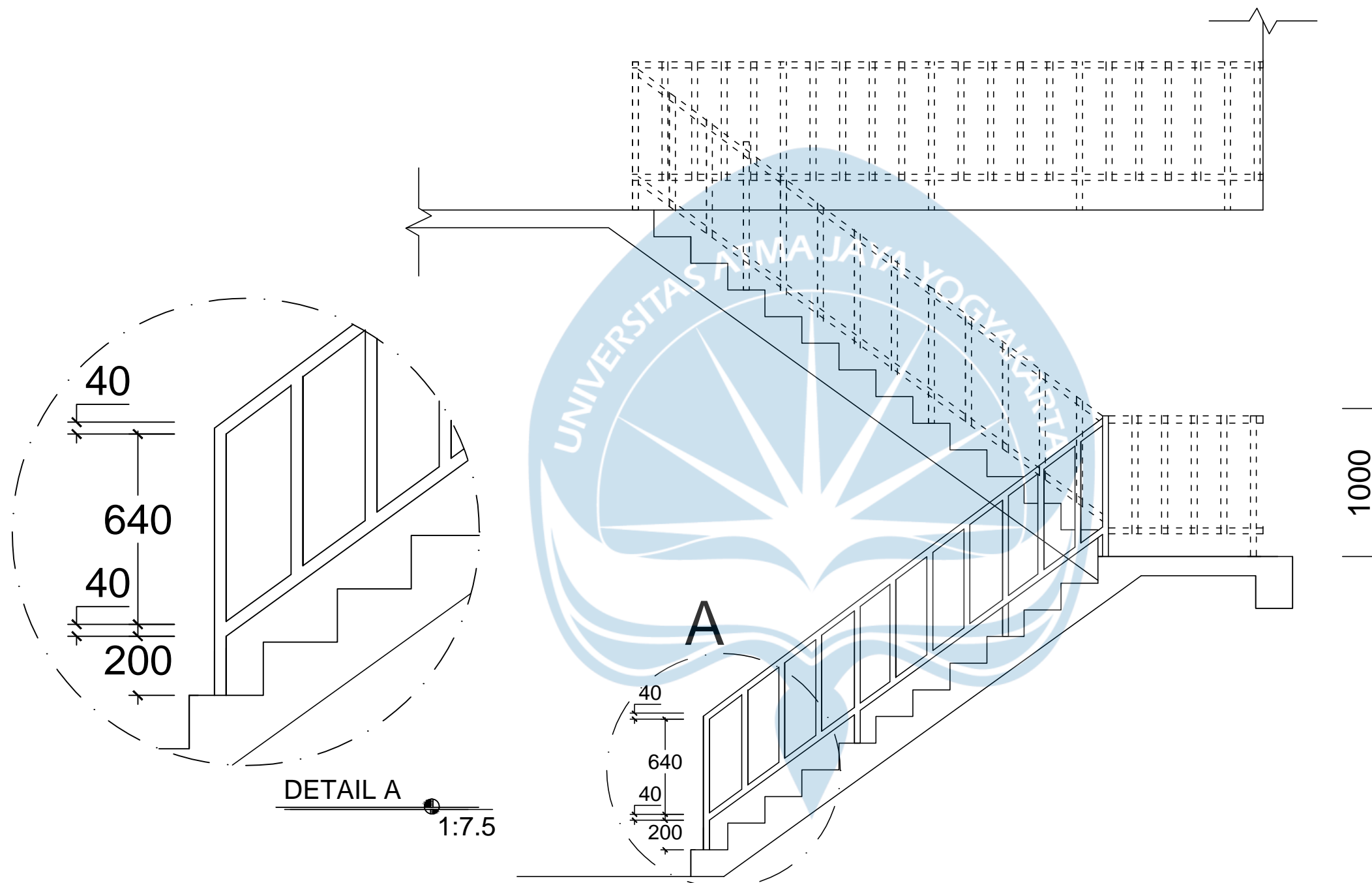

DETAIL A 1:7.5

MODUL RAILING TANGGA 1:15



PROGRAM STUDI TEKNIK SIPIL
 FAKULTAS TEKNIK
 UNIVERSITAS ATMA JAYA
 YOGYAKARTA

SPESIFIKASI

HOLLOW 40 x40 , FINISHING CAT

ANGGOTA KELOMPOK :

SAMUEL NABABAN
 (190217720)
 JUAN PATRICK SOASA
 (190217677)
 RICHARDUS ALGA ADMAJA
 (190217656)

DOSEN PENGAJAR :

Ir. HARYANTO YW., M.T.
 VIENTI HADSARI, S.T., M.Eng., MECRES, Ph.D.
 DIDIT GUNAWAN PRASETYO JATI, S.Kom, M.Sc.

DOSEN PEMBIMBING :

SISWADI, S.T., M.T.

GAMBAR

SKALA

MODUL RAILING
 BALKON & SELASAR
 LANTAI 2

1:15

KODE GAMBAR NO GAMBAR JML. GAMBAR

ARS

26

31

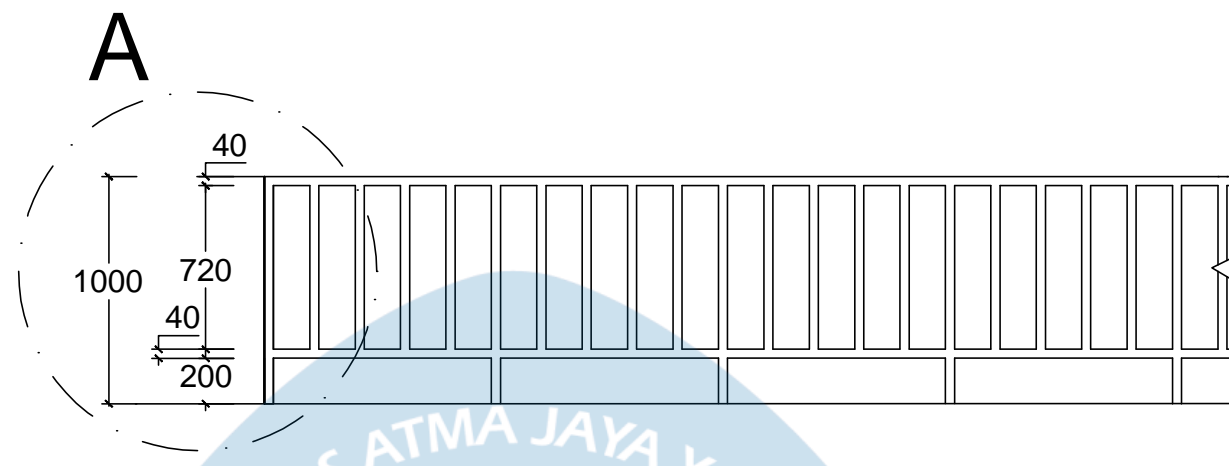

MODUL RAILING BALKON & SELASAR LANTAI 2

1:15

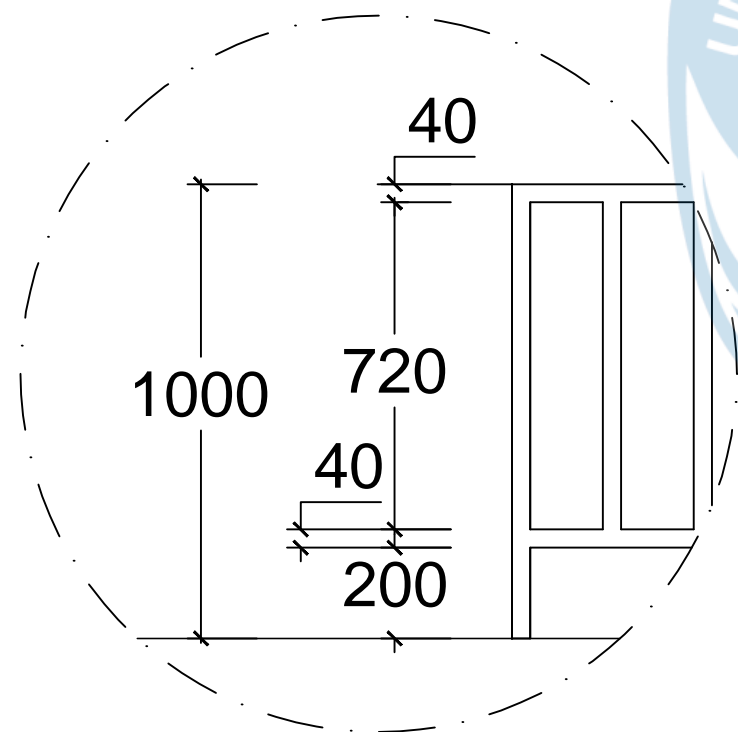

DETAIL A

1:7.5



PROGRAM STUDI TEKNIK SIPIL
 FAKULTAS TEKNIK
 UNIVERSITAS ATMA JAYA
 YOGYAKARTA

SPESIFIKASI

ANGGOTA KELOMPOK :
 SAMUEL NABABAN
 (190217720)
 JUAN PATRICK SOASA
 (190217677)
 RICHARDUS ALGA ADMAJA
 (190217656)

DOSEN PENGAJAR :
 Ir. HARYANTO YW., M.T.
 VIENTI HADSARI, S.T., M.Eng., MECRES, Ph.D.
 DIDIT GUNAWAN PRASETYO JATI, S.Kom, M.Sc.

DOSEN PEMBIMBING :
 SISWADI, S.T., M.T.

GAMBAR	SKALA
--------	-------

DENAH TOILET	1:20
--------------	------

KODE GAMBAR	NO GAMBAR	JML. GAMBAR
ARS	27	31

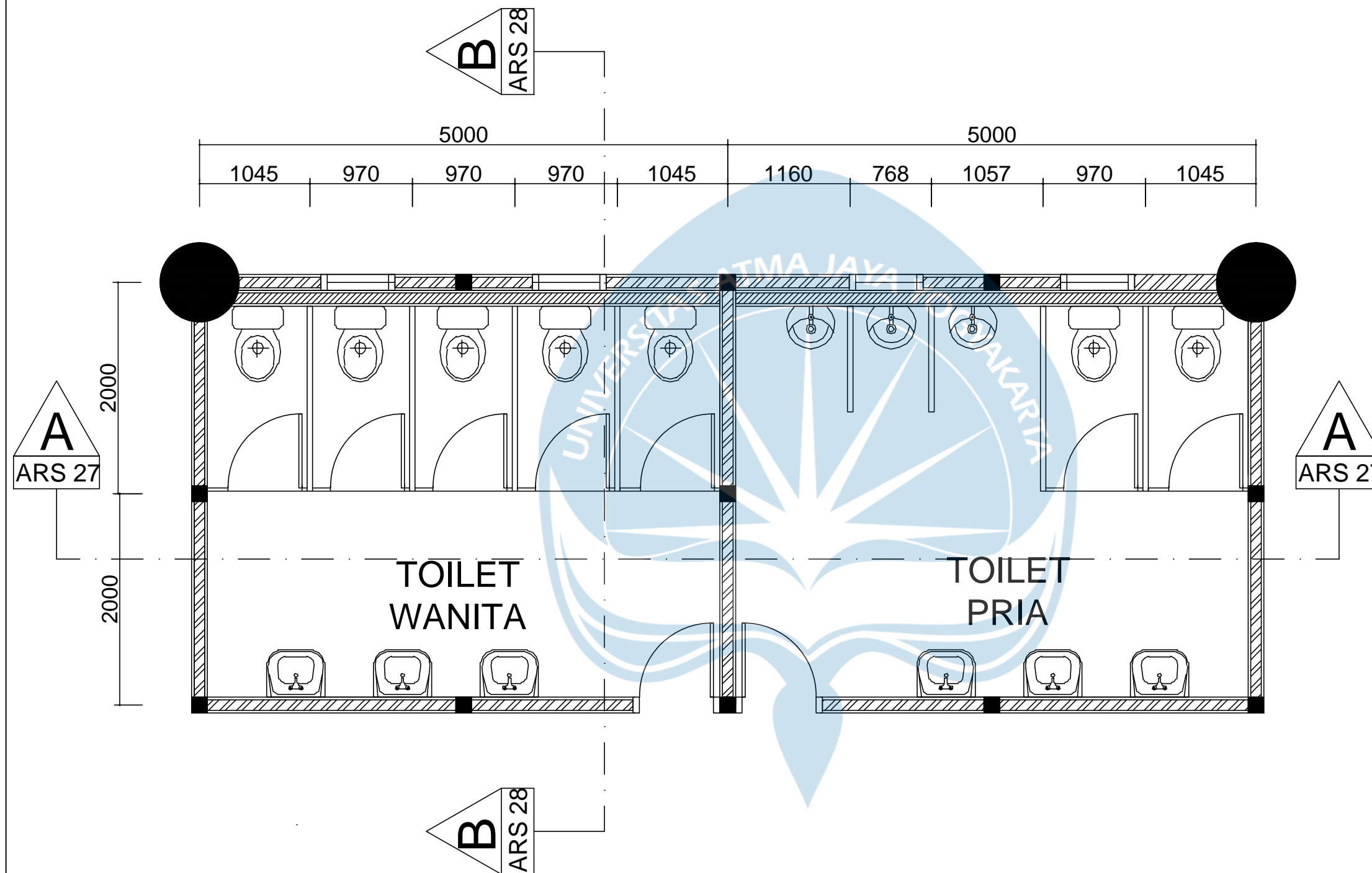

DENAH TOILET
 1:20



PROGRAM STUDI TEKNIK SIPIL
FAKULTAS TEKNIK
UNIVERSITAS ATMA JAYA
YOGYAKARTA

SPESIFIKASI

ANGGOTA KELOMPOK :

SAMUEL NABABAN
(190217720)
JUAN PATRICK SOASA
(190217677)
RICHARDUS ALGA ADMAJA
(190217656)

DOSEN PENGAJAR :

Ir. HARYANTO YW., M.T.
VIENTI HADSARI, S.T., M.Eng., MECRES, Ph.D.
DIDIT GUNAWAN PRASETYO JATI, S.Kom, M.Sc.

DOSEN PEMBIMBING :

SISWADI, S.T., M.T.

GAMBAR

SKALA

POTONGAN A-A
TOILET

1:20

KODE GAMBAR NO GAMBAR JML. GAMBAR

ARS

28

31

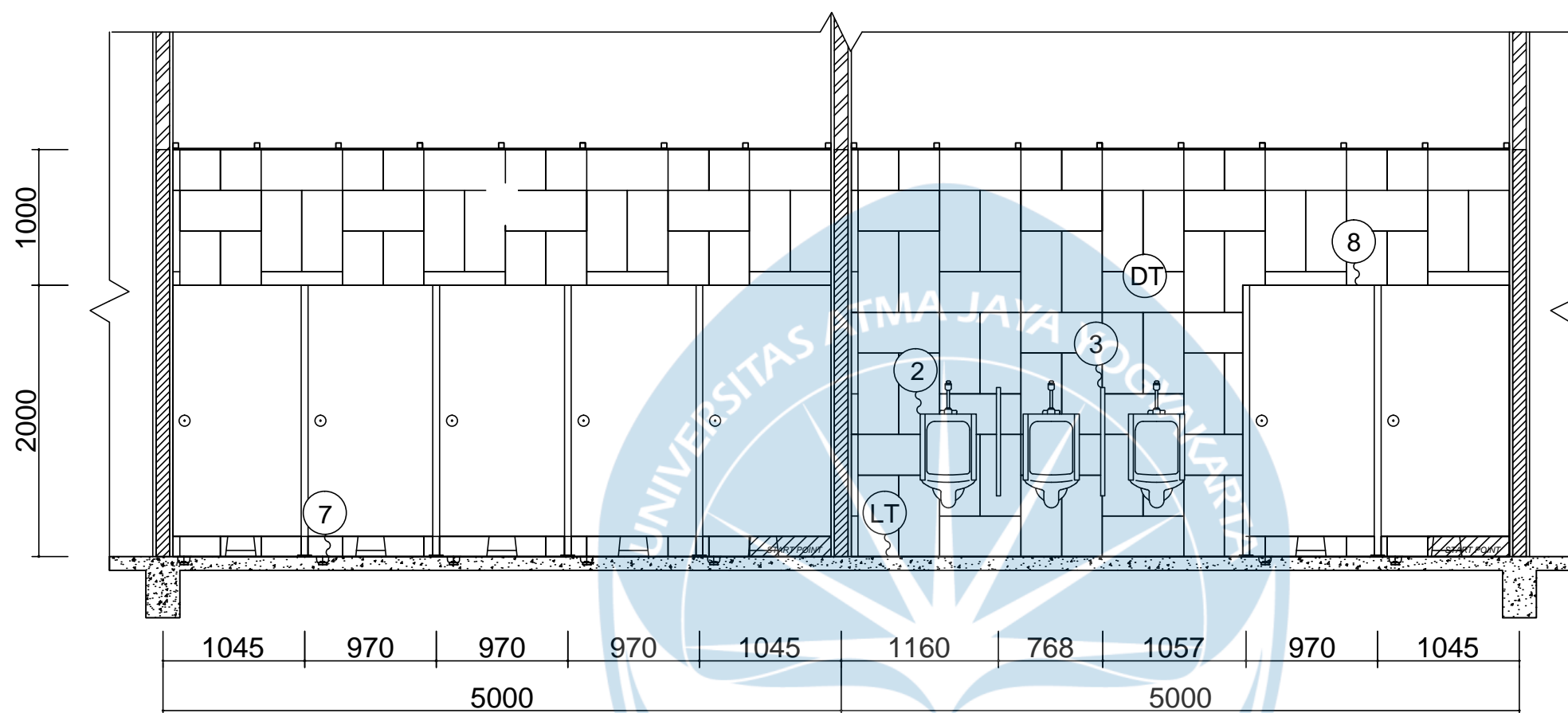

POTONGAN A-A TOILET

1:20

LEGENDA SANITAIR :

	NAMA ITEM	JUMLAH	KETERANGAN
①	CLOSET DUDUK	7 UNIT	TOTO CW638J
②	URINOIR	3 UNIT	TOTO CW70418
③	PARTISI URINOIR	2 UNIT	TOTO A100
④	CERMIN t = 5 mm	4.8 M ²	EX. ASAHI
⑤	WASTAFEL	6 UNIT	VANITORY MONACO EX. AMSTAD
⑥	JET WASHER	7 UNIT	AMERICAN STANDARD FFTP404
⑦	FLOOR DRAIN	7 UNIT	TOTO STAINLESS
⑧	PARTISI TOILET	34.146 M ²	SEKAT PVC t = 0.5 mm

LEGENDA MATERIAL :

ⓓ	KERAMIK 30 x 60 cm (POLISHED)
ⓓ	KERAMIK 30 x 30 cm (UNPOLISHED) ELV +4.50



PROGRAM STUDI TEKNIK SIPIL
 FAKULTAS TEKNIK
 UNIVERSITAS ATMA JAYA
 YOGYAKARTA

SPESIFIKASI

ANGGOTA KELOMPOK :

SAMUEL NABABAN
 (190217720)
 JUAN PATRICK SOASA
 (190217677)
 RICHARDUS ALGA ADMAJA
 (190217656)

DOSEN PENGAJAR :

Ir. HARYANTO YW., M.T.
 VIENTI HADSARI, S.T., M.Eng., MECRES, Ph.D.
 DIDIT GUNAWAN PRASETYO JATI, S.Kom, M.Sc.

DOSEN PEMBIMBING :

SISWADI, S.T., M.T.

GAMBAR

SKALA

POTONGAN B-B
 TOILET

1:20

KODE GAMBAR NO GAMBAR JML. GAMBAR

ARS 29 31

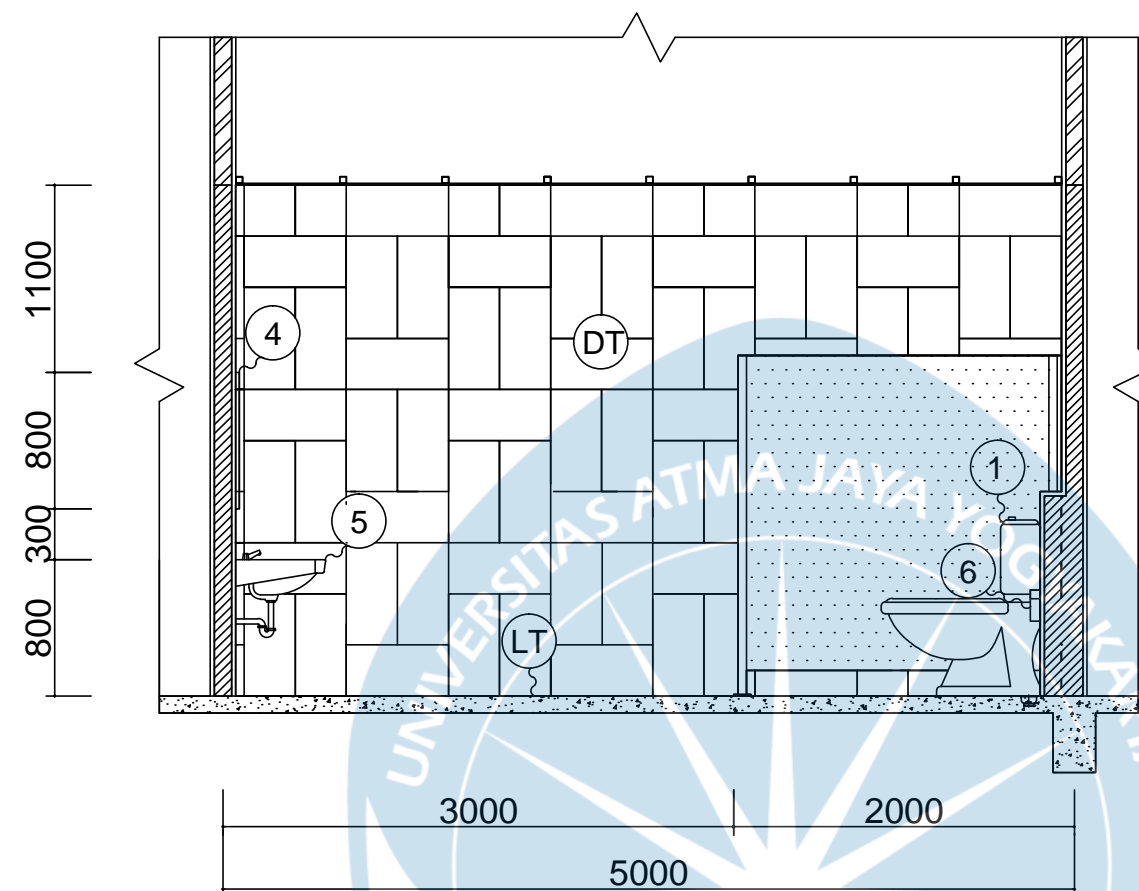

POTONGAN B-B TOILET

1:20

LEGENDA SANITAIR :

	NAMA ITEM	JUMLAH	KETERANGAN
①	CLOSET DUDUK	7 UNIT	TOTO CW638J
②	URINOIR	3 UNIT	TOTO CW70418
③	PARTISI URINOIR	2 UNIT	TOTO A100
④	CERMIN t = 5 mm	4.8 M ²	EX. ASAHI
⑤	WASTAFEL	6 UNIT	VANITORY MONACO EX. AMSTAD
⑥	JET WASHER	7 UNIT	AMERICAN STANDARD FFTP404
⑦	FLOOR DRAIN	7 UNIT	TOTO STAINLESS
⑧	PARTISI TOILET	34.146 M ²	SEKAT PVC t = 0.5 mm

LEGENDA MATERIAL :

ⓓ	KERAMIK 30 x 60 cm (POLISHED)
ⓓ	KERAMIK 30 x 30 cm (UNPOLISHED) ELV +4.50

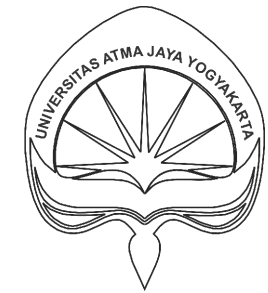

PROGRAM STUDI TEKNIK SIPIL
 FAKULTAS TEKNIK
 UNIVERSITAS ATMA JAYA
 YOGYAKARTA

SPESIFIKASI

ANGGOTA KELOMPOK :

SAMUEL NABABAN
 (190217720)
 JUAN PATRICK SOASA
 (190217677)
 RICHARDUS ALGA ADMAJA
 (190217656)

DOSEN PENGAJAR :

Ir. HARYANTO YW., M.T.
 VIENTI HADSARI, S.T., M.Eng., MECRES, Ph.D.
 DIDIT GUNAWAN PRASETYO JATI, S.Kom, M.Sc.

DOSEN PEMBIMBING :

SISWADI, S.T., M.T.

GAMBAR

SKALA

RENCANA POLA
 LANTAI 1

1:100

KODE GAMBAR NO GAMBAR JML. GAMBAR

ARS 30 31

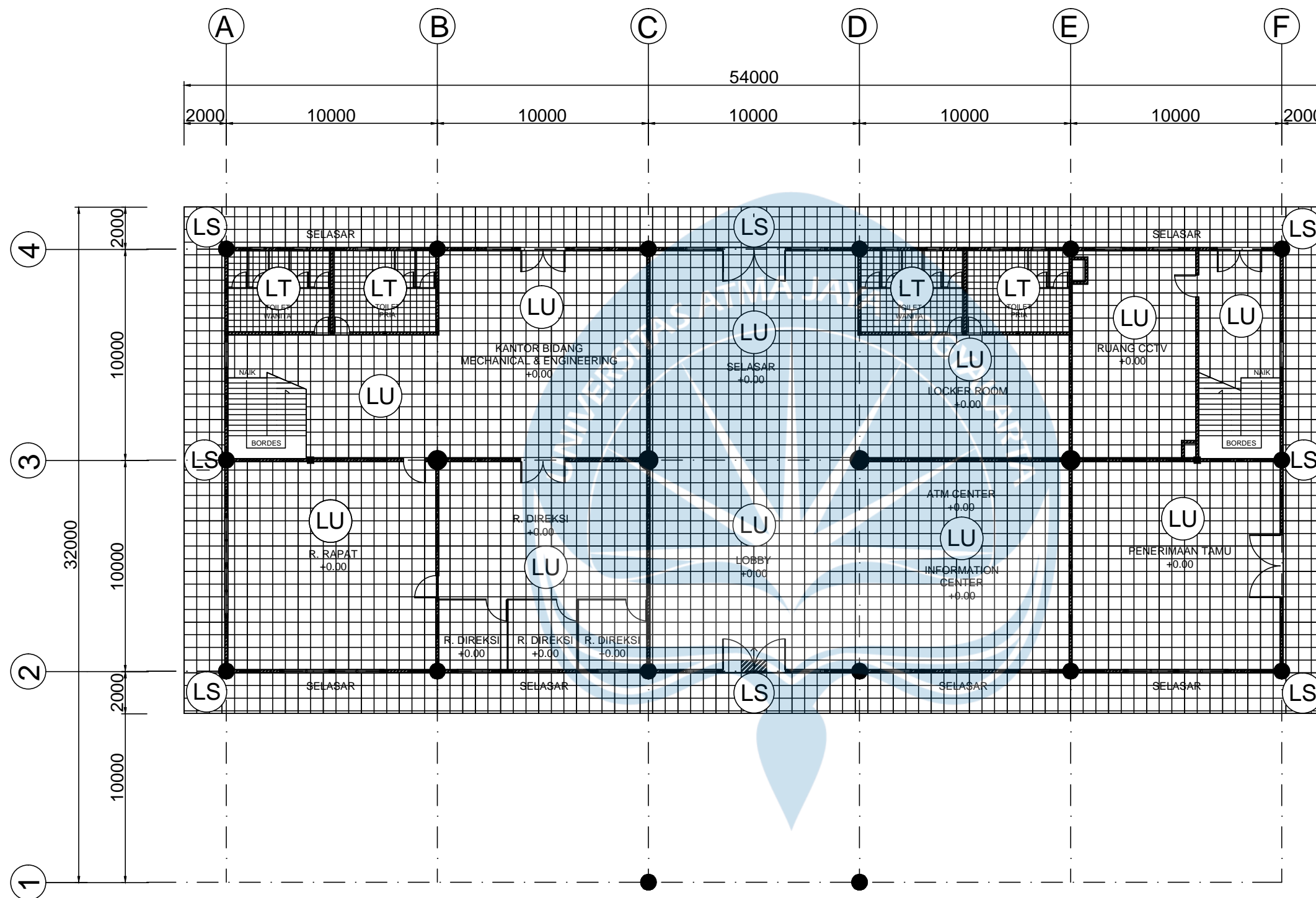

LEGENDA :

(LU)	= KERAMIK 60 x 60 cm (POLISHED) ELV +4.50
(LS)	= KERAMIK 60 x 60 cm (UNPOLISHED) ELV +4.50
(LT)	= KERAMIK 30 x 30 cm (ELV +4.50)

RENCANA POLA LANTAI 1
 1:100



PROGRAM STUDI TEKNIK SIPIL
 FAKULTAS TEKNIK
 UNIVERSITAS ATMA JAYA
 YOGYAKARTA

SPESIFIKASI

ANGGOTA KELOMPOK :

SAMUEL NABABAN
 (190217720)
 JUAN PATRICK SOASA
 (190217677)
 RICHARDUS ALGA ADMAJA
 (190217656)

DOSEN PENGAJAR :

Ir. HARYANTO YW., M.T.
 VIENTI HADSARI, S.T., M.Eng., MECRES, Ph.D.
 DIDIT GUNAWAN PRASETYO JATI, S.Kom, M.Sc.

DOSEN PEMBIMBING :

SISWADI, S.T., M.T.

GAMBAR

SKALA

RENCANA POLA
 LANTAI 2

1:100

KODE GAMBAR NO GAMBAR JML. GAMBAR

ARS 31 31

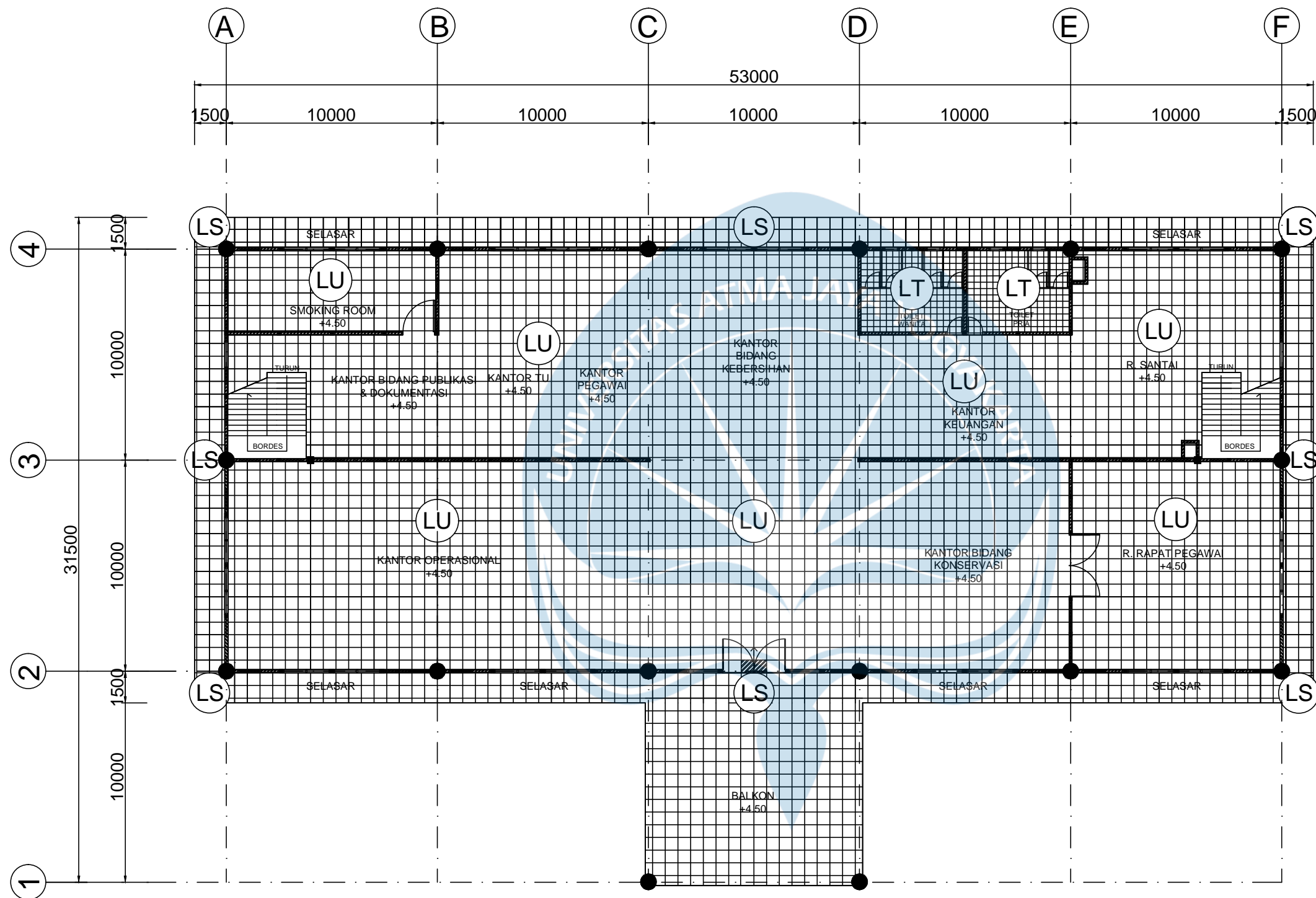

LEGENDA :

(LU)	= KERAMIK 60 x 60 cm (POLISHED) ELV +4.50
(LS)	= KERAMIK 60 x 60 cm (UNPOLISHED) ELV +4.50
(LT)	= KERAMIK 30 x 30 cm (ELV +4.50)

RENCANA POLA LANTAI 2
 1:100

Lampiran B.3. Gambar Elektrikal & Pemipaan

DAFTAR GAMBAR ELEKTRIKAL & PEMIPAAN GEDUNG PENGELOLA TAMAN REKREASI SAMARINDA

NO	KODE	NO. GAMBAR	NAMA GAMBAR	SKALA
1	EP	01	DAFTAR GAMBAR ELEKTRIKAL & PEMIPAAN	1:100
2	EP	02	DENAH INSTALASI AIR BERSIH LANTAI 1	1:100
3	EP	03	DENAH INSTALASI AIR BERSIH LANTAI 2	1:100
4	EP	04	DENAH INSTALASI AIR KOTOR LANTAI 1	1:100
5	EP	05	DENAH INSTALASI AIR KOTOR LANTAI 2	1:100
6	EP	06	DENAH INSTALASI AIR BEKAS LANTAI 1	1:100
7	EP	07	DENAH INSTALASI AIR BEKAS LANTAI 2	1:100
8	EP	08	DENAH INSTALASI AIR HUJAN LANTAI 1	1:100
9	EP	09	DENAH INSTALASI AIR HUJAN LANTAI 2	1:100
10	EP	10	DENAH INSTALASI PENERANGAN LANTAI 1	1:100
11	EP	11	DENAH INSTALASI PENERANGAN LANTAI 2	1:100
12	EP	12	DENAH INSTALASI CCTV LANTAI 1	1:100
13	EP	13	DENAH INSTALASI CCTV LANTAI 2	1:100
14	EP	14	DENAH INSTALASI WIFI LANTAI 1	1:100
15	EP	15	DENAH INSTALASI WIFI LANTAI 2	1:100

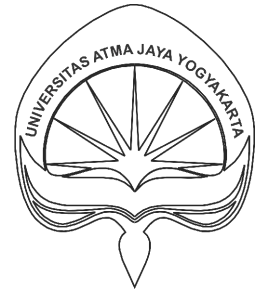

PROGRAM STUDI TEKNIK SIPIL
FAKULTAS TEKNIK
UNIVERSITAS ATMA JAYA
YOGYAKARTA

SPESIFIKASI

ANGGOTA KELOMPOK :

SAMUEL NABABAN
(190217720)
JUAN PATRICK SOASA
(190217677)
RICHARDUS ALGA ADMAJA
(190217656)

DOSEN PENGAJAR :

Ir. HARYANTO YW., M.T.
VIENTI HADSARI, S.T., M.Eng., MECRES, Ph.D.
DIDIT GUNAWAN PRASETYO JATI, S.Kom, M.Sc.

DOSEN PEMBIMBING :

SISWADI, S.T., M.T.

GAMBAR

SKALA

DAFTAR GAMBAR
ELEKTRIKAL&PEMIPAAN

1:100

KODE GAMBAR	NO GAMBAR	JML. GAMBAR
EP	01	15



PROGRAM STUDI TEKNIK SIPIL
 FAKULTAS TEKNIK
 UNIVERSITAS ATMA JAYA
 YOGYAKARTA

SPESIFIKASI

ANGGOTA KELOMPOK :

SAMUEL NABABAN
 (190217720)
 JUAN PATRICK SOASA
 (190217677)
 RICHARDUS ALGA ADMAJA
 (190217656)

DOSEN PENGAJAR :

Ir. HARYANTO YW., M.T.
 VIENTI HADSARI, S.T., M.Eng., MECRES, Ph.D.
 DIDIT GUNAWAN PRASETYO JATI, S.Kom, M.Sc.

DOSEN PEMBIMBING :

SISWADI, S.T., M.T.

GAMBAR

SKALA

DENAH INSTALASI AIR
 BERSIH LANTAI 1

1:100

KODE GAMBAR NO GAMBAR JML. GAMBAR

EP 02 15

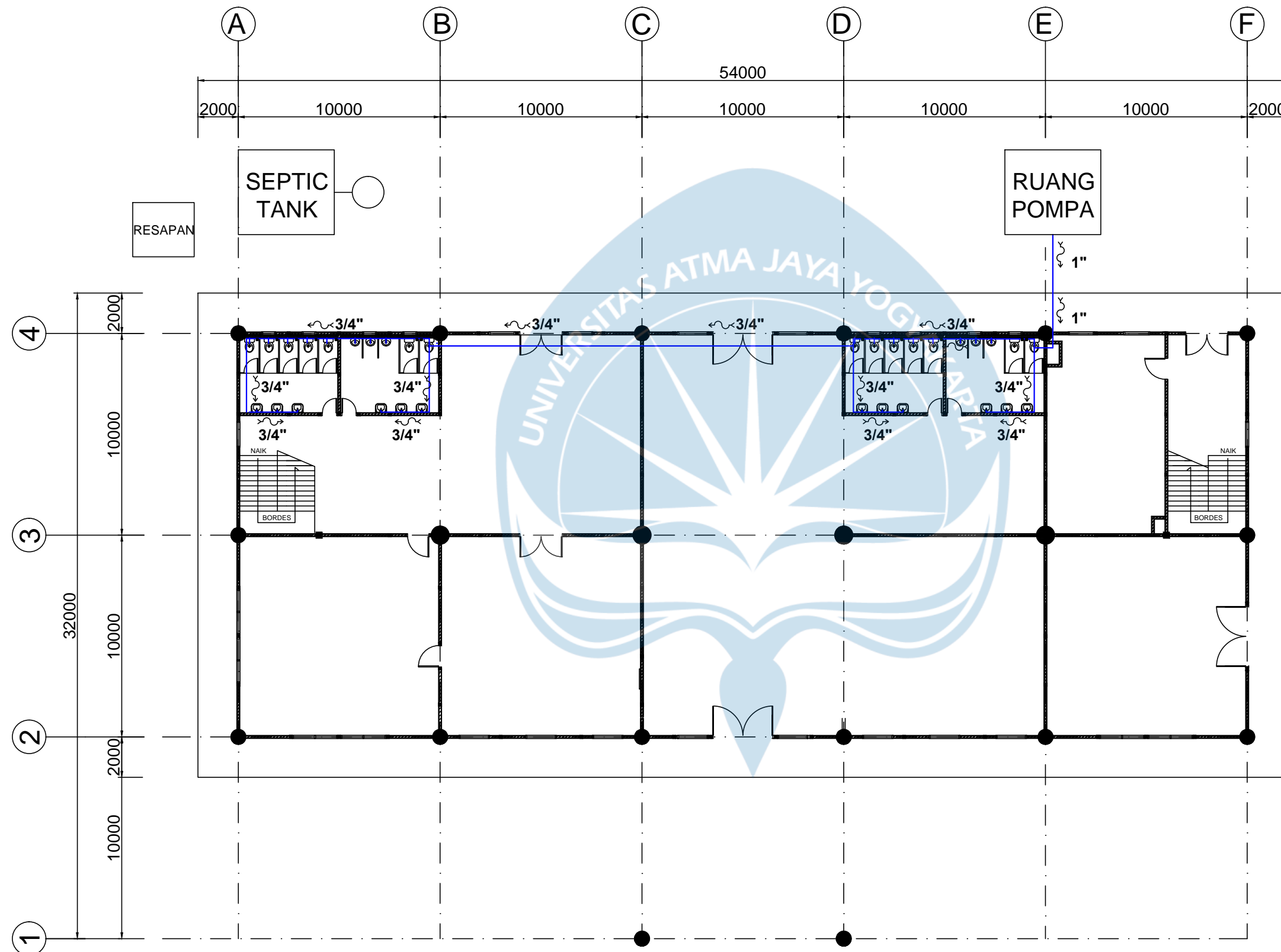

DENAH INSTALASI AIR BERSIH LANTAI 1

1:100



PROGRAM STUDI TEKNIK SIPIL
 FAKULTAS TEKNIK
 UNIVERSITAS ATMA JAYA
 YOGYAKARTA

SPESIFIKASI

ANGGOTA KELOMPOK :

SAMUEL NABABAN
 (190217720)
 JUAN PATRICK SOASA
 (190217677)
 RICHARDUS ALGA ADMAJA
 (190217656)

DOSEN PENGAJAR :

Ir. HARYANTO YW., M.T.
 VIENTI HADSARI, S.T., M.Eng., MECRES, Ph.D.
 DIDIT GUNAWAN PRASETYO JATI, S.Kom, M.Sc.

DOSEN PEMBIMBING :

SISWADI, S.T., M.T.

GAMBAR

SKALA

DENAH INSTALASI AIR
 BERSIH LANTAI 2

1:100

KODE GAMBAR NO GAMBAR JML. GAMBAR

EP 03 15

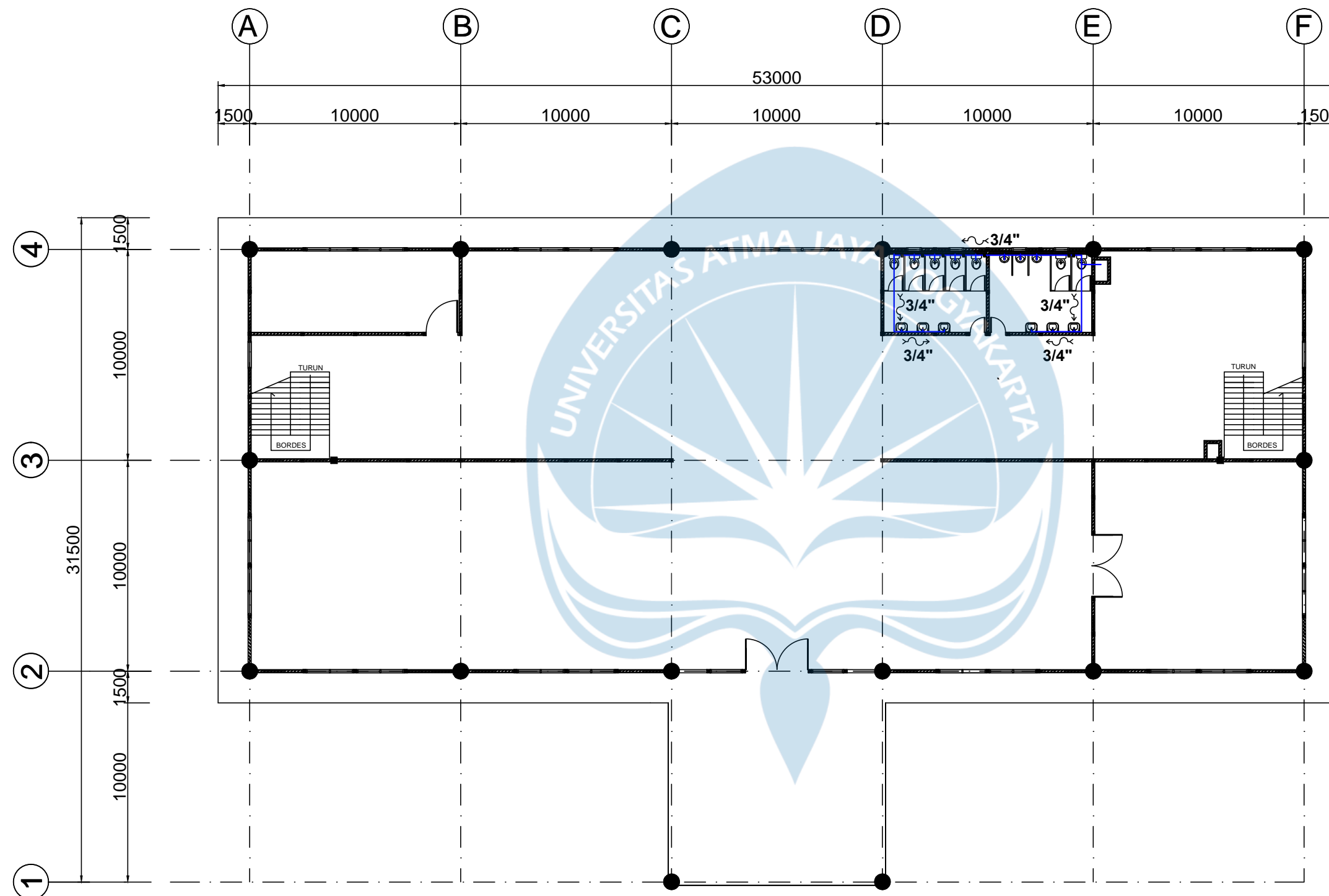

DENAH INSTALASI AIR BERSIH LANTAI 2

1:100

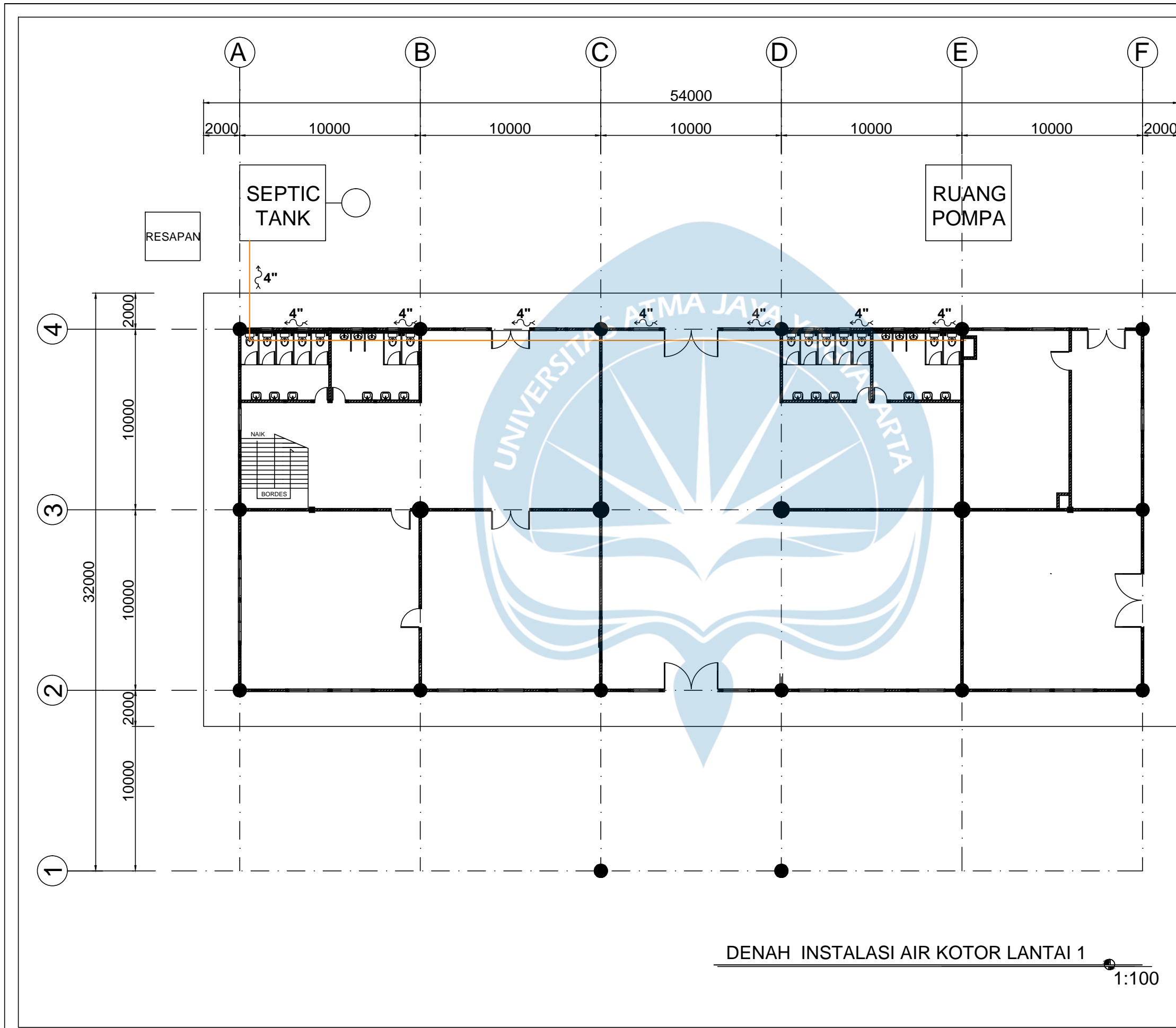

DENAH INSTALASI AIR KOTOR LANTAI 1
1:100



PROGRAM STUDI TEKNIK SIPIL
FAKULTAS TEKNIK
UNIVERSITAS ATMA JAYA
YOGYAKARTA

SPESIFIKASI

ANGGOTA KELOMPOK :
SAMUEL NABABAN
(190217720)
JUAN PATRICK SOASA
(190217677)
RICHARDUS ALGA ADMAJA
(190217656)

DOSEN PENGAJAR :
Ir. HARYANTO YW., M.T.
VIENTI HADSARI, S.T., M.Eng., MECRES, Ph.D.
DIDIT GUNAWAN PRASETYO JATI, S.Kom, M.Sc.

DOSEN PEMBIMBING :
SISWADI, S.T., M.T.

GAMBAR		SKALA
DENAH INSTALASI AIR KOTOR LANTAI 1		1:100
KODE GAMBAR	NO GAMBAR	JML. GAMBAR
EP	04	15

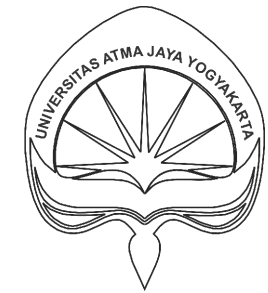

PROGRAM STUDI TEKNIK SIPIL
 FAKULTAS TEKNIK
 UNIVERSITAS ATMA JAYA
 YOGYAKARTA

SPESIFIKASI

ANGGOTA KELOMPOK :
 SAMUEL NABABAN
 (190217720)
 JUAN PATRICK SOASA
 (190217677)
 RICHARDUS ALGA ADMAJA
 (190217656)

DOSEN PENGAJAR :
 Ir. HARYANTO YW., M.T.
 VIENTI HADSARI, S.T., M.Eng., MECRES, Ph.D.
 DIDIT GUNAWAN PRASETYO JATI, S.Kom, M.Sc.

DOSEN PEMBIMBING :
 SISWADI, S.T., M.T.

GAMBAR		SKALA
DENAH INSTALASI AIR KOTOR LANTAI 2		1:100
KODE GAMBAR	NO GAMBAR	JML. GAMBAR
EP	05	15

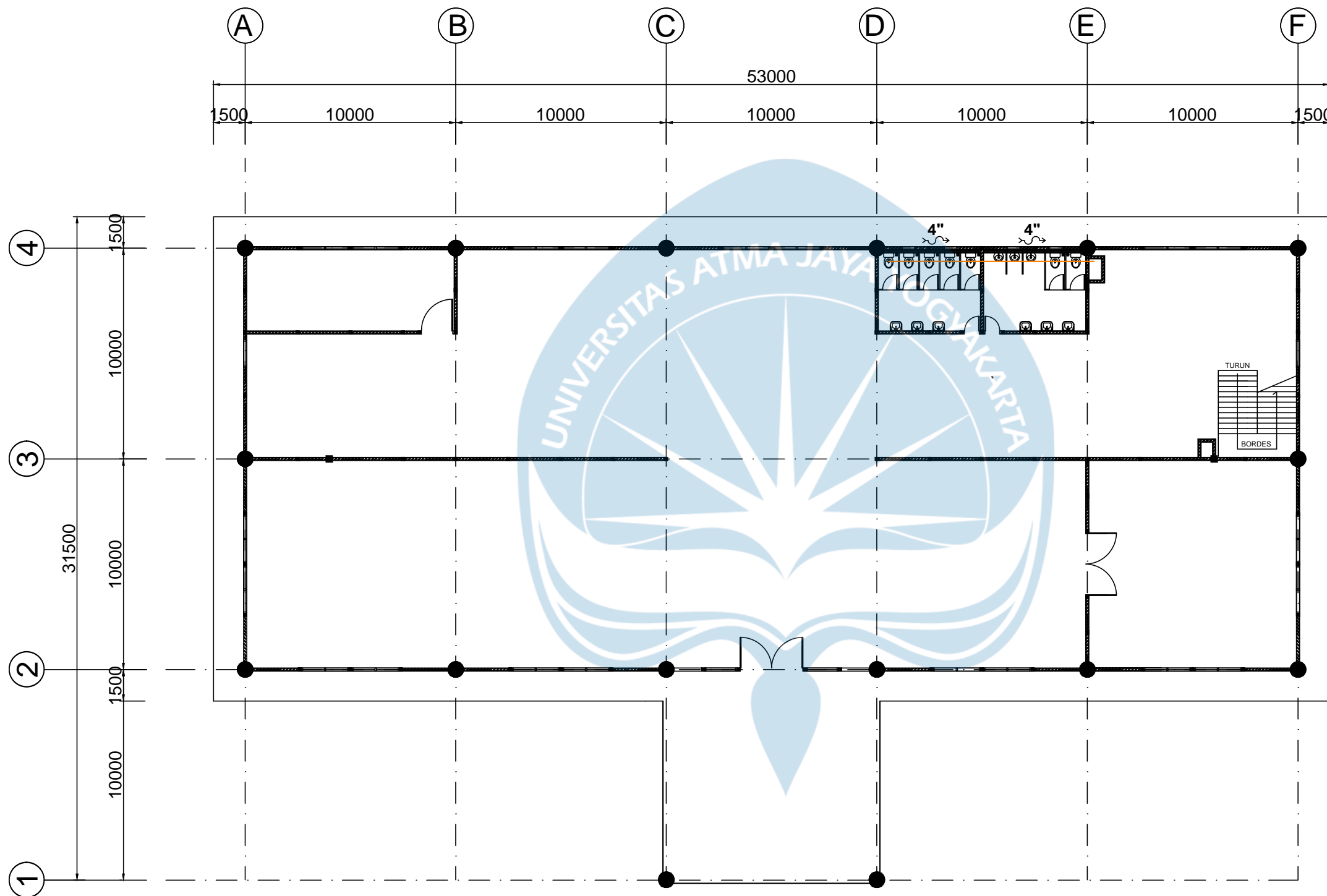

DENAH INSTALASI AIR KOTOR LANTAI 2 1:100

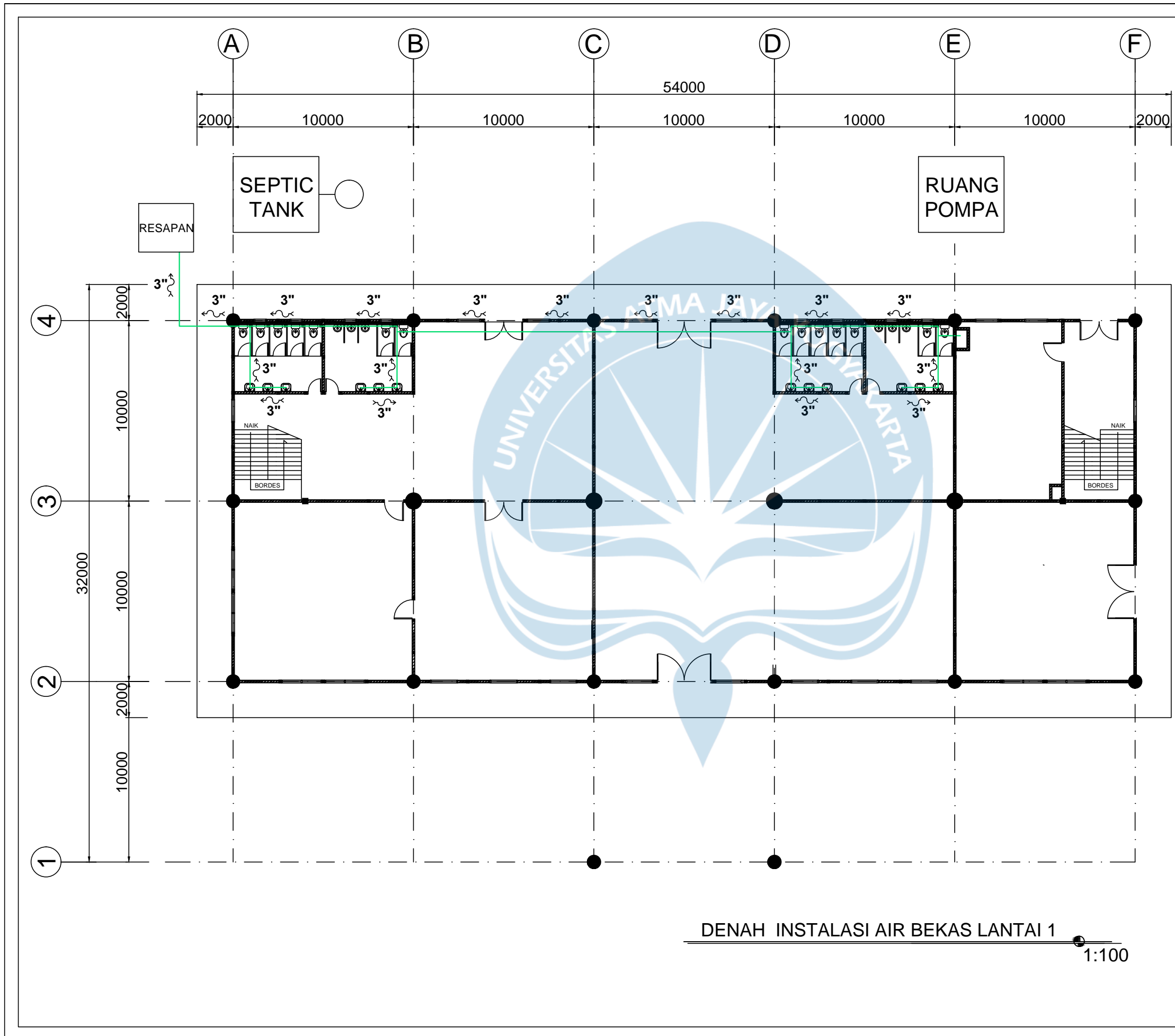

DENAH INSTALASI AIR BEKAS LANTAI 1
1:100



PROGRAM STUDI TEKNIK SIPIL
 FAKULTAS TEKNIK
 UNIVERSITAS ATMA JAYA
 YOGYAKARTA

SPESIFIKASI

ANGGOTA KELOMPOK :
 SAMUEL NABABAN
 (190217720)
 JUAN PATRICK SOASA
 (190217677)
 RICHARDUS ALGA ADMAJA
 (190217656)

DOSEN PENGAJAR :
 Ir. HARYANTO YW., M.T.
 VIENTI HADSARI, S.T., M.Eng., MECRES, Ph.D.
 DIDIT GUNAWAN PRASETYO JATI, S.Kom, M.Sc.

DOSEN PEMBIMBING :
 SISWADI, S.T., M.T.

GAMBAR	SKALA	
DENAH INSTALASI AIR BEKAS LANTAI 1	1:100	
KODE GAMBAR	NO GAMBAR	JML. GAMBAR
EP	06	15



PROGRAM STUDI TEKNIK SIPIL
 FAKULTAS TEKNIK
 UNIVERSITAS ATMA JAYA
 YOGYAKARTA

SPESIFIKASI

ANGGOTA KELOMPOK :
 SAMUEL NABABAN
 (190217720)
 JUAN PATRICK SOASA
 (190217677)
 RICHARDUS ALGA ADMAJA
 (190217656)

DOSEN PENGAJAR :
 Ir. HARYANTO YW., M.T.
 VIENTI HADSARI, S.T., M.Eng., MECRES, Ph.D.
 DIDIT GUNAWAN PRASETYO JATI, S.Kom, M.Sc.

DOSEN PEMBIMBING :
 SISWADI, S.T., M.T.

GAMBAR		SKALA
DENAH INSTALASI AIR BEKAS LANTAI 2		1:100
KODE GAMBAR	NO GAMBAR	JML. GAMBAR
EP	07	15

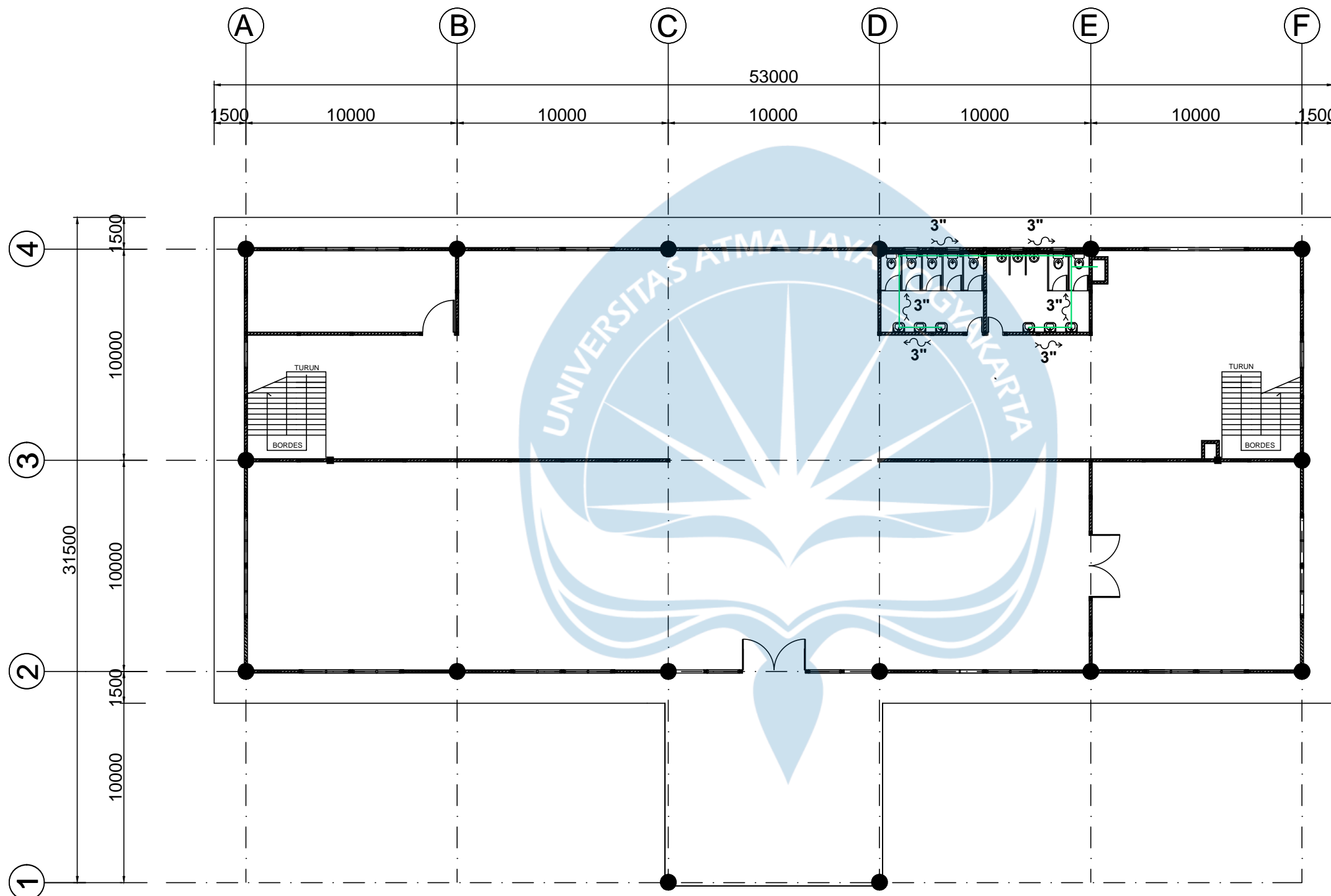

DENAH INSTALASI AIR BEKAS LANTAI 2 1:100



PROGRAM STUDI TEKNIK SIPIL
 FAKULTAS TEKNIK
 UNIVERSITAS ATMA JAYA
 YOGYAKARTA

SPESIFIKASI

ANGGOTA KELOMPOK :

SAMUEL NABABAN
 (190217720)
 JUAN PATRICK SOASA
 (190217677)
 RICHARDUS ALGA ADMAJA
 (190217656)

DOSEN PENGAJAR :

Ir. HARYANTO YW., M.T.
 VIENTI HADSARI, S.T., M.Eng., MECRES, Ph.D.
 DIDIT GUNAWAN PRASETYO JATI, S.Kom, M.Sc.

DOSEN PEMBIMBING :

SISWADI, S.T., M.T.

GAMBAR

SKALA

DENAH INSTALASI AIR
 HUJAN LANTAI 1

1:100

KODE GAMBAR NO GAMBAR JML. GAMBAR

EP 08 15

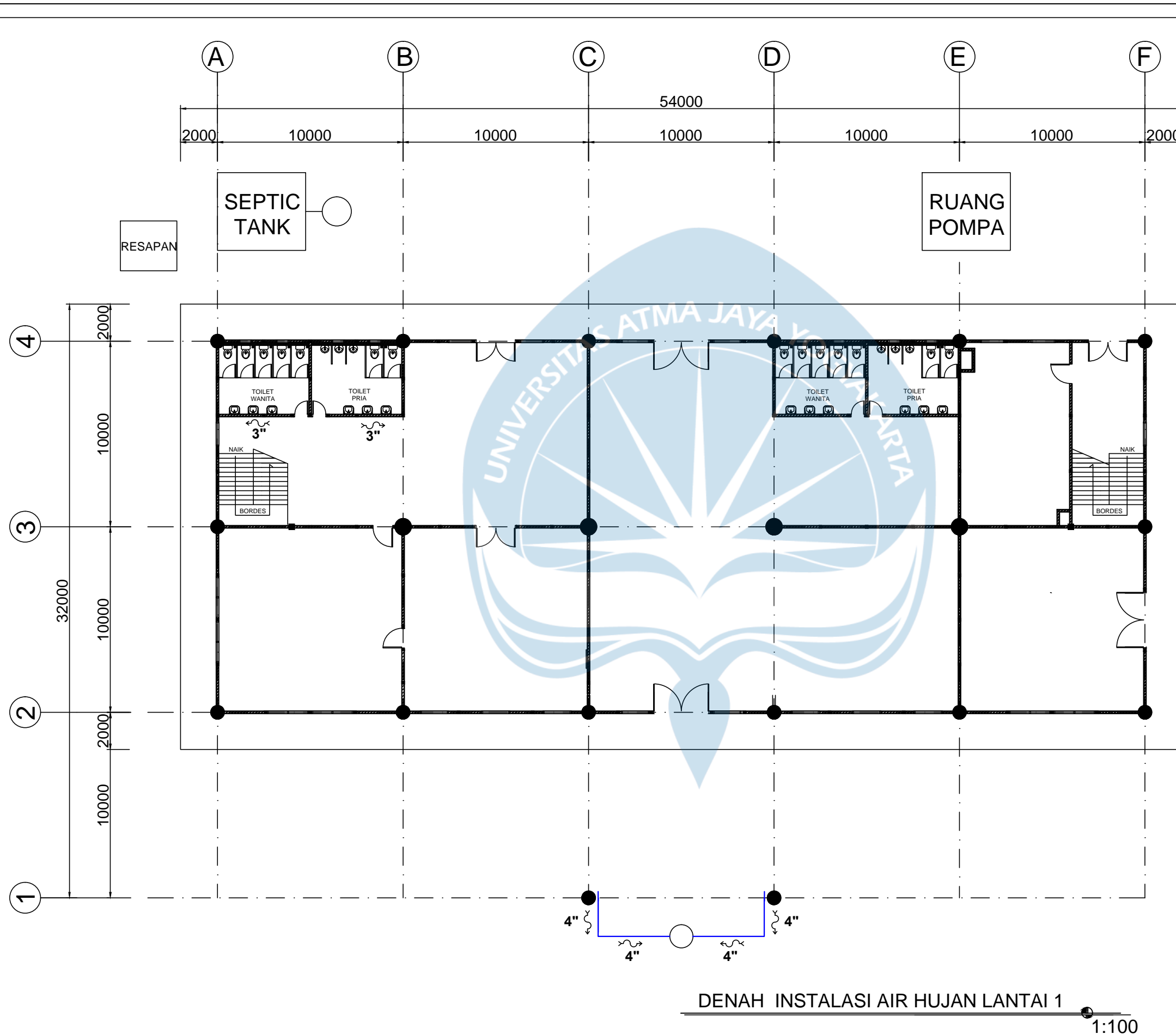

DENAH INSTALASI AIR HUJAN LANTAI 1

1:100



PROGRAM STUDI TEKNIK SIPIL
 FAKULTAS TEKNIK
 UNIVERSITAS ATMA JAYA
 YOGYAKARTA

SPESIFIKASI

ANGGOTA KELOMPOK :

SAMUEL NABABAN
 (190217720)
 JUAN PATRICK SOASA
 (190217677)
 RICHARDUS ALGA ADMAJA
 (190217656)

DOSEN PENGAJAR :

Ir. HARYANTO YW., M.T.
 VIENTI HADSARI, S.T., M.Eng., MECRES, Ph.D.
 DIDIT GUNAWAN PRASETYO JATI, S.Kom, M.Sc.

DOSEN PEMBIMBING :

SISWADI, S.T., M.T.

GAMBAR

SKALA

DENAH INSTALASI AIR
 HUJAN LANTAI 2

1:100

KODE GAMBAR NO GAMBAR JML. GAMBAR

EP 09 15

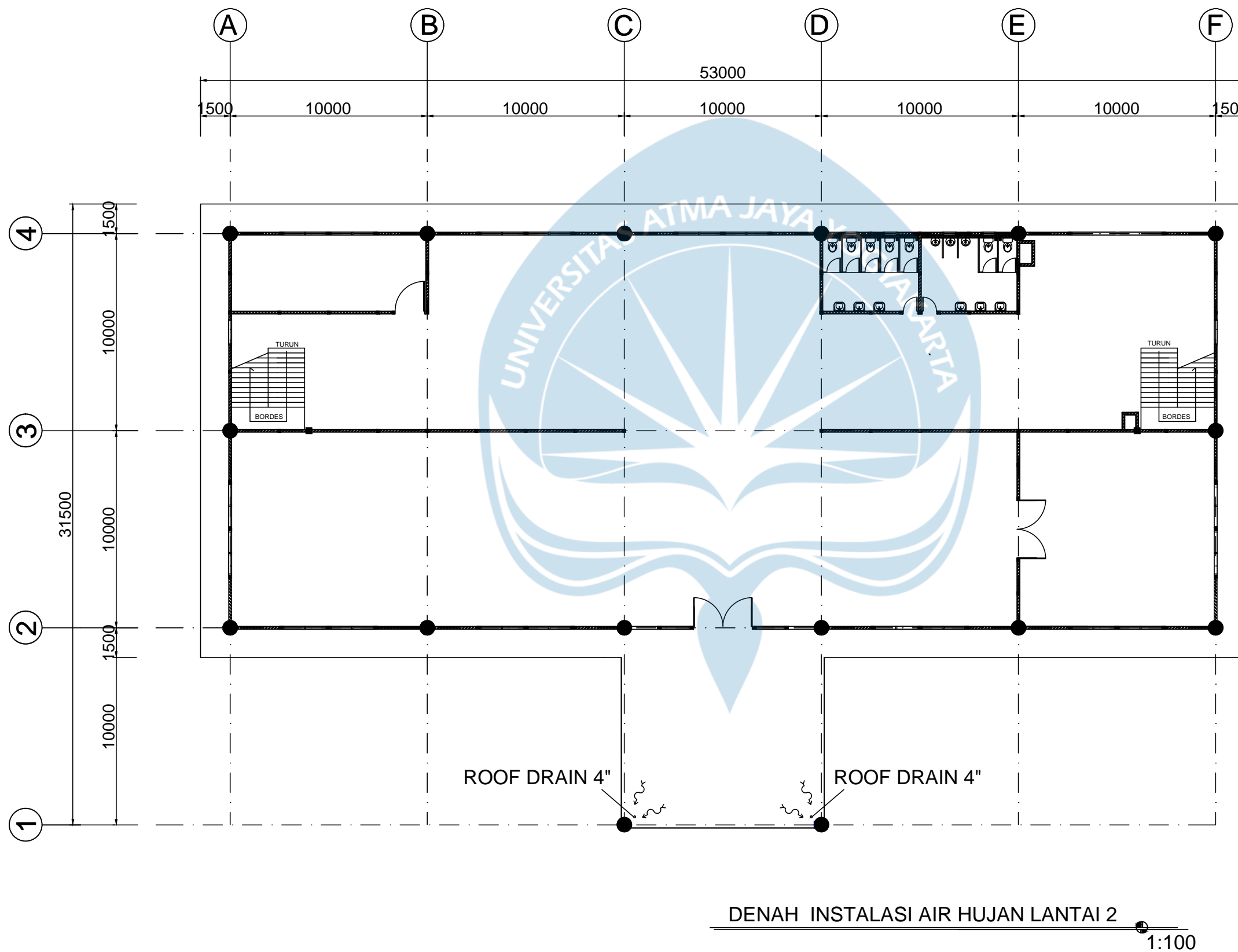

DENAH INSTALASI AIR HUJAN LANTAI 2

1:100



PROGRAM STUDI TEKNIK SIPIL
 FAKULTAS TEKNIK
 UNIVERSITAS ATMA JAYA
 YOGYAKARTA

SPESIFIKASI

ANGGOTA KELOMPOK :

SAMUEL NABABAN
 (190217720)
 JUAN PATRICK SOASA
 (190217677)
 RICHARDUS ALGA ADMAJA
 (190217656)

DOSEN PENGAJAR :

Ir. HARYANTO YW., M.T.
 VIENTI HADSARI, S.T., M.Eng., MECRES, Ph.D.
 DIDIT GUNAWAN PRASETYO JATI, S.Kom, M.Sc.

DOSEN PEMBIMBING :

SISWADI, S.T., M.T.

GAMBAR	SKALA
--------	-------

DENAH INSTALASI PENERANGAN LANTAI 1	1:100
-------------------------------------	-------

KODE GAMBAR	NO GAMBAR	JML. GAMBAR
-------------	-----------	-------------

EP	10	15
----	----	----

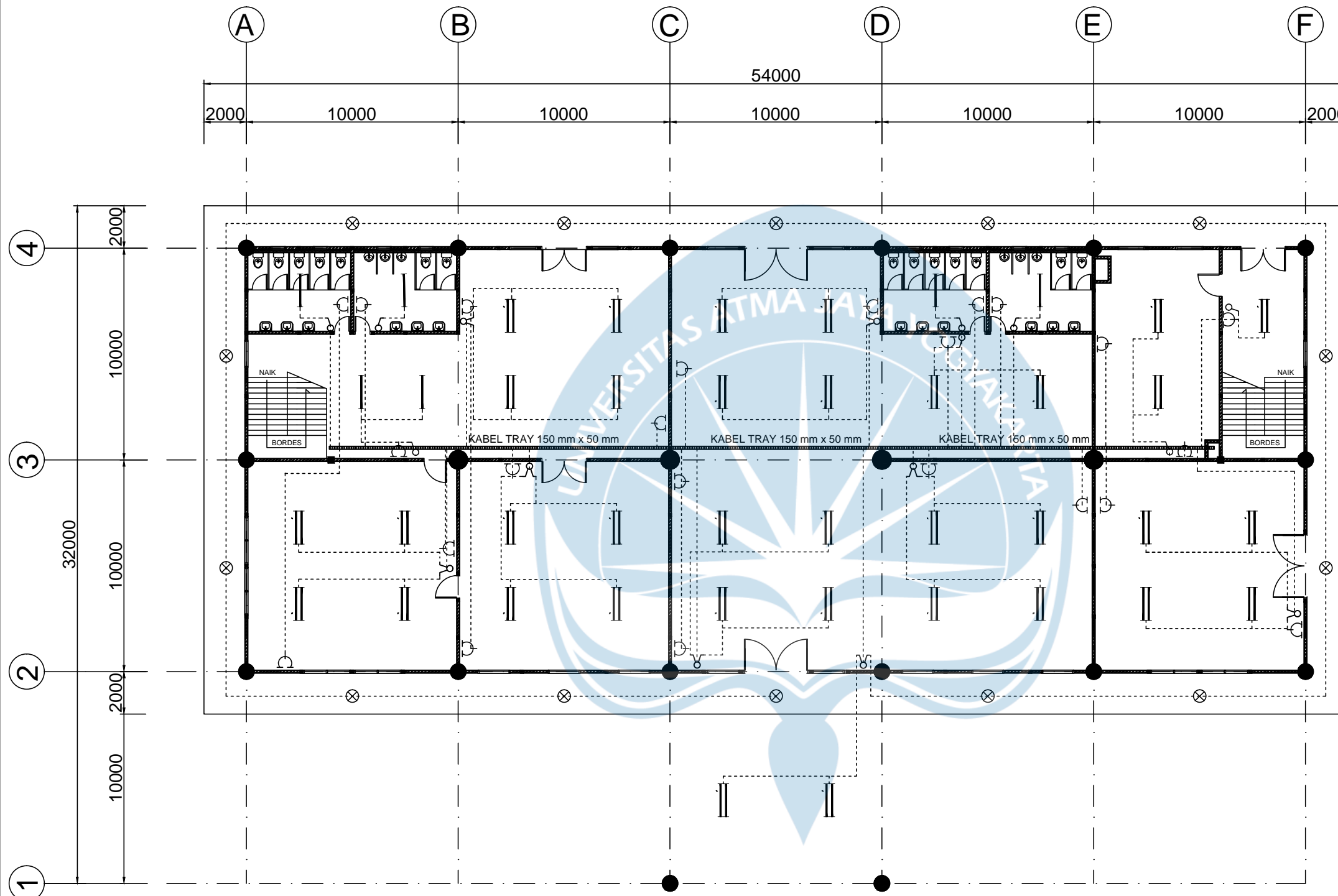

- || TL LED 2x14 WATT : 35 BUAH
- | TL LED 14 WATT : 4 BUAH
- ⊗ BOHLAM LED 10 WATT : 14 BUAH
- ⌋ STOP KONTAK 250 WATT : 23 BUAH
- ⌋ SAKLAR SATU GANG : 10 BUAH
- ⌋ SAKLAR DUA GANG : 8 BUAH

DENAH INSTALASI PENERANGAN LANTAI 1 1:100



PROGRAM STUDI TEKNIK SIPIL
 FAKULTAS TEKNIK
 UNIVERSITAS ATMA JAYA
 YOGYAKARTA

SPESIFIKASI

ANGGOTA KELOMPOK :

SAMUEL NABABAN
 (190217720)
 JUAN PATRICK SOASA
 (190217677)
 RICHARDUS ALGA ADMAJA
 (190217656)

DOSEN PENGAJAR :

Ir. HARYANTO YW., M.T.
 VIENTI HADSARI, S.T., M.Eng., MECRES, Ph.D.
 DIDIT GUNAWAN PRASETYO JATI, S.Kom, M.Sc.

DOSEN PEMBIMBING :

SISWADI, S.T., M.T.

GAMBAR

SKALA

DENAH INSTALASI
 PENERANGAN LANTAI 2

1:100

KODE GAMBAR	NO GAMBAR	JML. GAMBAR
-------------	-----------	-------------

EP	11	15
----	----	----

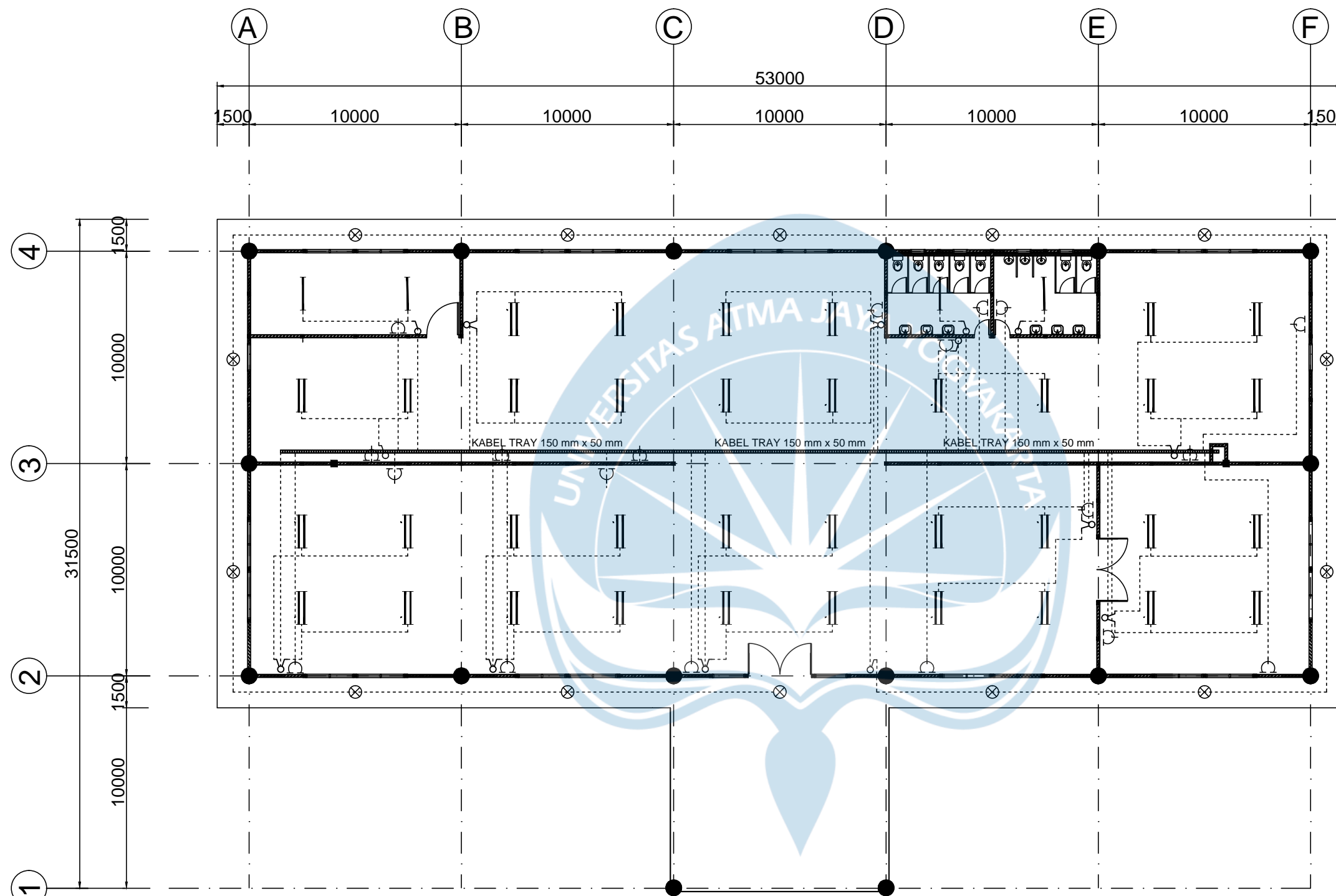

- || TL LED 2x14 WATT : 36 BUAH
- TL LED 14 WATT : 4 BUAH
- ⊗ BOHLAM LED 10 WATT : 14 BUAH
- ⌋ STOP KONTAK 250 WATT : 17 BUAH
- ⌋ SAKLAR SATU GANG : 5 BUAH
- ⌋ SAKLAR DUA GANG : 8 BUAH

DENAH INSTALASI PENERANGAN LANTAI 2 1:100



PROGRAM STUDI TEKNIK SIPIL
 FAKULTAS TEKNIK
 UNIVERSITAS ATMA JAYA
 YOGYAKARTA

SPESIFIKASI

ANGGOTA KELOMPOK :

SAMUEL NABABAN
 (190217720)
JUAN PATRICK SOASA
 (190217677)
RICHARDUS ALGA ADMAJA
 (190217656)

DOSEN PENGAJAR :

Ir. HARYANTO YW., M.T.
 VIENTI HADSARI, S.T., M.Eng., MECRES, Ph.D.
 DIDIT GUNAWAN PRASETYO JATI, S.Kom, M.Sc.

DOSEN PEMBIMBING :

SISWADI, S.T., M.T.

GAMBAR

SKALA

DENAH INSTALASI CCTV
 LANTAI 1

1:100

KODE GAMBAR NO GAMBAR JML. GAMBAR

EP 12 15

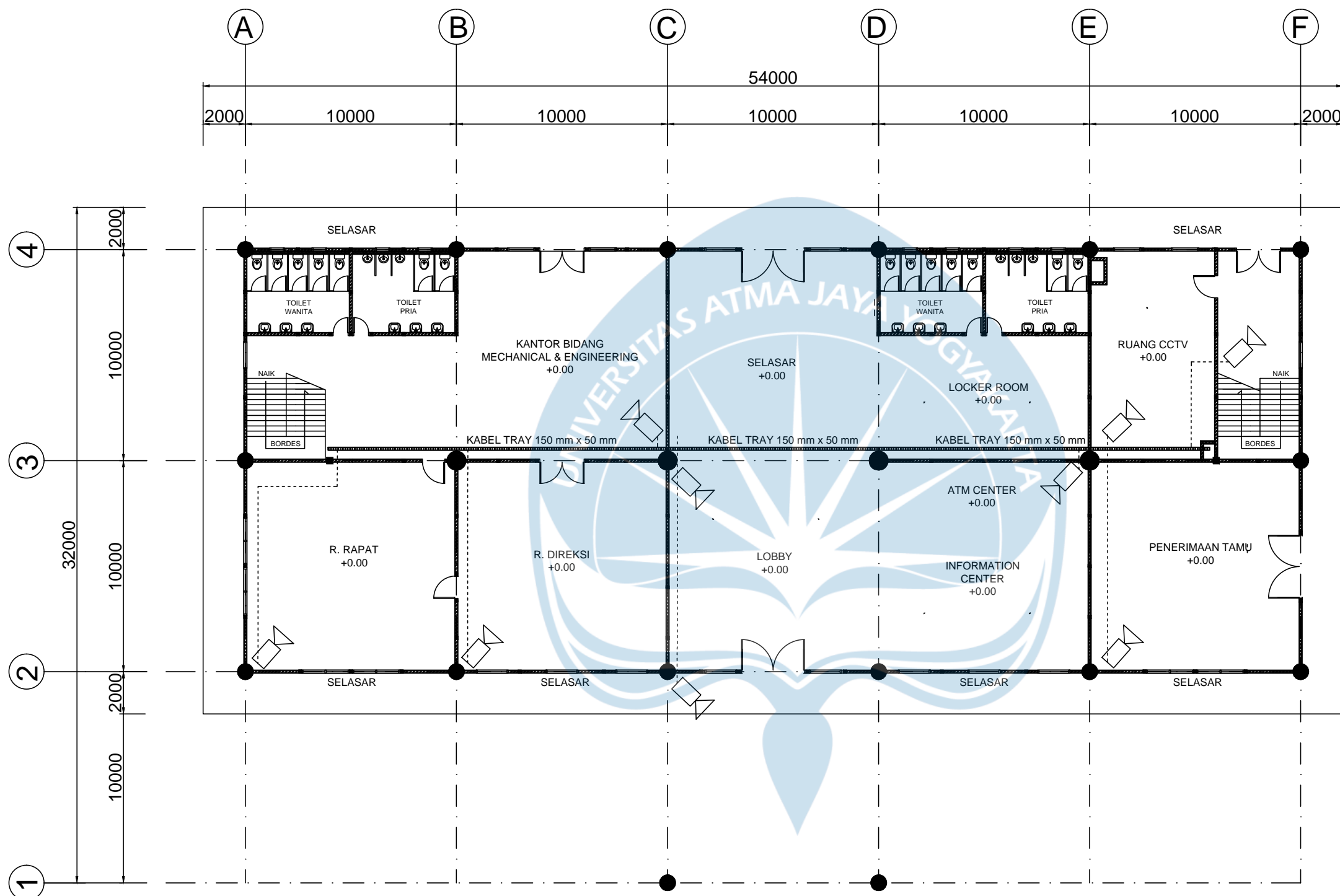

□ CCTV : 10 TITIK

DENAH INSTALASI CCTV LANTAI 1
 1:100



PROGRAM STUDI TEKNIK SIPIL
 FAKULTAS TEKNIK
 UNIVERSITAS ATMA JAYA
 YOGYAKARTA

SPESIFIKASI

ANGGOTA KELOMPOK :

SAMUEL NABABAN
 (190217720)
 JUAN PATRICK SOASA
 (190217677)
 RICHARDUS ALGA ADMAJA
 (190217656)

DOSEN PENGAJAR :

Ir. HARYANTO YW., M.T.
 VIENTI HADSARI, S.T., M.Eng., MECRES, Ph.D.
 DIDIT GUNAWAN PRASETYO JATI, S.Kom, M.Sc.

DOSEN PEMBIMBING :

SISWADI, S.T., M.T.

GAMBAR	SKALA
--------	-------

DENAH INSTALASI CCTV LANTAI 2	1:100
-------------------------------	-------

KODE GAMBAR	NO GAMBAR	JML. GAMBAR
EP	13	15

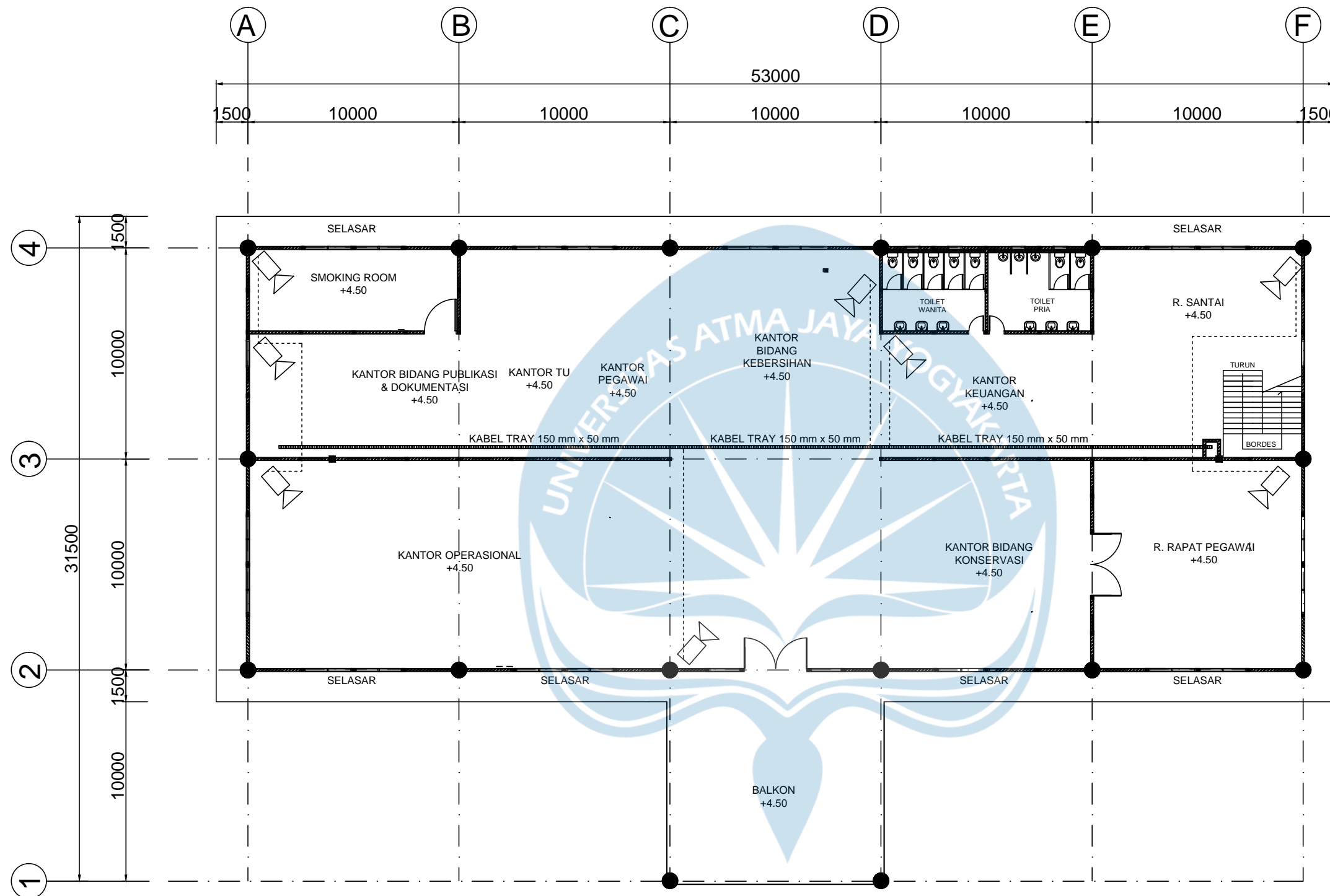

CCTV : 8 TITIK

DENAH INSTALASI CCTV LANTAI 2 1:100

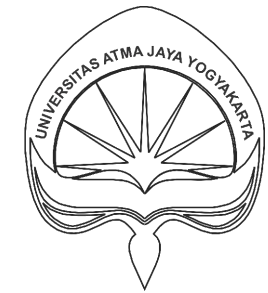

PROGRAM STUDI TEKNIK SIPIL
 FAKULTAS TEKNIK
 UNIVERSITAS ATMA JAYA
 YOGYAKARTA

SPESIFIKASI

ANGGOTA KELOMPOK :

SAMUEL NABABAN
 (190217720)
 JUAN PATRICK SOASA
 (190217677)
 RICHARDUS ALGA ADMAJA
 (190217656)

DOSEN PENGAJAR :

Ir. HARYANTO YW., M.T.
 VIENTI HADSARI, S.T., M.Eng., MECRES, Ph.D.
 DIDIT GUNAWAN PRASETYO JATI, S.Kom, M.Sc.

DOSEN PEMBIMBING :

SISWADI, S.T., M.T.

GAMBAR	SKALA
--------	-------

DENAH INSTALASI WIFI LANTAI 1	1:100
-------------------------------	-------

KODE GAMBAR	NO GAMBAR	JML. GAMBAR
EP	14	15

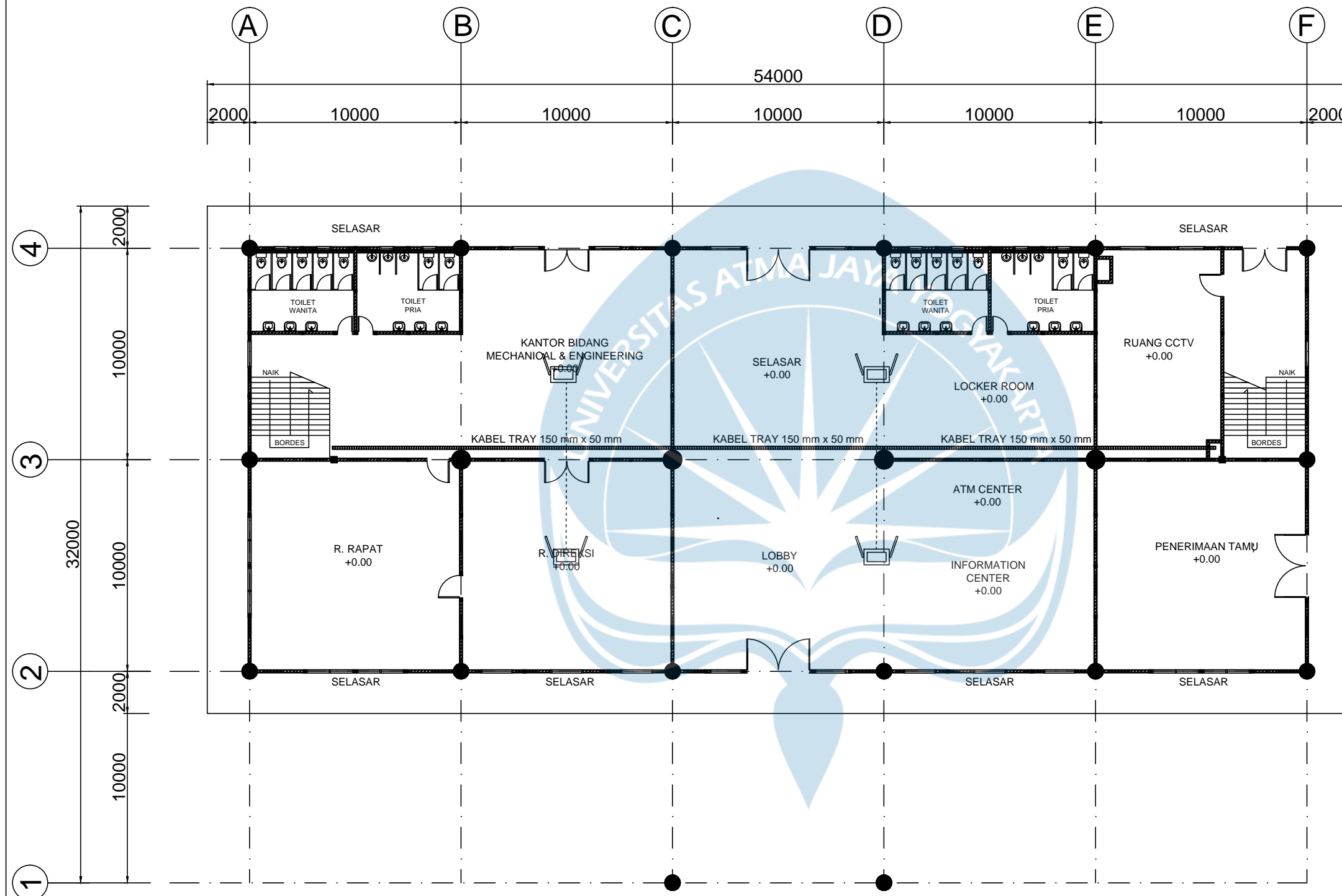

JUMLAH :
 WIFI : 4 TITIK

DENAH INSTALASI WIFI LANTAI 1
 1:100



PROGRAM STUDI TEKNIK SIPIL
 FAKULTAS TEKNIK
 UNIVERSITAS ATMA JAYA
 YOGYAKARTA

SPESIFIKASI

ANGGOTA KELOMPOK :

SAMUEL NABABAN
 (190217720)
 JUAN PATRICK SOASA
 (190217677)
 RICHARDUS ALGA ADMAJA
 (190217656)

DOSEN PENGAJAR :

Ir. HARYANTO YW., M.T.
 VIENTI HADSARI, S.T., M.Eng., MECRES, Ph.D.
 DIDIT GUNAWAN PRASETYO JATI, S.Kom, M.Sc.

DOSEN PEMBIMBING :

SISWADI, S.T., M.T.

GAMBAR

SKALA

DENAH INSTALASI WIFI
 LANTAI 2

1:100

KODE GAMBAR NO GAMBAR JML. GAMBAR

EP 15 15

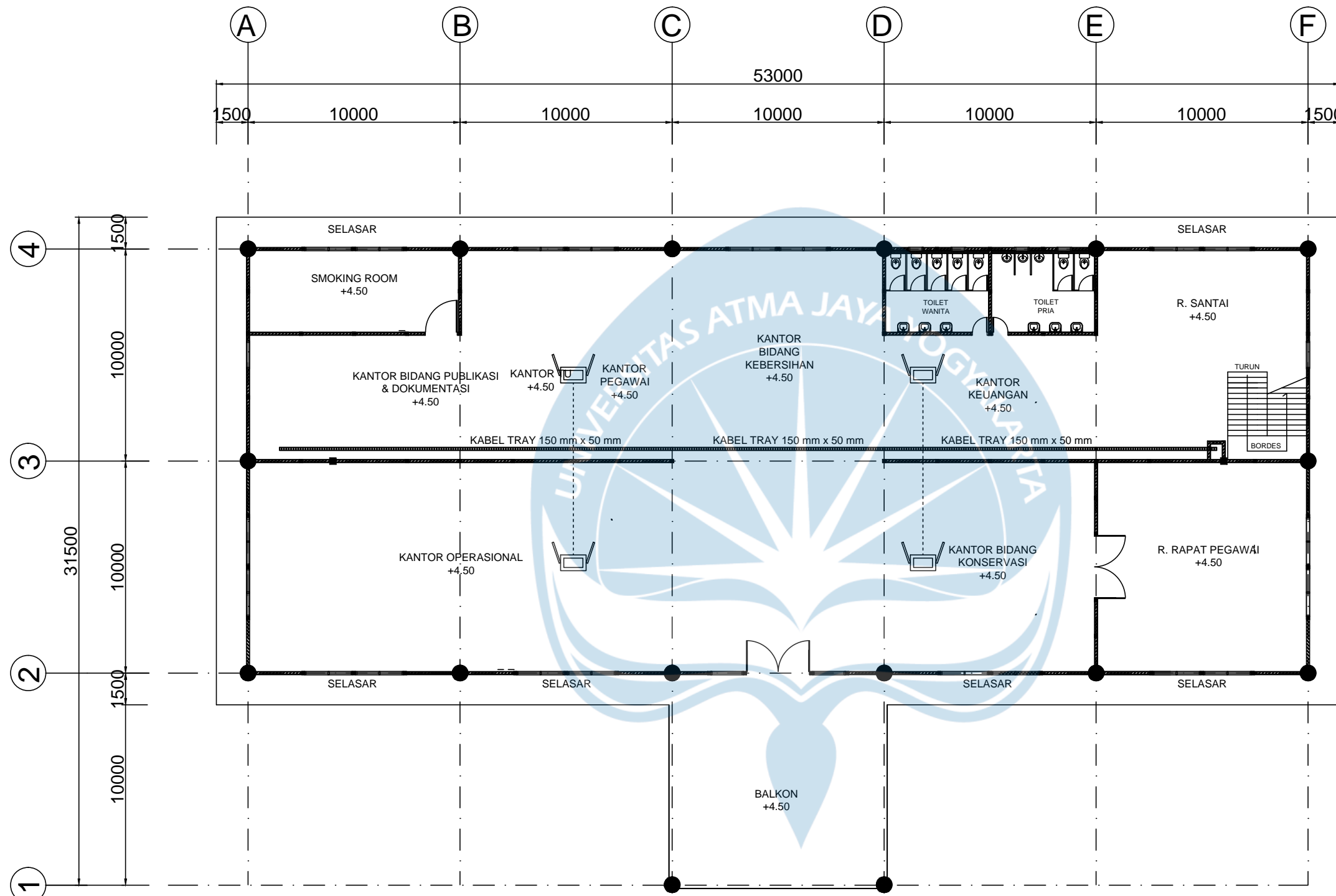

JUMLAH :
 WIFI : 4 TITIK

DENAH INSTALASI WIFI LANTAI 2 1:100

Lampiran B.4. Rekapitulasi Perhitungan Volume

Detail Perhitungan Volume Galian Tanah	
Elevasi	Volume (m3)
151.6-151.6	32.20757
152-151.6	242.90583
152.2-152	434.27388
152-152.2	577.91064
151.7-152	262.99399
151.5-151.7	35.978
Total Galian	1586.26991

Detail Perhitungan Volume Pemasatan Tanah	
Elevasi	Volume (m3)
151-151.5	32.51815

Detail Pekerjaan Pondasi		
Tiang Pancang	60	buah

Pekerjaan Galian tanah (m3)	
Pile Cap Tipe P1	120.744
Pile Cap Tipe P2	172.23564
Pile Cap Tipe P2	196.209
Sloof	41.445
Total	530.63364

Pekerjaan Urugan Pasir tebal 10 cm (m3)	
Pile Cap Tipe P1	0
Pile Cap Tipe P2	3.564
Pile Cap Tipe P3	6.41096
Pile Cap Tipe P4	6.534
Sloof	6.9075
Total	23.41646

Pekerjaan Lantai Kerja tebal 5 cm (m3)	
Pile Cap Tipe P1	0
Pile Cap Tipe P2	1.782
Pile Cap Tipe P3	3.20548
Pile Cap Tipe P4	3.267
Sloof	3.45375
Total	11.70823

Kebutuhan tulangan Pilecap 2		
	panjang	berat (kg)
Panjang 1	46.038	102.342474
Panjang 2	44.09	98.01207
Total	90.128	200.354544
Panjang 1	56.287	58.53848
Panjang 2	56.336	58.58944
Kebutuhan besi	117.12792	Kg
Volume Beton	3.9919292	m3
Volume Bekisting	13.5852	m2

Detail Perhitungan Volume Pekerjaan Kolom Pedestal				
	Tipe 1	Tipe 2	Total	Satuan
Volume Tulangan Utama	0.106029	0.282743	0.3888	m3
Berat Tulangan	832.3257	2219.535	3051.9	Kg
Jumlah tulangan sengkang	240	960	1200	
Volume Tulangan Sengkang	0.09007	0.300233	0.3903	m3
berat tulangan sengkang	707.0496	2356.832	3063.9	Kg
Total Besi	1539.375	4576.367	6115.7	Kg
Volume Beton	3.620936	10.0199	13.641	m3
Bekisting	16.9646	56.54867	73.513	m2

Volume pekerjaan pilecap 1 dan pilecap 3																
Jenis	Panjang	Lebar	Tebal	D. tul tarik	D. tul tekan	spasi. Tul tarik	Spasi tekan	n1.tarik	n2.tarik	n1. tekan	n2. tekan	p.tarik	p.tekan	Berat (kg)	Volume Beton(m)	Volume bekisting
Tipe 1	3300	1800	500	19	13	300	150	7	12	13	23	58	82.5	214.734	2.942645	5.1
Tipe 3	3300	3300	500	19	13	150	150	23	23	23	23	184	149.5	945.047	5.324612	6.6

catatan: Volume pekerjaan yang dihitung merupakan volume untuk 1 buah pile cap.

Volume pekerjaan Sloof																				
Komponen	lebar	tinggi	Panjang	jumlah	n atas	n bawah	D.Tul Utama	D. Tul sengkang	spasi. lap	spasi. Tumpua	dia. pinggang	Jumlah sengkang	n. pingga	P. Tul Utama	P. Tul. sengkang	P. Tul pinggang	Berat Tekuk + sambungan	Berat Tulangan	Volume beton	Bekisting (m2)
Sloof 1	250	450	10000	17	2	2	16	8	50	50	13	185	2	40	211.64	20	50.395008	2847.8	17.3278	180.8375
Sloof 2	250	450	10000	10	2	2	16	8	50	50	13	184	2	40	210.496	20		1670.66	10.1091	105.2875
Sloof 3	250	450	10000	3	2	2	16	8	50	50	13	182	2	40	208.208	20		498.486	3.00775	31.3275
Total																		5016.95	30.4446	317.4525

Detail Kolom K1 Lantai 1		Satuan
Volume Tulangan Utama	0.318086	m3
Berat Tulangan	2496.977	Kg
Jumlah tulangan sengkang	240	
Volume Tulangan Sengkang	0.09007	m3
berat sengkang	707.0496	m3
Berat Besi	3204.027	Kg
Volume Beton	11.04295	m3
Bekisting	50.8938	m2

Detail Kolom K2 Lantai 2		Satuan
Volume Tulangan Utama	0.84823	m3
Berat Tulangan	6658.6056	Kg
Jumlah tulangan sengkang	960	
Volume Tulangan Sengkang	0.3002334	m3
berat tulangan sengkang	2356.8319	m3
Berat Besi	9015.4376	Kg
Volume Beton	30.660162	m3
Bekisting	169.646	m2

Perhitungan Volume bekisting Lantai 2		
Luas alas	1046.7666	m2
Luas u pinggir	22.1286	m2
Jadi, total	1068.8952	m2

Detail Kolom K2 Lantai 1		Satuan
Volume Tulangan Utama	0.84823	m3
Berat Tulangan	6658.6056	Kg
Jumlah tulangan sengkang	960	
Volume Tulangan Sengkang	0.3002334	m3
berat tulangan sengkang	2356.8319	m3
Berat Besi	9015.4376	Kg
Volume Beton	30.660162	m3
Bekisting	169.646	m2

Perhitungan Volume beton Lantai 2		
Komponen	Volume	Satuan
Luas Full	1327.6173	m2
Area tangga	14.4175	m2
BL	35.5	m2
BK	7.2	m2
B1	60	m2
B2	56	m2
BA	99	M2
Luas k1 (jmlh 4)	2.5457143	m2
Luas k2 (jmlh 14)	6.1875	m2
Volume beton plat lantai 2	126.65998	m3

Detail perhitungan Volume urugan pasir untuk lantai 1 pada bagian dalam bangunan		
Komponen	Volume	Satuan
Luas Dalam Bangunan	1,053.0625	m2
Luas kolom k1 (jmlh 4)	2.5457143	m2
Luas kolom k2 (jmlh 16)	7.0714286	m2
Jadi, pasir urug t=10 cm	104.34454	m3

Detail perhitungan Volume urugan pasir untuk lantai 1 pada bagian luar bangunan		
Komponen	Volume	Satuan
Luas Luar Bangunan	482.9375	m2
Jadi, pasir urug t=10 cm	48.29375	m3

Volume Pekerjaan Tulangan Lantai 2			
Tulangan utama	jumlah btng	panjang	berat (kg)
P1 (panjang)	97	5295.6	3267.4
P1(tengah)	44	460.42	284.077
P1(pendek)	20	942.04	581.239
p2 (panjang)	1404	2055.5	1268.22
P2 (tengah)	364	387.3	238.962
p2(pendek)	182	102.65	63.3338
	Total	9243.5	5703.22

Detail perhitungan Volume Cor Beton untuk lantai 1 pada bagian dalam bangunan		
Komponen	Volume	Satuan
Luas kolom k1 (jmlh 4)	2.54469	m2
Luas kolom k2 (jmlh 16)	7.0685835	m2
Volume Cor Lantai	52.172461	m3

Detail perhitungan Volume Cor Beton untuk lantai 1 pada bagian luar bangunan		
Komponen	Volume	Satuan
Luas Luar Bangunan	482.9375	m2
Volume Cor Lantai	24.1469	m3

Volume Pekerjaan Tulangan Lantai 2			
Tulangan bagi	jumlah btng	panjang	berat (kg)
P1 (pendek)	157	3710.5	1465.66
P1(panjang)	52	1693.3	668.865
P2 (pendek)	84	1985.3	784.176
P2(panjang)	28	911.79	360.158
P1 (pendek)	22	854.83	337.659
P1 (panjang)	10	472.68	186.709
P2(pendek)	10	388.56	153.481
P2(panjang)	4	189.07	74.6834
	Total	10206	4031.39

Komp	lebar (mm)	tinggi (mm)	Panjang (mm)	n atas. Tum	n atas. Lap	n bawah. Tump	n bawah lap	dia. Utama	dia sengkang	spasi. tump	spasi. lap	dia. pinggang	Jumlah sengkang	n. pinggang	P. Tul Utama	P. sengkang	P. Tul pinggang	Berat (tekuk +sambungan)	jumlah komp	Berat tul. (kg)	Volume (m3)	Bekisting (m2)
B1	400	800	10000	10	4	7	7	25	12	50	100	13	135	4	131.75	293.76	40	101.7456	16	12963.57	47.36	296
B2	400	700	10000	6	3	4	4	25	12	50	50	13	185	4	79.75	365.56	40	72.4552	14	9430.033	36.26	233.1
BA	300	550	10000	8	2	4	4	19	8	100	200	13	68	2	85.5	98.192	20	152.0532	33	8238.527	50.3663	427.35
BL	250	600	10000	7	3	5	4	16	8	250	250	13	37	4	89	53.428	40	29.28768	14	2844.045	19.425	187.775
BK	400	600	1500	3	3	2	2	25	12	100	100	13	8	2	5.25	14.208	3	138.744	12	431.6424	2.16	14.4
RB	300	550	10000	3	2	3	3	19	8	100	100	13	93	2	53.5	134.292	20	29.059056	14	2698.862	21.3675	181.3
BB	250	350	4000	2	2	4	6	13	10	50	150	-	44	0	26.5	42.24	0	1.29792	1	53.62208	0.30406	3.30125

Volume Pekerjaan Kuda-Kuda				
Komponen	Panjang (m)	J. komp	Panjang total (m)	Berat (kg)
Kuda-Kuda (2L50)	146.17558	9	1315.58022	4972.893
Kuda-Kuda (2L60)	96.98102	9	872.82918	3636.788

Volume Pekerjaan Gording, Usuk, dan Reng		
Komponen	Panjang (m)	Berat (kg)
Gording	864	5500.8
Usuk	851	1702
Reng	6588	1647

PEKERJAAN PASANGAN DINDING & BETON PRAKTIS

A LANTAI SATU

1 Pasangan Dinding Bata ringan t = 10 cm

Jenis	Panjang	Jumlah Kompo	Total
P1	9,1	15	131,33
P2	7,9	3	22,38
P3	7,02	3	19,74
P4	8,25	2	16,06
P5	8,95	3	25,75
P6	3,85	4	14,96
		Total Panja	230,22

Tinggi Dinding = 4,5-0,6 = 3,9 m

Luas area opening pintu dan jendela = 83,76 m²

Luas dinding = (Tinggi dinding x total panjang dinding) - Luas area opening jendela

= (3,9 x 230,22) - 83,76

= 814,92 m²

3 Plesteran Trasram

Panjang dinding toilet = 77,8 m

Tinggi Dinding = 4,5-0,6 = 3,9 m

Luas = (Tinggi dinding x panjang dinding) x 2

= 77,8 x 3,9 x 2

= 606,84 m²

5 Acian

Total panjang dinding = 230,22 m

Luas dinding = (Tinggi dinding x total panjang dinding)x2 - Luas plesteran trasram

= ((3,9 x 230,22)x2)

= 1795,716 m²

7 Balok Latei

Balok Latei

Lantai 1

J1	14,85	m	P1	9,84	m
J2	15,8	m	P2	8,9	m
J3	13,35	m	P3	0	m
			P4	5,1	m
			P5	10	m
Total	77,84	m'			

2 Pasangan Dinding Bata merah t = 11 cm

Panjang dinding toilet = 77,8 m

Tinggi Dinding = 4,5-0,6 = 3,9 m

Luas dinding = (Tinggi dinding x panjang dinding)

= 77,8 x 3,9

= 302,42 m

4 Plesteran Mortar

Total panjang dinding = 230,22 m

Luas dinding = ((Tinggi dinding x total panjang dinding)x2) - Luas plesteran trasram

= ((3,9 x 230,22)x2) - 606,84

= 1188,876 m²

6 Kolom Praktis 11 x 11 cm

Jumlah Kolom praktis = 89 buah

Tinggi kolom = 4,5 m

Jadi, total panjang kolom praktis = 89 x 4,5 = 400,5 m

8 Sponengan

P1	21,36	m1
P2	18,96	m1
P3	0	m1
P4	15,96	m1
P5	20,48	m1
J1	39	m1
J2	60,48	m1
J3	9,2	m1
BV	19,1768	m1
Total	204,6168	m1

Karena 2 sisi maka dikalikan 2 = 409,2336 m

B LANTAI DUA

1 Pasangan Dinding Bata ringan t = 10 cm

Jenis	Panjang	Jumlah Kompo	Total
P1	9,1	17	149,09
P2	6,12	2	11,36
P3	7,9	1	7,68
P4	8,24	1	7,91
P5	8,95	3	25,75
P6	3,85	4	14,96
		Total	216,75

Tinggi Dinding = $4,5 - 0,6 = 3,9$ m

Luas area opening pintu dan jendela = 71,57 m²

Luas dinding = (Tinggi dinding x total panjang dinding) - Luas area opening jendela
 $= (3,9 \times 216,75) - 71,57$
 $= 773,755$ m²

3 Plesteran Trasram

Panjang dinding toilet = 38,9 m

Tinggi Dinding = $4,5 - 0,6 = 3,9$ m

Luas = (Tinggi dinding x panjang dinding) x 2
 $= 38,9 \times 3,9 \times 2$
 $= 303,42$ m²

5 Acian

Total panjang dinding = 216,75 m

Luas dinding = (Tinggi dinding x total panjang dinding)x2) - Luas plesteran trasram
 $= ((3,9 \times 216,75) \times 2) - 303,42$
 $= 1690,65$ m²

7 Balok Latei

Balok Latei

Lantai 2

J1	39,6	m	P1	6,56	m
J2	3,95	m	P2	8,9	m
J3	7	m	P3	2,6	m
			P4	0	m
			P5	5	m
Total	73,61	m'			

2 Pasangan Dinding Bata merah t = 11 cm

Panjang dinding toilet = 38,9 m

Tinggi Dinding = $4,5 - 0,6 = 3,9$ m

Luas dinding = (Tinggi dinding x panjang dinding)
 $= 38,9 \times 3,9$
 $= 151,71$ m²

4 Plesteran Mortar

Total panjang dinding = 216,75 m

Luas dinding = ((Tinggi dinding x total panjang dinding)x2) - Luas plesteran trasram
 $= ((3,9 \times 216,75) \times 2) - 303,42$
 $= 1387,23$ m²

6 Kolom Praktis 11 x 11 cm

Jumlah Kolom praktis = 80 buah

Tinggi kolom = 4,5 m

Jadi, total panjang kolom praktis = $80 \times 4,5 = 360$ m

8 Sponengan

P1	14,24	m1
P2	0	m1
P3	5,82	m1
P4	0	m1
P5	10,24	m1
J1	130	m1
J2	10,08	m1
J3	9,2	m1
BV	9,5884	m1
Total	189,1684	m1

Karena 2 sisi maka dikalikan 2 = 378,3368 m

II PEKERJAAN KUSEN PINTU / JENDELA , ASSESORIES & RAILING

A LANTAI SATU

1 Pembuatan dan Pemasangan Kusen Pintu ; Kusen Jendela

No	Tipe	Vol.Kusen (1)	Jumlah	Total vol
1	P1	0,06408	3	0,19224
2	P2	0,05688	3	0,17064
3	P3	0,05238	0	0
4	P4	0,04788	3	0,14364
5	P5	0,04608	4	0,18432
6	J1	0,06642	6	0,39852
7	J2	0,04536	12	0,54432
8	J3	0,0414	2	0,0828
9	BV	0,01944	8	0,15552
			Total	1,872

- 2 Pemasangan Pintu Tipe 1 + Assesories
Jumlah 3 Unit
- 3 Pemasangan Pintu Tipe 2 + Assesories
Jumlah 3 Unit
- 4 Pemasangan Pintu Tipe 4 + Assesories
Jumlah 3 Unit
- 5 Pemasangan Pintu Tipe 5 + Assesories
Jumlah 4 Unit
- 6 Pemasangan Jendela Tipe 1 + Assesories
Jumlah 6 Unit
- 7 Pemasangan Jendela Tipe 2 + Assesories
Jumlah 12 Unit
- 8 Pemasangan Jendela Tipe 3 + Assesories
Jumlah 2 Unit
- 9 Pemasangan Boven + Assesories
8 Unit

A LANTAI DUA

1 Pembuatan dan Pemasangan Kusen Pintu ; Kusen Jendela

No	Tipe	Vol.Kusen (1)	Jumlah	Total vol
1	P1	0,06408	2	0,12816
2	P2	0,05688	0	0
3	P3	0,05238	1	0,05238
4	P4	0,04788	0	0
5	P5	0,04608	2	0,09216
6	J1	0,06642	20	1,3284
7	J2	0,04536	2	0,09072

10 Finishing Melamin Kusen Daun Pintu ; Kusen Daun Jendela

No	Tipe	Vol.Kusen (1)	Jumlah	Total vol
1	P1	13,5456	3	40,6368
2	P2	10,0416	3	30,1248
3	P3	7,8516	0	0
4	P4	5,6616	3	16,9848
5	P5	4,7856	4	19,1424
6	J1	1,92014	6	11,52084
7	J2	1,28904	12	15,46848
8	J3	1,12668	2	2,25336
9	BV	1,1224	8	8,9792
			Total	145,11068 m ²

11 Fabrikasi dan Pemasangan Railing Tangga

	Panjang (m)	Jumlah(bh)	Total (m)
Tiang utama	1	21	21
Atas	17,06		17,06
Bawah	17,06		17,06
Tengah	0,65	49	31,85
		Jadi,	86,97 m

Karena ada 2 tangga maka, 86,97 x 2 = 173,94 m

8	J3	0,0414	2	0,0828
9	BV	0,01944	4	0,07776
			Total	1,85238

- 2 Pemasangan Pintu Tipe 1 + Assesories
Jumlah 2 Unit
- 3 Pemasangan Pintu Tipe 3 + Assesories
Jumlah 1 Unit
- 4 Pemasangan Pintu Tipe 5 + Assesories
Jumlah 2 Unit
- 5 Pemasangan Jendela Tipe 1 + Assesories
Jumlah 20 Unit
- 6 Pemasangan Jendela Tipe 2 + Assesories
Jumlah 2 Unit
- 7 Pemasangan Jendela Tipe 3 + Assesories
Jumlah 2 Unit
- 8 Pemasangan Boven + Assesories
4 Unit

9 Finishing Melamin Kusen Daun Pintu ; Kusen Daun Jendela

No	Tipe	Vol.Kusen (l)	Jumlah	Total vol
1	P1	13,5456	2	27,0912
2	P2	10,0416	0	0
3	P3	7,8516	1	7,8516
4	P4	5,6616	0	0
5	P5	4,7856	2	9,5712
6	J1	1,92014	20	38,4028
7	J2	1,28904	2	2,57808
8	J3	1,12668	2	2,25336
9	BV	1,1224	4	4,4896
			Total	92,23784 m ²

10 Fabrikasi dan Pemasangan Railing Tangga

> Tampak Selatan (Tidak termasuk bagian Balkon)

	Panjang (m)	Jumlah(bh)	Total (m)
Tiang utama	1	44	44
Atas	42,5		42,5
Bawah	42,5		42,5
Tengah	0,65	176	114,4
		Jadi,	243,4 m

> Tampak Utara (Tidak termasuk bagian Balkon)

	Panjang (m)	Jumlah(bh)	Total (m)
--	-------------	------------	-----------

> Tampak Timur (Tidak termasuk bagian Balkon)

	Panjang (m)	Jumlah(bh)	Total (m)
Tiang utama	1	24	24
Atas	23,19		23,19
Bawah	23,19		23,19
Tengah	0,65	92	59,8
		Jadi,	130,18 m

> Tampak Barat (Tidak termasuk bagian Balkon)

	Panjang (m)	Jumlah(bh)	Total (m)
Tiang utama	1	24	24
Atas	23,19		23,19
Bawah	23,19		23,19
Tengah	0,65	92	59,8
		Jadi,	130,18 m

> Balkon

Utara	Panjang (m)	Jumlah(bh)	Total (m)
Tiang utama	11	8	88
Atas	10,9		10,9
Bawah	10,9		10,9
Tengah	0,65	11	7,15
		Jadi,	116,95 m

Timur	Panjang (m)	Jumlah(bh)	Total (m)
Tiang utama	1	8	8
Atas	8,8		8,8
Bawah	8,8		8,8
Tengah	0,65	8	5,2
		Jadi,	30,8 m

Barat	Panjang (m)	Jumlah(bh)	Total (m)
Tiang utama	1	8	8
Atas	8,8		8,8
Bawah	8,8		8,8
Tengah	0,65	8	5,2
		Jadi,	30,8 m

TOTAL 925,71 m

Tiang utama	1	44	44
Atas	42,5		42,5
Bawah	42,5		42,5
Tengah	0,65	176	114,4
		Jadi,	243,4

m

III PEKERJAAN PLAFOND

A LANTAI SATU

1 Rangka hollow galvanis 40x40x3 mm

Kantor Bidang Mechanical	155,5547	m2
R. Rapat	87,1754	m2
R. Direksi	87,1754	m2
Lobby	98,0418	m2
ATM center & Informatika	87,6205	m2
Penerimaan Tamu	87,4658	m2
Selasar (dalam)	98,2581	m2
Locker room	57,8419	m2
Ruang CCTV	57,5497	m2
Tangga	22,33	
Area tangga (timur)	38,1219	m2
Selasar (Luar)	322,5580357	m2
Total	1199,693236	m2
Balkon	90	m2
	1290	m2

2 Penutup plafond Gypsum t=9 mm

Rangka hollow - luas keramik toilet = $1290 - 75 = 1215 \text{ m}^2$

3 Penutup Plafond PVC t = 8 mm

Luas keramik toilet = 75 m^2

4 List Plafond Gypsum 8 cm

Lantai 1

Kantor Bidang Mechanical	65	m'
R. Rapat	39,3	m'
R. Direksi	39,6	m'
Lobby	19,5	m'
ATM center & Informatika	28,2	m'
Penerimaan Tamu	37,6	m'
Selasar (dalam)	19,5	m'
Locker room	23,5	m'
Ruang CCTV	31	m'
Area tangga (timur)	27,2	m'
Selasar (Luar)	0	m'
Toilet (barat)	34	m'

B LANTAI DUA

1 Rangka hollow galvanis 40x40x3 mm

Smoking room	37,94	m2
Kantor Bidang	141,2227	m2
Kantor Bidang	98,5116	m2
Kantor keuangan	58,5	m2
R. Santai	97,887	m2
R. Rapat Pegawai	97,07	m2
Kantor Bidang	97,5825	m2
Kantor operasi	294,8058	m2
Selasar (luar)	205,1586	m2
	1.129	m2
Tritisian	58,332	m2
Total	1.187	m2

2 Penutup plafond Gypsum t=9 mm

Rangka hollow - luas keramik toilet = $1187 - 37 = 1150 \text{ m}^2$

3 Penutup Plafond PVC t = 8 mm

Luas keramik toilet = 37 m^2

4 List Plafond Gypsum 8 cm

Lantai 2

Smoking room	27,5	m'
Kantor Bidang	47,6	m'
Kantor Bidang	13,1	m'
Kantor keuangan	19,4	m'
R. Santai	32,9	m'
R. Rapat Pegawai	37,6	m'
Kantor Bidang	28,2	m'
Kantor operasi	47	m'
Selasar (luar)	0	m'
Dinding dalam	9,4	m'
Toilet (timur)	34	m'
Total	263	m'

5 List Plafond PVC 8 cm

Toilet (barat) 34 m'

Toilet (timur)	34	m'
Total	330	m'

5 List Plafond PVC 8 cm

Toilet (barat)	34	m'
Toilet (timur)	34	m'
Total	68	m'

IV PEKERJAAN KERAMIK LANTAI & DINDING

A LANTAI SATU

1 Pasang Keramik Lantai 60 x 60 (Polished)

Kantor Bidang Mechanical	156	m2
R. Rapat	87,1754	m2
R. Direksi	87,1754	m2
Lobby	98,0418	m2
ATM center & Informatika	87,6205	m2
Penerimaan Tamu	87,4658	m2
Selasar (dalam)	98,2581	m2
Locker room	57,8419	m2
Ruang CCTV	57,5497	m2
Tangga	22,33	
Area tangga (timur)	38,1219	m2
	322,558	m2
	1.200	m2
Polished	877,135	m2

2 Pasang Keramik Lantai 60 x 60 (Unpolished)
Selasar (Luar) 323 m2

3 Pasang Keramik Lantai 30 x 30 km/wc

Toilet (barat)	37	m2
Toilet (timur)	37	m2
Total	75	m2

4 Pasang Keramik dinding 30 x 60 km/wc
Lantai 1

Toilet (barat)	68	m2
Toilet (timur)	68	m2
Total	136	m2

5 Pasang Plint Keramik 10 x 60 cm

Lantai 1		
Kantor Bidang Mechanical	60	m'
R. Rapat	37,3	m'
R. Direksi	36,5	m'
Lobby	16,5	m'

6 Pasang Stepnosing Tangga 10 x 60 cm
Stepnosing tangga 46,5 m'

B LANTAI DUA

1 Pasang Keramik Lantai 60 x 60 (Polished)

Smoking room	37,94	m2
Kantor Bidang	141,2227	m2
Kantor Bidang	98,5116	m2
Kantor keuangan	58,5	m2
R. Santai	97,887	m2
R. Rapat Pegawai	97,07	m2
Kantor Bidang	97,5825	m2
Kantor operasi	294,8058	m2
Total	924	m2

2 Pasang Keramik Lantai 60 x 60 (Unpolished)
Selasar (Luar) 295 m2

3 Pasang Keramik Lantai 30 x 30 km/wc
Toilet (timur) 37 m2

4 Pasang Keramik dinding 30 x 60 km/wc
Lantai 2
Toilet (timur) 68 m2

5 Pasang Plint Keramik 10 x 60 cm
Lantai 2

Smoking room	26	m'
Kantor Bidang	46,1	m'
Kantor Bidang	13,1	m'
Kantor keuangan	17,8	m'
R. Santai	32,9	m'
R. Rapat Pegawai	34,6	m'
Kantor Bidang	25,2	m'
Kantor operasi	47	m'
Dinding dalam	6,4	m'

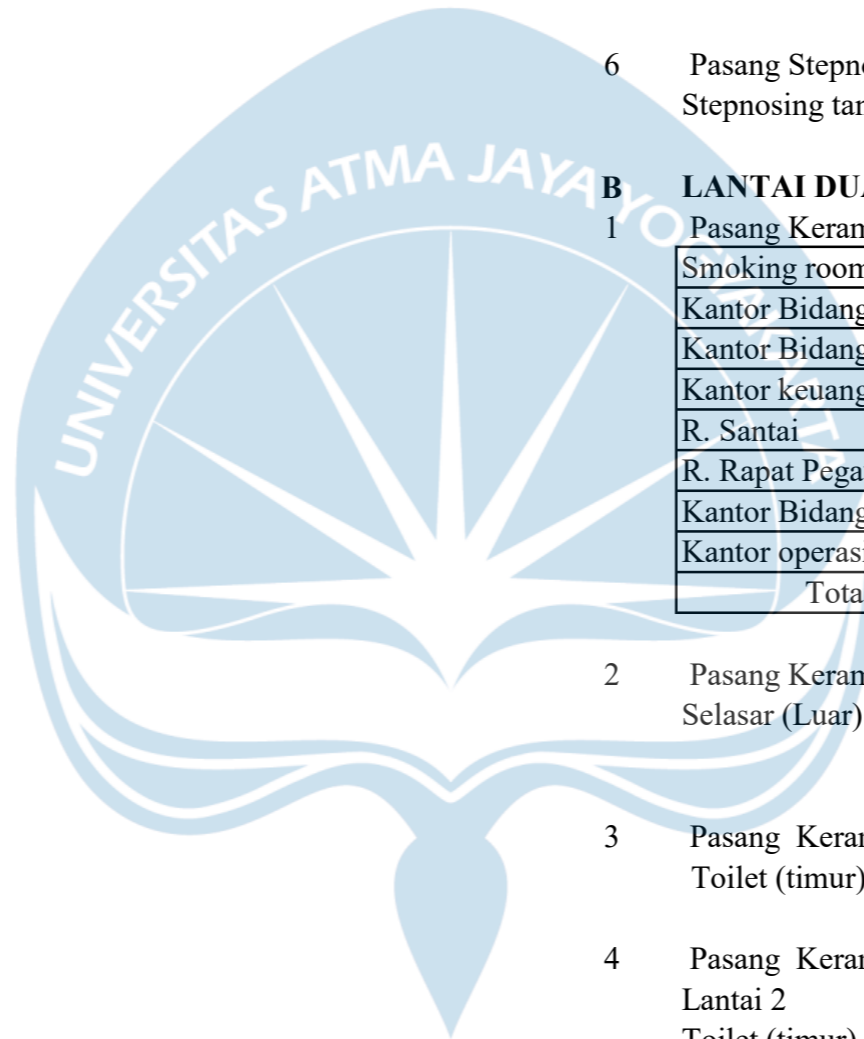

ATM center & Informati	28,2	m'
Penerimaan Tamu	34,6	m'
Selasar (dalam)	19,5	m'
Locker room	23,5	m'
Ruang cctv	30	m'
Area tangga (timur)	25,1	m'
Total	311	m'

Total	249	m'
-------	-----	----

V PEKERJAAN SANITAIR

A LANTAI SATU

Lantai 1

Pasang Closet Duduk (Le	14	Buah
Pasang Urinoir (Lengkap	6	Buah
Pasang Partisi Urinoir	4	Buah
Pasang Cermin - Toilet	9,6	M2
Pasang Wastafel - Toilet	12	Buah
Pasang Jet Washer - Toile	14	Buah
Pasang Floor Drain Stainl	14	Buah
Pasang Partisi Toilet	68,292	M2

B LANTAI DUA

Lantai 2

Pasang Closet Duduk (Le	7	Buah
Pasang Urinoir (Lengkap	3	Buah
Pasang Partisi Urinoir	2	Buah
Pasang Cermin - Toilet	4,8	M2
Pasang Wastafel - Toilet	6	Buah
Pasang Jet Washer - Toile	7	Buah
Pasang Floor Drain Stainl	7	Buah
Pasang Partisi Toilet	34,146	M2

VI PEKERJAAN PENGECATAN

A LANTAI SATU

1 Cat dinding bag. Luar termasuk kolom/balok, Drop Area (exterior) Tipe Wheatershield

Utara	185,2	m2
Timur	74,08	m2
Selatan	188,4	m2
Barat	74,08	m2
Kolom	81,69714286	m2
Balok Lisplang	160,835	m2
Opening Pintu dan Jendel	83,676	m2
	717,656	m2

Ruang cctv	108,5	m2
Area tangga (ti	95,2	m2
Toilet (barat)	30,6	m2
Toilet (timur)	30,6	m2
Kolom	40,25	m2
Opening Pintu	83,676	m2
	1174,174	m2

3 Cat Plafond Gypsum Tipe Acrilic emultion paint

Lantai 1 1.139,83 m2

4 Cat Railing Tangga, Dulux V-Gloss

Lantai 1 13,9152 m2

B LANTAI DUA

1 Cat dinding bag. Luar termasuk kolom/balok (exterior) Tipe Wheatershield

Utara	185,2	m2
Timur	74,08	m2
Selatan	188,4	m2
Barat	74,08	m2
Kolom	66,96	m2
Opening Pintu	71,57	m2
	517,15	m2

2 Cat dinding bag. Dalam termasuk kolom/balok (interior) Tipe Acrilic emultion paint

Lantai 2

Smoking room	96,25	m2
Kantor Bidang	166,6	m2
Kantor Bidang	45,85	m2
Kantor keuangan	67,9	m2
R. Santai	115,15	m2
R. Rapat Pegawai	131,6	m2
Kantor Bidang	98,7	m2
Kantor operasi	164,5	m2

2 Cat dinding bag. Dalam termasuk kolom/balok (interior) Tipe Acrilic emultion paint

Kantor Bidang Mechanical	227,5	m2
R. Rapat	137,55	m2
R.Direksi	138,6	m2
Lobby	68,25	m2
ATM center & Informatika	98,7	m2
Penerimaan Tamu	131,6	m2
Selasar (dalam)	68,25	m2
Locker room	82,25	m2

Dinding dalam	32,9	m2
Toilet (timur)	30,6	m2
Kolom	43,05	m2
Opening Pintu	71,57	m2
Total	921,53	m2

3 Cat Plafond Gypsum Tipe Acrilic emultion paint

Lantai 2 1.112 m2

4 Cat Railing Selasar + Balkon, Dulux V-Gloss

Lantai 2 148 m2



Lampiran B.5. Rekap Kebutuhan Pekerja

No	URAIAN PEKERJAAN	SATUAN	VOLUME	DURASI	SUMBER DAYA	RESOURCE
I	PEKERJAAN PERSIAPAN					
1	Pembersihan Lahan	m2	4060,00	6,00	Pekerja Mandor Batu	33,83 3,38
2	Pekerjan perataan tanah (Galian)	m2	1586,27	4,00	Excavator PC.75 Cap 0.3 m3 Dump Truck	2,75 1,72
3	Pekerjaan pemadatan tanah	m3	32,52	1,00	Pekerja Mandor Batu Mesin Stamper 250 kg	1,45 0,15 0,73
4	Direksi Keet	m2	120,00	7,00	Pekerja Tukang Batu Kepala Tukang Batu Mandor Batu	20,57 6,86 0,69 2,06
5	pekerjaan pagar keliling	m'	256,00	7,00	Pekerja Tukang Kayu Kepala Tukang Kayu Mandor Kayu	14,63 7,31 0,73 0,73
6	papan nama proyek + foto	ls				
7	pekerjaan bowplank	m	168,00	7,00	Pekerja Tukang Kayu Kepala Tukang Kayu Mandor Kayu	2,40 2,40 0,24 0,12
8	Air Kerja	ls				
9	Listrik Kerja	ls				
II	PEKERJAAN GALIAN					
1	Pekerjaan Galian	M3	530,63364	2,00	Excavator PC.75 Cap 0.3 m3 Dump Truck	1,84 1,15
2	Pekerjaan Urugan Pasir tebal 10 cm (Pilecap):	M3	16,50896	1,00	Pekerja Mandor Batu	4,95 0,17
3	Pekerjaan Lantai Kerja tebal 5 cm (Pilecap):	M3	8,25	1,00	Pekerja Kepala Tukang Batu Tukang Batu Mandor	8,25 0,21 2,06 0,83

					Molen (0.35 m3)	1,96
4	Pekerjaan Urugan Pasir tebal 10 cm (Sloof):	M3	43,26892	1,00	Pekerja	12,98
					Mandor Batu	0,43
5	Pekerjaan Lantai Kerja tebal 5 cm (Sloof):	M3	21,63	1,00	Pekerja	21,63
					Kepala Tukang Batu	0,54
					Tukang Batu	5,41
					Mandor	2,16
					Molen (0.35 m3)	5,15
6	Pekerjaan Urugan tanah Kembali bekas galian (Pilecap)	M3	383,74	1,00	Pekerja	38,37
					Mandor Batu	3,84
II PEKERJAAN STRUKTUR BAWAH						
A PEKERJAAN PONDASI						
1	Pekerjaan Tiang Pancang 60 cm	buah	60,00	7,00	Pekerja	34,30
					Tukang Batu	6,86
					Mandor Batu	3,44
					Alat Pancang HSPD 420 (Tekanan maksimum 420 ton; Spun Pile Uk. 300 - 600 mm)	0,99
B PEKERJAAN PILECAP						
1	Pekerjaan Beton	m3	81,33	2,00	Pekerja	23,59
					Kepala Tukang Batu	0,41
					Tukang Batu	4,07
					Mandor	2,36
					Pompa beton Ø 2,5", 75KW; 120 bar, T= 30 m'	1,63
					Concrete Vibrator φ 45 mm; 10 HP	3,25
2	Pekerjaan Pembesian	100 kg	94,99	1,00	Pekerja	15,20
					Tukang Besi	7,60
					Kepala Tukang Besi	0,76
					Mandor	1,52
					Mesin Potong Besi (Uk. 6-32 mm ; Berat 300 kg; Tegangan 2500-6600 watt)	3,80
					Bender Besi (Uk. 6-32 mm ; Berat 300 kg; Tegangan 2500-6600 watt)	3,80
3	Pekerjaan Bekisting	M2	178,88	2,00	Pekerja	17,89
					Tukang kayu	8,94
					Kepala Tukang kayu	0,89
					Mandor	1,79
C PEKERJAAN TIE BEAM						

1	Pekerjaan Beton	m3	30,44	1,00	Pekerja	17,65
					Kepala Tukang Batu	0,30
					Tukang Batu	3,04
					Mandor	1,77
					Pompa beton Ø 2,5", 75KW; 120 bar, T= 30 m'	1,22
					Concrete Vibrator φ 45 mm; 10 HP	2,44
2	Pekerjaan Pembesian	100 kg	50,67	1,00	Pekerja	8,11
					Tukang Besi	4,05
					Kepala Tukang Besi	0,41
					Mandor	0,81
					Mesin Potong Besi (Uk. 6-32 mm ; Berat 300 kg; Tegangan 2500-6600 watt)	2,03
					Bender Besi (Uk. 6-32 mm ; Berat 300 kg; Tegangan 2500-6600 watt)	2,03
3	Pekerjaan Bekisting	M2	317,45	2,00	Pekerja	31,75
					Tukang kayu	15,87
					Kepala Tukang kayu	1,59
					Mandor	3,17
D	PEKERJAAN KOLOM PEDESTAL					
1	Pekerjaan Beton	M3	14,42	1,00	Pekerja	8,36
					Kepala Tukang Batu	0,14
					Tukang Batu	1,44
					Mandor	0,84
					Pompa beton Ø 2,5", 75KW; 120 bar, T= 30 m'	0,58
					Concrete Vibrator φ 45 mm; 10 HP	1,15
2	Pekerjaan Pembesian	100 Kg	50,67	1,00	Pekerja	8,11
					Tukang Besi	4,05
					Kepala Tukang Besi	0,41
					Mandor	0,81
					Mesin Potong Besi (Uk. 6-32 mm ; Berat 300 kg; Tegangan 2500-6600 watt)	2,03
					Bender Besi (Uk. 6-32 mm ; Berat 300 kg; Tegangan 2500-6600 watt)	2,03
3	Pekerjaan Bekisting	M2	73,51	1,00	Pekerja	24,99
					Tukang kayu	12,50
					Kepala Tukang kayu	1,25
					Mandor	2,50
III	PEKERJAAN STRUKTUR ATAS					
A	PEKERJAAN LANTAI DASAR					
A1	PEKERJAAN KOLOM					

1	Pekerjaan Beton	M3	41,70	1,00	Pekerja	24,19
					Kepala Tukang Batu	0,42
					Tukang Batu	4,17
					Mandor	2,42
					Pompa beton Ø 2,5", 75KW; 120 bar, T= 30 m'	1,67
					Concrete Vibrator φ 45 mm; 10 HP	3,34
2	Pekerjaan Pembesian	100 Kg	122,19	2,00	Pekerja	9,78
					Tukang Besi	4,89
					Kepala Tukang Besi	0,49
					Mandor Besi	0,98
					Mesin Potong Besi (Uk. 6-32 mm ; Berat 300 kg; Tegangan 2500-6600 watt)	2,44
					Bender Besi (Uk. 6-32 mm ; Berat 300 kg; Tegangan 2500-6600 watt)	2,44
3	Pekerjaan Bekisting	M2	220,54	3,00	Pekerja	24,99
					Tukang Kayu	12,50
					Kepala Tukang Kayu	1,25
					Mandor Kayu	2,50
A.2	PEKERJAAN LANTAI					
1	Pekerjaan Urugan Pasir 10 cm	M3	152,64	4,00	Pekerja	11,45
					Mandor Batu	0,38
2	Pekerjaan Cor Beton 15 MPa 5 cm	M3	152,64	4,00	Pekerja	22,13
					Kepala Tukang Batu	0,38
					Tukang Batu	3,82
					Mandor Batu	2,21
					Pompa beton Ø 2,5", 75KW; 120 bar, T= 30 m'	1,53
					Concrete Vibrator φ 45 mm; 10 HP	3,05
A.3	PEKERJAAN KOLOM, BALOK BORDES, DAN TANGGA					
1	Pekerjaan Beton	M3	13,51	2,00	Pekerja	3,92
					Kepala Tukang Batu	0,07
					Tukang Batu	0,68
					Mandor	0,39
					Pompa beton Ø 2,5", 75KW; 120 bar, T= 30 m'	0,27
					Concrete Vibrator φ 45 mm; 10 HP	0,54
2	Pekerjaan Pembesian	100 Kg	9,50	1,00	Pekerja	1,52
					Tukang Besi	0,76
					Kepala Tukang Besi	0,08
					Mandor Besi	0,15
					Mesin Potong Besi (Uk. 6-32 mm ; Berat 300 kg; Tegangan 2500-6600 watt)	0,38

					Bender Besi (Uk. 6-32 mm ; Berat 300 kg; Tegangan 2500-6600 watt)	0,38
3	Pekerjaan Bekisting					
a	Kolom KB (Samping kanan & kiri))	M2	10,80	2,00	Pekerja	1,84
					Tukang Kayu	0,92
					Kepala Tukang Kayu	0,09
					Mandor Kayu	0,18
b	Balok Bordes 20x40 cm	M2	6,60	2,00	Pekerja	1,19
					Tukang Kayu	1,19
					Kepala Tukang Kayu	0,12
					Mandor Kayu	0,12
c	Tangga lt. 1 (Kiri dan Kanan)	M2	73,12	2,00	Pekerja	13,16
					Tukang Kayu	13,16
					Kepala Tukang Kayu	1,32
					Mandor Kayu	1,32
B	PEKERJAAN LANTAI 2					
B.1	PEKERJAAN KOLOM					
1	Pekerjaan Beton	M3	30,66	1,00	Pekerja	17,78
					Kepala Tukang Batu	0,31
					Tukang Batu	3,07
					Mandor	1,78
					Pompa beton Ø 2,5", 75KW; 120 bar, T= 30 m'	1,23
					Concrete Vibrator φ 45 mm; 10 HP	2,45
2	Pekerjaan Pembesian	100 Kg	90,15	2,00	Pekerja	7,21
					Tukang Besi	3,61
					Kepala Tukang Besi	0,36
					Mandor Besi	0,72
					Mesin Potong Besi (Uk. 6-32 mm ; Berat 300 kg; Tegangan 2500-6600 watt)	1,80
					Bender Besi (Uk. 6-32 mm ; Berat 300 kg; Tegangan 2500-6600 watt)	1,80
3	Pekerjaan Bekisting	M2	169,65	2,00	Pekerja	28,84
					Tukang Kayu	14,42
					Kepala Tukang Kayu	1,44
					Mandor Kayu	2,88
B.2	PEKERJAAN BALOK					
1	Pekerjaan Beton	M3	151,19	6,00	Pekerja	14,61
					Kepala Tukang Batu	0,25
					Tukang Batu	2,52

					Mandor	1,46
					Pompa beton Ø 2,5", 75KW; 120 bar, T= 30 m'	1,01
					Concrete Vibrator φ 45 mm; 10 HP	2,02
2	Pekerjaan Pembesian	100 Kg	344,02	27,00	Pekerja	2,04
					Tukang Besi	1,02
					Kepala Tukang Besi	0,10
					Mandor Besi	0,20
					Mesin Potong Besi (Uk. 6-32 mm ; Berat 300 kg; Tegangan 2500-6600 watt)	0,51
					Bender Besi (Uk. 6-32 mm ; Berat 300 kg; Tegangan 2500-6600 watt)	0,51
3	Pekerjaan Bekisting	M2	1158,63	27,00	Pekerja	15,45
					Tukang Kayu	15,45
					Kepala Tukang Kayu	1,54
					Mandor Kayu	1,54
B.3	PEKERJAAN PELAT LANTAI					
1	Pekerjaan Beton	M3	125,42	6,00	Pekerja	12,12
					Kepala Tukang Batu	0,21
					Tukang Batu	2,09
					Mandor	1,21
					Pompa beton Ø 2,5", 75KW; 120 bar, T= 30 m'	0,84
					Concrete Vibrator φ 45 mm; 10 HP	1,67
2	Pekerjaan Pembesian	100 Kg	97,35	27,00	Pekerja	0,29
					Tukang Besi	0,14
					Kepala Tukang Besi	0,01
					Mandor Besi	0,03
					Mesin Potong Besi (Uk. 6-32 mm ; Berat 300 kg; Tegangan 2500-6600 watt)	0,14
					Bender Besi (Uk. 6-32 mm ; Berat 300 kg; Tegangan 2500-6600 watt)	0,14
3	Pekerjaan Bekisting	M2	1068,90	27,00	Pekerja	19,79
					Tukang Kayu	9,90
					Kepala Tukang Kayu	0,99
					Mandor Kayu	1,98
C	PEKERJAAN ATAP					
C.1	PEKERJAAN RING BALOK					
1	Pekerjaan Beton	M3	21,02	2,00	Pekerja	6,10
					Kepala Tukang Batu	0,11
					Tukang Batu	1,05
					Mandor	0,61
					Pompa beton Ø 2,5", 75KW; 120 bar, T= 30 m'	0,42

					Concrete Vibrator ϕ 45 mm; 10 HP	0,84
2	Pekerjaan Pembesian	100 Kg	27,28	3,00	Pekerja	1,45
					Tukang Besi	0,73
					Kepala Tukang Besi	0,07
					Mandor Besi	0,15
					Mesin Potong Besi (Uk. 6-32 mm ; Berat 300 kg; Tegangan 2500-6600 watt)	0,36
					Bender Besi (Uk. 6-32 mm ; Berat 300 kg; Tegangan 2500-6600 watt)	0,36
3	Pekerjaan Bekisting	M2	181,30	4,00	Pekerja	16,32
					Tukang Kayu	16,32
					Kepala Tukang Kayu	1,63
					Mandor Kayu	1,63
C.2	PEKERJAAN ATAP					
1	Perakitan Kuda-Kuda (2L50)	Kg	4972,89	28,00	Pekerja	10,66
					Tukang Besi	10,66
					Kepala Tukang Besi	1,07
					Mandor Besi	0,53
2	Perakitan Kuda-Kuda (2L60)	Kg	3636,79	28,00	Pekerja	7,79
					Tukang Besi	7,79
					Kepala Tukang Besi	0,78
					Mandor Besi	0,39
3	Instalasi Ikatan Angin	Kg	378,72	2,00	Pekerja	11,36
					Tukang Besi	11,36
					Kepala Tukang Besi	1,14
					Mandor Besi	0,57
4	Instalasi Gording	Kg	5500,80	19,00	Pekerja	17,37
					Tukang Besi	17,37
					Kepala Tukang Besi	1,74
					Mandor Besi	0,87
5	Instalasi Sagrod	Kg	246,80	1,00	Pekerja	14,81
					Tukang Besi	14,81
					Kepala Tukang Besi	1,48
					Mandor Besi	0,74
6	Instalasi Usuk	Kg	1702,00	8,00	Pekerja	12,77
					Tukang Besi	12,77
					Kepala Tukang Besi	1,28
					Mandor Besi	0,64

7	Instalasi Reng	Kg	1647,00	8,00	Pekerja	12,35
					Tukang Besi	12,35
					Kepala Tukang Besi	1,24
					Mandor Besi	0,62
8	Pemasangan Atap sirap	m2	1489,75	18,00	Pekerja	13,74
					Tukang Kayu	20,69
					Kepala Tukang Kayu	2,07
					Mandor Kayu	0,66
IV	PEKERJAAN ARSITEKTUR					
I	PEKERJAAN PASANGAN DINDING & BETON PRAKTIS					
A	LANTAI SATU					
1	Pasangan Dinding Bata ringan t = 10 cm	M2	814,182	35	Pekerja	13,96
					Tukang Batu	3,02
					Kepala Tukang Batu	0,30
					Mandor Batu	0,07
2	Pasangan Dinding Bata merah t = 11 cm	M2	303,42	35	Pekerja	5,20
					Tukang Batu	1,73
					Kepala Tukang Batu	0,17
					Mandor Batu	0,17
3	Plesteran Trasram	M2	606,84	23	Pekerja	4,22
					Tukang Batu	4,22
					Kepala Tukang Batu	0,42
					Mandor Batu	0,42
4	Plesteran Mortar	M2	1188,876	23	Pekerja	9,82
					Tukang Batu	9,82
					Kepala Tukang Batu	0,98
					Mandor Batu	0,98
5	Acian	M2	1795,716	23	Pekerja	7,81
					Tukang Batu	7,81
					Kepala Tukang Batu	0,78
					Mandor Batu	0,78
6	Kolom Praktis 11 x 11 cm	M'	400,5	35	Pekerja	2,06
					Tukang Batu	0,23
					Tukang Kayu	0,23
					Tukang Besi	0,23
					Mandor Batu	0,10
					Mandor Kayu	0,10
7	Balok Latei	M'	77,84	35	Pekerja	0,40
					Tukang Batu	0,04

					Tukang Kayu	0,04
					Tukang Besi	0,04
					Mandor Batu	0,02
					Mandor Kayu	0,02
8	Sponengan	M'	409,2336	5	Pekerja	4,67
					Tukang Batu	3,11
					Kepala Tukang Batu	0,31
					Mandor Batu	0,16
B	LANTAI DUA					
1	Pasangan Dinding Bata Ringan t = 10 cm	M2	773,755	41	Pekerja	11,32
					Tukang Batu	2,45
					Kepala Tukang Batu	0,25
					Mandor Batu	0,06
2	Pasangan Dinding Bata merah t = 11 cm	M2	151,71	41	Pekerja	2,22
					Tukang Batu	0,74
					Kepala Tukang Batu	0,07
					Mandor Batu	0,07
3	Plesteran Trasram	M2	303,42	48	Pekerja	1,01
					Tukang Batu	1,01
					Kepala Tukang Batu	0,10
					Mandor Batu	0,10
4	Plesteran Mortar	M2	1387,23	48	Pekerja	5,49
					Tukang Batu	5,49
					Kepala Tukang Batu	0,55
					Mandor Batu	0,55
5	Acian	M2	1690,65	48	Pekerja	3,52
					Tukang Batu	3,52
					Kepala Tukang Batu	0,35
					Mandor Batu	0,35
6	Kolom Praktis 11 x 11 cm	M'	360	41	Pekerja	1,58
					Tukang Batu	0,18
					Tukang Kayu	0,18
					Tukang Besi	0,18
					Mandor Batu	0,08
					Mandor Kayu	0,08
7	Balok Latei	M'	73,61	41	Pekerja	0,32
					Tukang Batu	0,04
					Tukang Kayu	0,04
					Tukang Besi	0,04
					Mandor Batu	0,02

					Mandor Kayu	0,02
8	Sponengan	M'	378,3368	5	Pekerja	4,31
					Tukang Batu	2,88
					Kepala Tukang Batu	0,29
					Mandor Batu	0,15
II	PEKERJAAN KUSEN PINTU / JENDELA , ASSESORIES & RAILING					
A	LANTAI SATU					
1	Pembuatan dan Pemasangan Kusen Pintu ; Kusen Jendela	M3	1,872	35	Pekerja	0,37
					Tukang Kayu	1,12
					Kepala Tukang Kayu	0,11
					Mandor Kayu	0,02
2	Pemasangan Pintu Tipe 1 + Assesories	Unit	3	3	Pekerja	0,19
					Tukang Kayu	0,19
					Kepala Tukang Kayu	0,04
					Mandor Kayu	0,01
3	Pemasangan Pintu Tipe 2 + Assesories	Unit	3	3	Pekerja	0,19
					Tukang Kayu	0,19
					Kepala Tukang Kayu	0,04
					Mandor Kayu	0,01
4	Pemasangan Pintu Tipe 4 + Assesories	Unit	3	3	Pekerja	0,10
					Tukang Kayu	0,10
					Kepala Tukang Kayu	0,02
					Mandor Kayu	0,01
5	Pemasangan Pintu Tipe 5 + Assesories	Unit	4	3	Pekerja	0,13
					Tukang Kayu	0,13
					Kepala Tukang Kayu	0,03
					Mandor Kayu	0,01
6	Pemasangan Jendela Tipe 1 + Assesories	Unit	6	3	Pekerja	1,03
					Tukang Kayu	1,30
					Kepala Tukang Kayu	0,13
					Mandor Kayu	0,07
7	Pemasangan Jendela Tipe 2 + Assesories	Unit	12	3	Pekerja	2,06
					Tukang Kayu	2,60
					Kepala Tukang Kayu	0,26
					Mandor Kayu	0,13
8	Pemasangan Jendela Tipe 3 + Assesories	Unit	2	3	Pekerja	0,34

					Tukang Kayu	0,43
					Kepala Tukang Kayu	0,04
					Mandor Kayu	0,02
9	Pemasangan Boven + Assesories	Unit	8	3	Pekerja	1,40
					Tukang Kayu	2,00
					Kepala Tukang Kayu	0,20
					Mandor Kayu	0,09
10	Finishing Melamin Kusen Daun Pintu ; Kusen Daun Jendela	M2	145,11068	11	Pekerja	6,60
					Tukang Kayu	6,60
					Kepala Tukang Kayu	0,66
					Mandor Kayu	0,33
11	Fabrikasi dan Pemasangan Railing Tangga	M'	173,94	1	Pekerja	4,87
					Tukang Besi	10,44
					Kepala Tukang Besi	1,04
					Mandor Besi	0,35
					Sewa Alat Welding (Minimal 5 Jam)	4,57
B	LANTAI DUA					
1	Pembuatan dan Pemasangan Kusen Pintu ; Kusen Jendela	M3	1,85238	41	Pekerja	0,32
					Tukang Kayu	0,95
					Kepala Tukang Kayu	0,09
					Mandor Kayu	0,02
2	Pemasangan Pintu Tipe 1 + Assesories	Unit	2	3	Pekerja	0,13
					Tukang Kayu	0,13
					Kepala Tukang Kayu	0,03
					Mandor Kayu	0,01
3	Pemasangan Pintu Tipe 3 + Assesories	Unit	1	3	Pekerja	0,03
					Tukang Kayu	0,03
					Kepala Tukang Kayu	0,01
					Mandor Kayu	0,00
4	Pemasangan Pintu Tipe 5 + Assesories	Unit	2	3	Pekerja	0,06
					Tukang Kayu	0,06
					Kepala Tukang Kayu	0,01
					Mandor Kayu	0,00
5	Pemasangan Jendela Tipe 1 + Assesories	Unit	20	3	Pekerja	3,43
					Tukang Kayu	4,33
					Kepala Tukang Kayu	0,43
					Mandor Kayu	0,22

6	Pemasangan Jendela Tipe 2 + Assesories	Unit	2	3	Pekerja	0,34
					Tukang Kayu	0,43
					Kepala Tukang Kayu	0,04
					Mandor Kayu	0,02
7	Pemasangan Jendela Tipe 3 + Assesories	Unit	2	3	Pekerja	0,34
					Tukang Kayu	0,43
					Kepala Tukang Kayu	0,04
					Mandor Kayu	0,02
8	Pemasangan Boven + Assesories	Unit	4	3	Pekerja	0,70
					Tukang Kayu	1,00
					Kepala Tukang Kayu	0,10
					Mandor Kayu	0,04
9	Finishing Melamin Kusen Daun Pintu ; Kusen Daun Jendela	M2	92,23784	4	Pekerja	11,53
					Tukang Kayu	11,53
					Kepala Tukang Kayu	1,15
					Mandor Kayu	0,58
10	Fabrikasi dan Pemasangan Railling Selasar + Balkon, Hollow 40 x 40 x 1,2 mm	M'	925,71	3	Pekerja	8,64
					Tukang Besi	18,51
					Kepala Tukang Besi	1,85
					Mandor Besi	0,62
					Sewa Alat Welding (Minimal 5 Jam)	8,10
III	PEKERJAAN PLAFOND					
A	LANTAI SATU					
1	Penutup plafond Gypsum t =9 mm	M2	1214,759236	7	Pekerja	17,35
					Tukang Kayu	8,68
					Kepala Tukang Kayu	0,87
					Mandor Kayu	0,87
2	Penutup Plafond PVC t = 8 mm	M2	74,934	7	Pekerja	1,61
					Tukang Kayu	2,68
					Kepala Tukang Kayu	0,27
					Mandor Kayu	0,80
3	Rangka hollow galvanis 40x40x3 mm	M2	1289,693236	23	Pekerja	19,63
					Tukang Besi	19,63
					Kepala Tukang Besi	1,96
					Mandor Besi	1,01
4	List Plafond Gypsum 8 cm	M'	330,4	2	Pekerja	9,91
					Tukang Kayu	9,91

					Kepala Tukang Kayu	0,99
					Mandor Kayu	0,50
5	List Plafond PVC 8 cm	M'	68	2	Pekerja	3,40
					Tukang Kayu	1,70
					Kepala Tukang Kayu	0,17
					Mandor Kayu	0,17
B	LANTAI DUA					
1	Penutup plafond Gypsum t=9	M2	1149,5432	5	Pekerja	22,99
					Tukang Kayu	11,50
					Kepala Tukang Kayu	1,15
					Mandor Kayu	1,15
2	Penutup Plafond PVC t = 8 mm	M2	37,467	5	Pekerja	1,12
					Tukang Kayu	1,87
					Kepala Tukang Kayu	0,19
					Mandor Kayu	0,56
3	Rangka hollow galvanis 40x40x3 mm	M2	1187,0102	25	Pekerja	16,62
					Tukang Besi	16,62
					Kepala Tukang Besi	1,66
					Mandor Besi	0,85
4	List Plafond Gypsum 8 cm	M'	262,7	5	Pekerja	3,15
					Tukang Kayu	3,15
					Kepala Tukang Kayu	0,32
					Mandor Kayu	0,16
5	List Plafond PVC 8 cm	M'	34	5	Pekerja	0,68
					Tukang Kayu	0,34
					Kepala Tukang Kayu	0,03
					Mandor Kayu	0,03
IV	PEKERJAAN KERAMIK LANTAI & DINDING					
A	LANTAI SATU					
1	Pasang Keramik Lantai 60 x 60 (Polished)	M2	877,1352	45	Pekerja	13,64
					Tukang Batu	6,82
					Kepala Tukang Batu	0,68
					Mandor Batu	0,68
2	Pasang Keramik Lantai 60 x 60 (Unpolished)	M2	322,5580357	45	Pekerja	5,02
					Tukang Batu	2,51
					Kepala Tukang Batu	0,25
					Mandor Batu	0,25
3	Pasang Keramik Lantai 30 x 30 km/wc	M2	74,934	45	Pekerja	1,17
					Tukang Batu	0,58

					Kepala Tukang Batu	0,06
					Mandor Batu	0,06
4	Pasang Keramik dinding 30 x 60 km/wc	M2	136,08	8	Pekerja	15,31
					Tukang Batu	7,65
					Kepala Tukang Batu	0,77
					Mandor Batu	0,77
5	Pasang Plint Keramik 10 x 60 cm	M'	311,2	8	Pekerja	3,50
					Tukang Batu	3,50
					Kepala Tukang Batu	0,35
					Mandor Batu	0,19
6	Pasang Stepnosing Tangga 10 x 60 cm	M'	93	8	Pekerja	1,05
					Tukang Batu	1,05
					Kepala Tukang Batu	0,10
					Mandor Batu	0,06
B	LANTAI DUA					
1	Pasang Keramik Lantai 60 x 60 (Polished)	M2	923,5196	27	Pekerja	23,94
					Tukang Batu	11,97
					Kepala Tukang Batu	1,20
					Mandor Batu	1,20
2	Pasang Keramik Lantai 60 x 60 (Unpolished)	M2	295,1586	27	Pekerja	7,65
					Tukang Batu	3,83
					Kepala Tukang Batu	0,38
					Mandor Batu	0,38
3	Pasang Keramik Lantai 30 x 30 km/wc	M2	37,467	27	Pekerja	0,97
					Tukang Batu	0,49
					Kepala Tukang Batu	0,05
					Mandor Batu	0,05
4	Pasang Keramik dinding 30 x 60 km/wc	M2	68,04	3	Pekerja	20,41
					Tukang Batu	10,21
					Kepala Tukang Batu	1,02
					Mandor Batu	1,02
5	Pasang Plint Keramik 10 x 60 cm	M'	249,1	3	Pekerja	7,47
					Tukang Batu	7,47
					Kepala Tukang Batu	0,75
					Mandor Batu	0,42
V	PEKERJAAN SANITAIR					
A	LANTAI SATU					

1	Pasang Closet Duduk	Buah	14	7	Pekerja	6,60
					Tukang Batu	2,20
					Kepala Tukang Batu	0,02
					Mandor Batu	0,32
2	Pasang Urinoir	Buah	6	1	Pekerja	6,00
					Tukang Batu	6,00
					Kepala Tukang Batu	0,60
					Mandor Batu	0,30
3	Pasang Partisi Urinoir	Buah	4	1	Pekerja	4,00
					Tukang Batu	4,00
					Kepala Tukang Batu	0,40
					Mandor Batu	0,40
4	Pasang Cermin - Toilet	M2	9,6	1	Pekerja	0,14
					Tukang Kayu	1,44
					Kepala Tukang Kayu	0,14
					Mandor Kayu	0,08
5	Pasang Wastafel - Toilet	Buah	12	2	Pekerja	7,20
					Tukang Batu	8,70
					Kepala Tukang Batu	0,90
					Mandor Batu	0,60
6	Pasang Jet Washer - Toilet	Buah	14	1	Pekerja	0,14
					Tukang Batu	1,40
					Kepala Tukang Batu	0,14
					Mandor Batu	0,11
7	Pasang Floor Drain Stainless - Toilet	Buah	14	1	Pekerja	0,14
					Tukang Kayu	1,40
					Kepala Tukang Kayu	0,14
					Mandor Kayu	0,07
8	Pasang Partisi Toilet	M2	68,292	3	Pekerja	5,69
					Tukang Besi	5,69
					Kepala Tukang Besi	0,57
					Mandor Besi	0,30
B	LANTAI DUA					
1	Pasang Closet Duduk	Buah	7	2	Pekerja	11,55
					Tukang Batu	3,85
					Kepala Tukang Batu	0,04
					Mandor Batu	1,12
2	Pasang Urinoir	Buah	3	2	Pekerja	1,50
					Tukang Batu	1,50

					Kepala Tukang Batu	0,15
					Mandor Batu	0,08
3	Pasang Partisi Urinoir	Buah	2	2	Pekerja	1,00
					Tukang Batu	1,00
					Kepala Tukang Batu	0,10
					Mandor Batu	0,10
4	Pasang Cermin - Toilet	M2	4,8	1	Pekerja	0,07
					Tukang Kayu	0,72
					Kepala Tukang Kayu	0,07
					Mandor Kayu	0,04
5	Pasang Wastafel - Toilet	Buah	6	1	Pekerja	7,20
					Tukang Batu	8,70
					Kepala Tukang Batu	0,90
					Mandor Batu	0,60
6	Pasang Jet Washer - Toilet	Buah	7	1	Pekerja	0,07
					Tukang Batu	0,70
					Kepala Tukang Batu	0,07
					Mandor Batu	0,06
7	Pasang Floor Drain Stainless - Toilet	Buah	7	1	Pekerja	0,07
					Tukang Kayu	0,70
					Kepala Tukang Kayu	0,07
					Mandor Kayu	0,04
8	Pasang Partisi Toilet	M2	34,146	1	Pekerja	8,54
					Tukang Besi	8,54
					Kepala Tukang Besi	0,85
					Mandor Besi	0,44
VI	PEKERJAAN PENGECATAN					
A	LANTAI SATU					
1	Cat dinding bag. Luar termasuk kolom/balok, Drop Area (exterior) Tipe Wheatershield	M2	717,6561429	6	Pekerja	2,39
					Tukang Cat	7,54
					Kepala Tukang Cat	0,75
					Mandor Cat	0,36
2	Cat dinding bag. Dalam termasuk kolom/balok (interior) Tipe Acrilic emultion paint	M2	1174,174	6	Pekerja	3,91
					Tukang Cat	12,33
					Kepala Tukang Cat	1,23
					Mandor Cat	0,59
3	Cat Plafond Gypsum Tipe Acrilic emultion paint	M2	1139,825236	4	Pekerja	5,70

					Tukang Cat	17,95
					Kepala Tukang Cat	1,80
					Mandor Cat	0,85
4	Cat Railing Tangga, Dulux V-Gloss	M2	13,9152	1	Pekerja	0,28
					Tukang Cat	0,83
					Kepala Tukang Cat	0,06
					Mandor Cat	0,04
B	LANTAI DUA					
1	Cat dinding bag. Luar termasuk kolom/balok, Drop Area (exterior) Tipe Wheatershield	M2	517,15	5	Pekerja	2,07
					Tukang Cat	6,52
					Kepala Tukang Cat	0,65
					Mandor Cat	0,31
2	Cat dinding bag. Dalam termasuk kolom/balok (interior) Tipe Acrylic emulsion paint	M2	921,53	5	Pekerja	3,69
					Tukang Cat	11,61
					Kepala Tukang Cat	1,16
					Mandor Cat	0,55
3	Cat Plafond Gypsum Tipe Acrylic emulsion paint	M2	1112,0762	4	Pekerja	5,56
					Tukang Cat	17,52
					Kepala Tukang Cat	1,75
					Mandor Cat	0,83
4	Cat Railing Selasar + Balkon, Dulux V-Gloss	M2	148,1136	1	Pekerja	2,96
					Tukang Cat	8,89
					Kepala Tukang Cat	0,59
					Mandor Cat	0,44
V	PEKERJAAN ELEKTRIKAL DAN PEMIPAAN					
I	PEMIPAAN AIR BERSIH					
A	LANTAI 1					
1	Pipa PVC Kelas AW dia. 1"	M'	5,6	2	Pekerja	0,10
					Tukang Batu	0,17
					Kepala Tukang Batu	0,02
					Mandor Batu	0,01
2	Pipa PVC Kelas AW dia. 3/4"	M'	136,41	2	Pekerja	2,46
					Tukang Batu	4,09
					Kepala Tukang Batu	0,41
					Mandor Batu	0,14
B	LANTAI 2					

2	Pipa PVC Kelas AW dia. 3/4"	M'	93,51	2	Pekerja	1,68
					Tukang Batu	2,81
					Kepala Tukang Batu	0,28
					Mandor Batu	0,09
II	PEMIPAAN AIR KOTOR					
A	LANTAI 1					
1	Pipa PVC Kelas AW (Incl. Fitting & Accessories) dia. 4"	M'	64,92	2	Pekerja	2,63
					Tukang Batu	4,38
					Kepala Tukang Batu	0,44
					Mandor Batu	0,13
A	LANTAI 2					
1	Pipa PVC Kelas AW (Incl. Fitting & Accessories) dia. 4"	M'	15	2	Pekerja	0,61
					Tukang Batu	1,01
					Kepala Tukang Batu	0,10
					Mandor Batu	0,03
III	PEMIPAAN AIR BEKAS					
A	LANTAI 1					
1	Pipa PVC Kelas AW (Incl. Fitting & Accessories) dia. 3"	M'	95,84	2	Pekerja	3,88
					Tukang Batu	6,47
					Kepala Tukang Batu	0,65
					Mandor Batu	0,19
A	LANTAI 2					
1	Pipa PVC Kelas AW (Incl. Fitting & Accessories) dia. 3"	M'	31,38	2	Pekerja	1,27
					Tukang Batu	2,12
					Kepala Tukang Batu	0,21
					Mandor Batu	0,06
IV	PEMIPAAN AIR HUJAN					
A	LANTAI 1					
1	Pipa PVC Kelas AW (Incl. Fitting & Accessories) dia. 4"	M'	22,96	2	Pekerja	0,93
					Tukang Batu	1,55
					Kepala Tukang Batu	0,15
					Mandor Batu	0,05
A	LANTAI 2					
1	Roof Drain	Buah	2	1	Pekerja	0,02
					Tukang Kayu	0,20
					Kepala Tukang Kayu	0,02

					Mandor Kayu	0,01
V	INSTALASI KABEL FEEDER					
A	LANTAI 1					
1	NYM 3 x 4 mm2	M'	41,8	8	Pekerja	0,10
					Tukang Listrik	0,73
					Kepala tukang Listrik	0,05
					Mandor Listrik	0,05
B	LANTAI 2					
1	NYM 3 x 4 mm2	M'	48,71	7	Pekerja	0,14
					Tukang Listrik	0,97
					Kepala tukang Listrik	0,07
					Mandor Listrik	0,07
VI	INSTALASI KABEL TRAY					
A	LANTAI 1					
1	Pemasangan 1 m' Electronic Cable Tray size 150x50x3000x1 (2 mm)	M'	41,8	8	Pekerja	0,26
					Tukang Listrik	0,26
					Mandor Listrik	0,26
B	LANTAI 2					
1	Pemasangan 1 m' Electronic Cable Tray size 150x50x3000x1 (2 mm)	M'	48,71	7	Pekerja	0,35
					Tukang Listrik	0,35
					Mandor Listrik	0,35
VII	INSTALASI ARMATUR LAMPU, SAKLAR & STOP KONTAK					
A	LANTAI 1					
1	Lampu TL LED 2 x 14 Watt	Buah	35	1	Pekerja	1,40
					Tukang Listrik	4,90
					Kepala tukang Listrik	0,35
					Mandor Listrik	0,35
2	Lampu TL LED 14 Watt	Buah	4	1	Pekerja	0,16
					Tukang Listrik	0,56
					Kepala tukang Listrik	0,04
					Mandor Listrik	0,04
3	Lampu Bohlam LED 10 Watt	Buah	14	1	Pekerja	0,28
					Tukang Listrik	1,40

					Kepala tukang Listrik	0,14
					Mandor Listrik	0,14
4	Saklar Tunggal 10A	Buah	10	1	Pekerja	0,40
					Tukang Listrik	1,40
					Kepala tukang Listrik	0,10
					Mandor Listrik	0,10
5	Saklar Seri 10A	Buah	8	1	Pekerja	0,32
					Tukang Listrik	1,12
					Kepala tukang Listrik	0,08
					Mandor Listrik	0,08
6	Stop Kontak 250 watt	Buah	23	1	Pekerja	0,92
					Tukang Listrik	3,22
					Kepala tukang Listrik	0,23
					Mandor Listrik	0,23
A	LANTAI 2					
1	Lampu TL LED 2 x 14 Watt	Buah	36	1	Pekerja	1,44
					Tukang Listrik	5,04
					Kepala tukang Listrik	0,36
					Mandor Listrik	0,36
2	Lampu TL LED 14 Watt	Buah	4	1	Pekerja	0,16
					Tukang Listrik	0,56
					Kepala tukang Listrik	0,04
					Mandor Listrik	0,04
3	Lampu Bohlam LED 10 Watt	Buah	14	1	Pekerja	0,28
					Tukang Listrik	1,40
					Kepala tukang Listrik	0,14
					Mandor Listrik	0,14
4	Saklar Tunggal 10A	Buah	5	1	Pekerja	0,20
					Tukang Listrik	0,70
					Kepala tukang Listrik	0,05
					Mandor Listrik	0,05
5	Saklar Seri 10A	Buah	8	1	Pekerja	0,32
					Tukang Listrik	1,12
					Kepala tukang Listrik	0,08
					Mandor Listrik	0,08
6	Stop Kontak 250 watt	Buah	17	1	Pekerja	0,68
					Tukang Listrik	2,38
					Kepala tukang Listrik	0,17

					Mandor Listrik	0,17
VII	INSTALASI PENERANGAN & STOP KONTAK					
A	LANTAI 1					
1	NYA 3 x 2,5 mm ² + PVC Conduit dia.20 untuk Lampu	M'	532,47	8	Pekerja	1,33
					Tukang Listrik	9,32
					Kepala tukang Listrik	0,67
					Mandor Listrik	0,67
2	NYA 3 x 2,5 mm ² + PVC Conduit dia.20 untuk Stop Kontak	M'	211,22	8	Pekerja	0,53
					Tukang Listrik	3,70
					Kepala tukang Listrik	0,26
					Mandor Listrik	0,26
A	LANTAI 2					
1	NYA 3 x 2,5 mm ² + PVC Conduit dia.20 untuk Lampu	M'	537,987	7	Pekerja	1,54
					Tukang Listrik	10,76
					Kepala tukang Listrik	0,77
					Mandor Listrik	0,77
2	NYA 3 x 2,5 mm ² + PVC Conduit dia.20 untuk Stop Kontak	M'	163,28	7	Pekerja	0,47
					Tukang Listrik	3,27
					Kepala tukang Listrik	0,23
					Mandor Listrik	0,23
VII	INSTALASI KABEL CCTV					
A	LANTAI 1					
1	Kabel Croaxial Tipe RG59	M'	100,056	8	Pekerja	0,25
					Tukang Listrik	1,75
					Kepala tukang Listrik	0,13
					Mandor Listrik	0,13
B	LANTAI 2					
1	Kabel Croaxial Tipe RG59	M'	98,7	7	Pekerja	0,28
					Tukang Listrik	1,97
					Kepala tukang Listrik	0,14
					Mandor Listrik	0,14
VII	INSTALASI KABELWIFI					
A	LANTAI 1					
1	Kabel LAN untuk Wifi	M'	49,94	8	Pekerja	0,12

Lampiran B.6. Rekap Kebutuhan Bahan

No.	URAIAN PEKERJAAN	SATUAN	VOLUME	SUMBER DAYA	KOEFISIEN	RESOURCE	SATUAN
I PEKERJAAN PERSIAPAN							
1	Direksi Keet	m2	120,00	Kaso 5/7 cm	0,03	3,60	m3
				Triplek 4 mm	0,20	24,00	lembar
				Seng	1,24	148,80	lembar
				Paku 3"	0,75	90,00	kg
2	Pekerjaan pagar keliling	m'	256,00	Kayu Dolken diameter 8-10 cm	1,25	320,00	Batang
				Semen Portland	5,00	1280,00	Kg
				Pasir Pasang	0,01	1,28	m3
				Kerikil 1m3	0,01	2,30	m3
				Kaso 5/7 cm	0,07	18,43	m3
				Paku 5 cm dan 7 cm	0,06	15,36	Kg
				Residu	0,40	102,40	Liter
3	Pekerjaan Bowplank	m'	168,00	Kaso 5/7 cm	0,01	2,02	m3
				Paku 3"	0,02	3,36	Kg
				Papan Kayu 3/20	0,01	1,18	M3
4	Pekerjaan Pemasangan Papan Kerja	Ls	1,00	Papan Kerja	4025000,00	4025000,00	Ls
II PEKERJAAN GALIAN							
1	Pekerjaan Urugan Pasir tebal 10 cm (Pilecap):	M3	16,51	Pasir Urug	1,20	19,81	M3
2	Pekerjaan Lantai Kerja tebal 5 cm (Pilecap):	M3	8,25	Semen Portland	247,00	2038,86	kg
				Pasir Beton	869,00	7173,14	kg
				Kerikil (Maks 30 mm)	1000,00	8254,48	kg
				Air	215,00	1774,71	ltr
3	Pekerjaan Urugan Pasir tebal 10 cm (Sloof):	M3	43,27	Pasir Urug	1,20	51,92	M3
4	Pekerjaan Lantai Kerja tebal 5 cm (Sloof):	M3	21,63	Semen Portland	247,00	5343,71	kg
				Pasir Beton	869,00	18800,35	kg
				Kerikil (Maks 30 mm)	1000,00	21634,46	kg
				Air	215,00	4651,41	ltr
III PEKERJAAN STRUKTUR BAWAH							
A. PEKERJAAN PONDASI							
1	Mobilisasi Alat Pancang	Ls	3,00	Mobilisasi Alat Pancang	1,00	3,00	Ls
2	Pekerjaan pemancangan	buah	60,00	Sepatu Pancang beton 60 cm	1,00	60,00	
				Tiang pancang dia.60 cm	12,00	720,00	

B	PEKERJAAN PILECAP						
1	Pekerjaan Beton	M3	81,33	Ready Mix K-300	1,02	82,96	M3
2	Pekerjaan Pembesian	100 Kg	94,99	Besi Beton	105,00	9973,47	kg
				Kawat Beton	2,80	265,96	kg
3	Pekerjaan Bekisting	M2	178,88	Multiplek 18 mm	0,13	22,90	Lembar
				Kaso 5/7 cm	0,01	1,61	m3
				Paku 5 cm dan 7 cm	0,25	44,72	kg
				Minyak Bekisting	0,20	35,78	Liter
C	SLOOF						
1	Pekerjaan Beton	M3	30,44	Ready Mix K-300	1,02	31,05	M3
2	Pekerjaan Pembesian	100 Kg	50,67	Besi Beton	105,00	5320,71	kg
				Kawat Beton	2,80	141,89	kg
3	Pekerjaan Bekisting	M2	317,45	Multiplek 18 mm	0,13	40,63	Lembar
				Kaso 5/7 cm	0,01	2,86	m3
				Paku 5 cm dan 7 cm	0,25	79,36	kg
				Minyak Bekisting	0,20	63,49	Liter
D	KOLOM PEDESTAL						
1	Pekerjaan Beton	M3	14,42	Ready Mix K-300	1,02	14,71	M3
2	Pekerjaan Pembesian	100 Kg	61,16	Besi Beton	105,00	6421,53	kg
				Kawat Beton	2,80	171,24	kg
3	Pekerjaan Bekisting	M2	73,51	Papan Kayu 3/20	0,01	1,03	Lembar
				Kaso 5/7 cm	0,01	0,44	m3
				Paku 5 cm dan 7 cm	0,30	22,05	kg
				Minyak Bekisting	0,20	14,70	Liter
III	PEKERJAAN STRUKTUR ATAS						
A.	PEKERJAAN LANTAI DASAR						
A.1	PEKERJAAN KOLOM PEKERJAAN BETON						
1	Pekerjaan Beton	M3	41,70	Ready Mix K-300	1,02	42,54	M3
2	Pekerjaan Pembesian	100 Kg	122,19	Besi Beton	105,00	12830,44	kg
				Kawat Beton	2,80	342,14	kg
3	Pekerjaan Bekisting	M2	220,54	Papan Kayu 3/20	0,01	3,09	Lembar
				Kaso 5/7 cm	0,01	1,32	m3

				Paku 5 cm dan 7 cm	0,30	66,16	kg
				Minyak Bekisting	0,20	44,11	Liter
A.2	PEKERJAAN PELAT						
1	pekerjaan urugan pasir 10 cm	M3	152,64	Pasir Urug	1,20	183,17	M3
2	Pekerjaan Cor Lantai 5 cm	M3	152,64	Ready Mix K-175	1,02	155,69	kg
A.3	PEKERJAAN TANGGA, BALOK, DAN KOLOM BORDES PEKERJAAN BETON						
1	Pekerjaan Beton	M3	13,51	Ready Mix K-300	1,02	13,78	M3
2	Pekerjaan Pembesian	100 Kg	9,50	Besi Beton	105,00	997,73	kg
				Kawat Beton	2,80	26,61	kg
3	PEKERJAAN BEKISTING						
a	Kolom KB (Samping kanan & kiri))	M2	10,80	Papan Kayu 3/20	0,01	0,15	Lembar
				Kaso 5/7 cm	0,01	0,06	m3
				Paku 5 cm dan 7 cm	0,30	3,24	kg
				Minyak Bekisting	0,20	2,16	Liter
b	Balok Bordes 20x40 cm	M2	6,60	Papan Kayu 3/20	0,13	0,85	Lembar
				Kaso 5/7 cm	0,01	0,07	m3
				Paku 5 cm dan 7 cm	0,25	1,65	kg
				Minyak Bekisting	0,20	1,32	Liter
c	Tangga lt. 1 (Kiri dan Kanan)	M2	73,12	Papan Kayu 3/20	0,13	9,36	Lembar
				Kaso 5/7 cm	0,01	0,80	m3
				Paku 5 cm dan 7 cm	0,25	18,28	kg
				Minyak Bekisting	0,20	14,62	Liter
B.	PEKERJAAN LANTAI 2						
B.1	PEKERJAAN KOLOM						
1	Pekerjaan Beton	M3	30,66	Ready Mix K-300	1,02	31,27	M3
2	Pekerjaan Pembesian	100 Kg	90,15	Besi Beton	105,00	9466,21	kg
				Kawat Beton	2,80	252,43	kg
3	Pekerjaan Bekisting	M2	169,65	Papan Kayu 3/20	0,01	2,38	Lembar
				Kaso 5/7 cm	0,01	1,02	m3
				Paku 5 cm dan 7 cm	0,30	50,89	kg
				Minyak Bekisting	0,20	33,93	Liter

B.2	PEKERJAAN BALOK						
	PEKERJAAN BETON						
1	Pekerjaan Beton	M3	151,19	Ready Mix K-300	1,02	154,21	M3
2	Pekerjaan Pembesian	100 Kg	344,02	Besi Beton	105,00	36122,21	kg
				Kawat Beton	2,80	963,26	kg
	PEKERJAAN BEKISTING						
3	Pekerjaan Bekisting	M2	1158,63	Multiplek 18 mm	0,13	148,30	Lembar
				Kaso 5/7 cm	0,01	12,74	m3
				Paku 5 cm dan 7 cm	0,25	289,66	kg
				Minyak Bekisting	0,20	231,73	Liter
B.3	PEKERJAAN PELAT LANTAI 2						
1	Pekerjaan Beton	M3	125,42	Ready Mix K-300	1,02	127,93	M3
2	Plat lantai 2 t =130 mm	100 Kg	97,35	Besi Beton	105,00	10221,35	M3
				Kawat Beton	1,50	146,02	M3
3	Pekerjaan Bekisting	M2	1068,90	Multiplek 18 mm	0,13	136,82	Lembar
				Kaso 5/7 cm	0,03	26,72	m3
				Paku 5 cm dan 7 cm	0,47	502,38	kg
				Minyak Bekisting	0,20	213,78	Liter
C	PEKERJAAN ATAP						
C1	PEKERJAAN RING BALOK						
1	Pekerjaan Beton	M3	21,02	Ready Mix K-300	1,02	21,44	M3
2	Pekerjaan Pembesian	100 Kg	27,28	Besi Beton	105,00	2864,32	kg
				Kawat Beton	2,80	76,38	kg
3	Pekerjaan Bekisting	M2	181,30	Multiplek 18 mm	0,13	23,21	Lembar
				Kaso 5/7 cm	0,01	1,99	m3
				Paku 5 cm dan 7 cm	0,25	45,33	kg
				Minyak Bekisting	0,20	36,26	Liter
C2	PEKERJAAN ATAP						
1	Perakitan Kuda-Kuda (2L50)	Kg	4972,89	Baja Profil L.50.50.5	1,15	5718,83	kg
				baut 12 mm	0,36	1782,78	buah
2	Perakitan Kuda-Kuda (2L60)	Kg	3636,79	Baja Profil L.60.60.6	1,15	4182,31	Kg
				baut 12 mm	0,33	1188,87	buah
3	Instalasi Ikatan Angin	Kg	378,72	Besi Beton	1,15	435,53	Kg

4	Instalasi Gording	Kg	5500,80	Profil C150x65x20x3.2	1,15	6325,92	Kg
				baut 12 mm	0,21	1155,17	buah
5	Instalasi Sagrod	Kg	246,80	Besi Beton	1,15	283,82	Kg
6	Instalasi Usuk	Kg	1702,00	Profil C60x30x2.3	1,15	1957,30	Kg
7	Instalasi Reng	Kg	1647,00	Reng G550	1,15	1894,05	Kg
8	Pemasangan Atap sirap	m2	1489,75	Sirap Kayu	30,00	44692,50	buah
				Paku biasa 1/2"-1"	0,20	297,95	kg
IV	PEKERJAAN ARSITEKTUR						
I	PEKERJAAN PASANGAN DINDING & BETON PRAKTIS						
A	LANTAI SATU						
1	Pasangan Dinding Bata ringan t = 10 cm	M2	814,182	Bata Ringan 10 cm	8,40	6839,13	Buah
				Mortar Siap Pakai	0,06	51,29	Kg
2	Pasangan Dinding Bata merah t = 11 cm	M2	303,42	Bata merah	140,00	42478,80	Buah
				Semen Portland	22,20	6735,92	Kg
				Pasir Pasang	0,10	30,95	m3
3	Plesteran Trasram	M2	606,84	Semen Portland	20,67	12544,60	Kg
				Pasir pasang	0,02	12,99	M3
4	Plesteran Mortar	M2	1188,876	Semen Portland	12,96	15407,83	Kg
				Pasir pasang	0,04	45,77	M3
5	Acian	M2	1795,716	Semen Portland	3,25	5836,08	Kg
6	Kolom Praktis 11 x 11 cm	M'	400,5	Kayu Kelas 3	0,00	0,80	M3
				Paku 5cm - 12 cm	0,01	4,01	Kg
				Besi beton	3,00	1201,50	Kg
				Kawat Beton	0,45	180,23	Kg
				Semen Portland	3,25	1301,63	Kg
				Pasir Pasang	0,01	2,40	M3
				Kerikil	0,01	3,60	M3
7	Balok Latei	M'	77,84	Kayu Kelas 3	0,00	0,16	M3
				Paku 5cm - 12 cm	0,01	0,78	Kg
				Besi beton	3,00	233,52	Kg
				Kawat Beton	0,45	35,03	Kg
				Semen Portland	3,25	252,98	Kg
				Pasir Pasang	0,01	0,47	M3
				Kerikil	0,01	0,70	M3
8	Sponengan	M'	409,2336	Semen Portland	0,50	204,62	Kg

				Pasir Pasang	0,01	5,32	m3
B	LANTAI DUA						
1	Pasangan Dinding Bata Ringan t = 10 cm	M2	773,755	Bata Ringan 10 cm	8,40	6499,54	Buah
				Mortar Siap Pakai	0,06	48,75	Kg
2	Pasangan Dinding Bata merah t = 11 cm	M2	151,71	Bata merah	140,00	21239,40	Buah
				Semen Portland	22,20	3367,96	Kg
				Pasir Pasang	0,10	2,00	m3
3	Plesteran Trasram	M2	303,42	Semen Portland	20,67	6272,30	Kg
				Pasir pasang	0,02	6,49	M3
4	Plesteran Mortar	M2	1387,23	Semen Portland	12,96	17978,50	Kg
				Pasir pasang	0,04	53,41	M3
5	Acian	M2	1690,65	Semen Portland	3,25	5494,61	Kg
6	Kolom Praktis 11 x 11 cm	M'	360	Kayu Kelas 3	0,00	0,72	M3
				Paku 5cm - 12 cm	0,01	3,60	Kg
				Besi beton	3,00	1080,00	Kg
				Kawat Beton	0,45	162,00	Kg
				Semen Portland	3,25	1170,00	Kg
				Pasir Pasang	0,01	2,16	M3
				Kerikil	0,01	3,24	M3
7	Balok Latei	M'	73,61	Kayu Kelas 3	0,00	0,15	M3
				Paku 5cm - 12 cm	0,01	0,74	Kg
				Besi beton	3,00	220,83	Kg
				Kawat Beton	0,45	33,12	Kg
				Semen Portland	3,25	239,23	Kg
				Pasir Pasang	0,01	0,44	M3
				Kerikil	0,01	0,66	M3
8	Sponengan	M'	378,3368	Semen Portland	0,50	189,17	Kg
				Pasir Pasang	0,01	4,92	m3
II	PEKERJAAN KUSEN PINTU / JENDELA , ASSESORIES & RAILING						
A	LANTAI SATU						
1	Pembuatan dan Pemasangan Kusen Pintu ; Kusen Jendela	M3	1,872	Kayu Untuk Kusen Kelas 1	1,10	2,06	M3
				Paku 10 cm	1,25	2,34	kg
				Lem Kayu	1,00	1,87	kg
2	Pemasangan Pintu Tipe 1 + Assesories	Unit	3	Daun Pintu Tipe 1 (Kayu Kamper Samarinda)	1,00	3,00	Unit
				Engsel Stainless Stell 5"	6,00	18,00	buah

				Handle Tipe 1	2,00	6,00	buah
3	Pemasangan Pintu Tipe 2 + Assesories	Unit	3	Daun Pintu Tipe 2 (Kayu Kamper Samarinda)	1,00	3,00	Unit
				Engsel Stainless Stell 5"	6,00	18,00	buah
				Handle Tipe 1	2,00	6,00	buah
4	Pemasangan Pintu Tipe 4 + Assesories	Unit	3	Daun Pintu Tipe 4 (Kayu Kamper Samarinda)	1,00	3,00	Unit
				Engsel Stainless Stell 4"	3,00	9,00	buah
				Handle Tipe 2	1,00	3,00	buah
5	Pemasangan Pintu Tipe 5 + Assesories	Unit	4	Daun Pintu Tipe 5 (Kayu Kamper Samarinda)	1,00	4,00	Unit
				Engsel Stainless Stell 4"	3,00	12,00	buah
				Handle Tipe 2	1,00	4,00	buah
6	Pemasangan Jendela Tipe 1 + Assesories	Unit	6	Daun Jendela Tipe 1 (Kayu Kamper Samarinda)	1,00	6,00	Unit
				Kaca Bening 5 mm	1,10	6,60	M2
				Sealant	0,05	0,30	kg
7	Pemasangan Jendela Tipe 2 + Assesories	Unit	12	Daun Jendela Tipe 2 (Kayu Kamper Samarinda)	1,00	12,00	Unit
				Kaca Bening 5 mm	1,10	13,20	M2
				Sealant	0,05	0,60	kg
8	Pemasangan Jendela Tipe 3 + Assesories	Unit	2	Daun Jendela Tipe 3 (Kayu Kamper Samarinda)	1,00	2,00	Unit
				Kaca Bening 5 mm	1,10	2,20	M2
				Sealant	0,05	0,10	kg
9	Pemasangan Boven + Assesories	Unit	8	Daun Boven (Kayu Kamper Samarinda)	1,00	8,00	Unit
				Kaca Bening 5 mm	1,10	8,80	M2
				Sealant	0,05	0,40	kg
				Casement 8"	1,00	8,00	Pasang
10	Finishing Melamin Kusen Daun Pintu ; Kusen Daun Jendela	M2	145,11068	Wood Filler	0,15	21,77	kg
				Woodstain	0,25	36,28	Liter
				Sending Sealer	0,25	36,28	Liter
				Melamin Top Coat	0,25	36,28	Liter
				Thinner	0,50	72,56	Liter
				Amplas	0,50	72,56	Lembar
				Alat Bantu (Alat semprot dll)	1,00	145,11	Ls
11	Fabrikasi dan Pemasangan Railing Tangga	M'	173,94	Besi Hollow 40x40x1.2 mm	1,05	182,64	M'
				Kawat Las	0,01	1,04	kg
				Solar	0,01	0,87	liter

				Minyak Pelumas	0,00	0,17	liter
B	LANTAI DUA						
1	Pembuatan dan Pemasangan Kusen Pintu ; Kusen Jendela	M3	1,85238	Kayu Untuk Kusen Kelas 1	1,10	2,04	M3
				Paku 10 cm	1,25	2,32	kg
				Lem Kayu	1,00	1,85	kg
2	Pemasangan Pintu Tipe 1 + Assesories	Unit	2	Daun Pintu Tipe 1 (Kayu Kamper Samarinda)	1,00	2,00	Unit
				Engsel Stainless Stell 5"	6,00	12,00	buah
				Handle Tipe 1	2,00	4,00	buah
3	Pemasangan Pintu Tipe 3 + Assesories	Unit	1	Daun Pintu Tipe 3 (Kayu Kamper Samarinda)	1,00	1,00	Unit
				Engsel Stainless Stell 5"	3,00	3,00	buah
				Handle Tipe 2	1,00	1,00	buah
4	Pemasangan Pintu Tipe 5 + Assesories	Unit	2	Daun Pintu Tipe 5 (Kayu Kamper Samarinda)	1,00	2,00	Unit
				Engsel Stainless Stell 4"	3,00	6,00	buah
				Handle Tipe 2	1,00	2,00	buah
5	Pemasangan Jendela Tipe 1 + Assesories	Unit	20	Daun Jendela Tipe 1 (Kayu Kamper Samarinda)	1,00	20,00	Unit
				Kaca Bening 5 mm	1,10	22,00	M2
				Sealent	0,05	1,00	kg
6	Pemasangan Jendela Tipe 2 + Assesories	Unit	2	Daun Jendela Tipe 2 (Kayu Kamper Samarinda)	1,00	2,00	Unit
				Kaca Bening 5 mm	1,10	2,20	M2
				Sealent	0,05	0,10	kg
7	Pemasangan Jendela Tipe 3 + Assesories	Unit	2	Daun Jendela Tipe 3 (Kayu Kamper Samarinda)	1,00	2,00	Unit
				Kaca Bening 5 mm	1,10	2,20	M2
				Sealent	0,05	0,10	kg
8	Pemasangan Boven + Assesories	Unit	4	Daun Boven (Kayu Kamper Samarinda)	1,00	4,00	Unit
				Kaca Bening 5 mm	1,10	4,40	M2
				Sealent	0,05	0,20	kg
				Casement 8"	1,00	4,00	Pasang
9	Finishing Melamin Kusen Daun Pintu ; Kusen Daun Jendela	M2	92,23784	Wood Filler	0,15	13,84	kg
				Woodstain	0,25	23,06	Liter
				Sending Sealer	0,25	23,06	Liter
				Melamin Top Coat	0,25	23,06	Liter
				Thinner	0,50	46,12	Liter

				Amplas	0,50	46,12	Lembar
				Alat Bantu (Alat semprot dll)	1,00	92,24	Ls
10	Fabrikasi dan Pemasangan Railing Selasar + Balkon, Hollow 40 x 40 x 1,2 mm	M'	925,71	Besi Hollow 40x40x1.2 mm	1,05	972,00	M'
				Kawat Las	0,01	5,55	kg
				Solar	0,01	4,63	liter
				Minyak Pelumas	0,00	0,93	liter
III	PEKERJAAN PLAFOND						
A	LANTAI SATU						
1	Penutup plafond Gypsum t =9 mm	M2	1214,759236	gypsum board (12x240x9)	0,36	442,17	Lembar
				Paku Sekrup	0,11	133,62	Kg
2	Penutup Plafond PVC t = 8 mm	M2	74,934	Plavon PVC Indahfon t = 8 mm	1,05	78,68	M2
				Screw	18,00	1348,81	Buah
3	Rangka hollow galvanis 40x40x3 mm	M2	1289,693236	Rangka hollow 40.40.3	4,00	5158,77	M
				Assesoris (perkuatan & las dll)	1,00	1289,69	0
4	List Plafond Gypsum 8 cm	M'	330,4	List Gypsum 8 cm	1,05	346,92	M
				Tepung Gypsum	0,15	49,56	Kg
5	List Plafond PVC 8 cm	M'	68	List PVC Shunda 3 cm	1,05	71,40	M
				Screw	6,00	408,00	Buah
B	LANTAI DUA						
1	Penutup plafond Gypsum t=9	M2	1149,5432	gypsum board (12x240x9)	0,36	418,43	Lembar
				Paku Sekrup	0,11	126,45	Kg
2	Penutup Plafond PVC t = 8 mm	M2	37,467	Plavon PVC Indahfon t = 8 mm	1,05	39,34	M2
				Screw	18,00	674,41	Buah
3	Rangka hollow galvanis 40x40x3 mm	M2	1187,0102	Rangka hollow 40.40.3	4,00	4748,04	M
				Assesoris (perkuatan & las dll)	1,00	1187,01	0
4	List Plafond Gypsum 8 cm	M'	262,7	List Gypsum 8 cm	1,05	275,84	M
				Tepung Gypsum	0,15	39,41	Kg
5	List Plafond PVC 8 cm	M'	34	List PVC Shunda 3 cm	1,05	35,70	M
				Screw	6,00	204,00	Buah
IV	PEKERJAAN KERAMIK LANTAI & DINDING						
A	LANTAI SATU						
1	Pasang Keramik Lantai 60 x 60 (Polished)	M2	877,1352	Keramik 60x60 Polished	3,10	2719,12	buah
				Semen Portland	9,60	8420,50	Kg
				Pasir pasang	0,05	39,47	M3

				Semen Warna	1,50	1315,70	Kg
2	Pasang Keramik Lantai 60 x 60 (Unpolished)	M2	322,5580357	Keramik 60x60 Unpolished	3,10	999,93	buah
				Semen Portland	9,60	3096,56	Kg
				Pasir pasang	0,05	14,52	M3
				Semen Warna	1,50	483,84	Kg
3	Pasang Keramik Lantai 30 x 30 km/wc	M2	74,934	Ubin Keramik 30x30	1,05	78,68	dus
				Semen Portland	10,00	749,34	Kg
				Pasir pasang	0,05	3,37	M3
				Semen Warna	0,50	37,47	Kg
4	Pasang Keramik dinding 30 x 60 km/wc	M2	136,08	Keramik Dinding 30x60	1,06	144,24	M2
				Semen Portland	9,60	1306,37	Kg
				Pasir pasang	0,02	2,45	M3
				Semen Warna	0,97	132,00	Kg
5	Pasang Plint Keramik 10 x 60 cm	M'	311,2	Plint 10 x 60	1,70	529,04	buah
				Semen Portland	1,14	354,77	Kg
				Pasir pasang	0,00	0,93	M3
				Semen Warna	0,10	31,12	Kg
6	Pasang Stepnosing Tangga 10 x 60 cm	M'	93	Stepnosing 10x60	2,00	186,00	Buah
				Semen Portland	1,14	106,02	Kg
				Pasir Pasang	0,00	0,28	m3
				Semen Warna	0,01	0,56	kg
B	LANTAI DUA						
1	Pasang Keramik Lantai 60 x 60 (Polished)	M2	923,5196	Keramik 60x60 Polished	3,10	2862,91	buah
				Semen Portland	9,60	8865,79	Kg
				Pasir pasang	0,05	41,56	M3
				Semen Warna	1,50	1385,28	Kg
2	Pasang Keramik Lantai 60 x 60 (Unpolished)	M2	295,1586	Keramik 60x60 Unpolished	3,10	914,99	buah
				Semen Portland	9,60	2833,52	Kg
				Pasir pasang	0,05	13,28	M3
				Semen Warna	1,50	442,74	Kg
3	Pasang Keramik Lantai 30 x 30 km/wc	M2	37,467	Ubin Keramik 30x30	1,05	39,34	dus
				Semen Portland	10,00	374,67	Kg
				Pasir pasang	0,05	1,69	M3
				Semen Warna	0,50	18,73	Kg
4	Pasang Keramik dinding 30 x 60 km/wc	M2	68,04	Keramik Dinding 30x60	1,06	72,12	M2
				Semen Portland	9,60	653,18	Kg
				Pasir pasang	0,02	1,22	M3
				Semen Warna	0,97	66,00	Kg

5	Pasang Plint Keramik 10 x 60 cm	M'	249,1	Plint 10 x 60	1,70	423,47	buah
				Semen Portland	1,14	283,97	Kg
				Pasir pasang	0,00	0,75	M3
				Semen Warna	0,10	24,91	Kg
V	PEKERJAAN SANITAIR						
A	LANTAI SATU						
1	Pasang Closet Duduk	Buah	14	Closet Duduk TOTO CW638J	1,05	14,70	unit
				Perlengkapan Closed(6%)	1,00	14,00	Ls
2	Pasang Urinoir	Buah	6	Urinoir Lengkap	1,00	6,00	Unit
				Semen Portland	6,00	36,00	Kg
				Pasir Pasang	0,01	0,06	M3
3	Pasang Partisi Urinoir	Buah	4	Partisi Urinoir TOTO A100	1,00	4,00	Buah
				Perlengkapan Partisi Urinoir (30%)	1,00	4,00	Ls
				Semen Portland	6,00	24,00	Kg
				Pasir Pasang	0,01	0,04	M3
4	Pasang Cermin - Toilet	M2	9,6	Kaca Cermin 5 mm ex Asahi	1,10	10,56	M2
				Sealent	0,05	0,48	kg
5	Pasang Wastafel - Toilet	Buah	12	Wastafel Vanitory Monaco exAmstad	1,00	12,00	Buah
				Perlengkapan(12% x Wastafel)	0,12	1,44	Ls
				Semen Portland	6,00	72,00	Kg
				Pasir Pasang	0,01	0,12	M3
6	Pasang Jet Washer - Toilet	Buah	14	Jet Washer American Standard FFTP404-WTFB0	1,00	14,00	Buah
				Seal Tape	1,00	14,00	Buah
7	Pasang Floor Drain Stainless - Toilet	Buah	14	Floor Drain Stainless	1,00	14,00	Buah
8	Pasang Partisi Toilet	M2	68,292	Rangka hollow 40.40.3	3,50	239,02	M2
				Perlengkapan Partisi Toilet (100%)	1,00	68,29	ls
				Sekat PVC 0.5 mm	1,00	68,29	M2
				Grendel Pintu PVC	1,00	68,29	Buah
B	LANTAI DUA						
1	Pasang Closet Duduk	Buah	7	Closet Duduk TOTO CW638J	1,05	7,35	unit
				Perlengkapan Closed(6%)	1,00	7,00	Ls
2	Pasang Urinoir	Buah	3	Urinoir Lengkap	1,00	3,00	Unit
				Semen Portland	6,00	18,00	Kg
				Pasir Pasang	0,01	0,03	M3
3	Pasang Partisi Urinoir	Buah	2	Partisi Urinoir TOTO A100	1,00	2,00	Buah
				Perlengkapan Partisi Urinoir (30%)	1,00	2,00	Ls

				Semen Portland	6,00	12,00	Kg
				Pasir Pasang	0,01	0,02	M3
4	Pasang Cermin - Toilet	M2	4,8	Kaca Cermin 5 mm ex Asahi	1,10	5,28	M2
				Sealent	0,05	0,24	kg
5	Pasang Wastafel - Toilet	Buah	6	Wastafel Vanitory Monaco exAmstad	1,00	6,00	Buah
				Perlengkapan(12% x Wastafel)	0,12	0,72	Ls
				Semen Portland	6,00	36,00	Kg
				Pasir Pasang	0,01	0,06	M3
6	Pasang Jet Washer - Toilet	Buah	7	Jet Washer American Standard FFTP404-WTFB0	1,00	7,00	Buah
				Seal Tape	1,00	7,00	Buah
7	Pasang Floor Drain Stainless - Toilet	Buah	7	Floor Drain Stainless	1,00	7,00	Buah
8	Pasang Partisi Toilet	M2	34,146	Rangka hollow 40.40.3	3,50	119,51	M2
				Perlengkapan Partisi Toilet (100%)	1,00	34,15	ls
				Sekat PVC 0.5 mm	1,00	34,15	M2
				Grendel Pintu PVC	1,00	34,15	Buah
VI	PEKERJAAN PENGECATAN						
A	LANTAI SATU						
1	Cat dinding bag. Luar termasuk kolom/balok, Drop Area (exterior) Tipe Wheatershield	M2	717,6561429	Plamuur	0,10	71,77	Kg
				Cat Dasar Exterior	0,10	71,77	Kg
				Cat Penutup Exterior	0,26	186,59	Kg
2	Cat dinding bag. Dalam termasuk kolom/balok (interior) Tipe Acrilic emulsion paint	M2	1174,174	Plamuur	0,10	117,42	Kg
				Cat Dasar Interior	0,10	117,42	Kg
				Cat Penutup Interior	0,26	305,29	Kg
3	Cat Plafond Gypsum Tipe Acrilic emulsion paint	M2	1139,825236	Plamuur	0,10	113,98	Kg
				Cat Dasar Interior	0,10	113,98	Kg
				Cat Penutup Interior	0,26	296,35	Kg
4	Cat Railing Tangga, Dulux V-Gloss	M2	13,9152	Cat Minyak Dulux V-Gloss	0,10	1,39	kg
B	LANTAI DUA						
1	Cat dinding bag. Luar termasuk kolom/balok, Drop Area (exterior) Tipe Wheatershield	M2	517,15	Plamuur	0,10	51,72	Kg
				Cat Dasar Exterior	0,10	51,72	Kg
				Cat Penutup Exterior	0,26	134,46	Kg
2	Cat dinding bag. Dalam termasuk kolom/balok (interior) Tipe Acrilic emulsion paint	M2	921,53	Plamuur	0,10	92,15	Kg

				Cat Dasar Interior	0,10	92,15	Kg
				Cat Penutup Interior	0,26	239,60	Kg
3	Cat Plafond Gypsum Tipe Acrilic emultion paint	M2	1112,0762	Plamuur	0,10	111,21	Kg
				Cat Dasar Interior	0,10	111,21	Kg
				Cat Penutup Interior	0,26	289,14	Kg
4	Cat Railing Selasar + Balkon, Dulux V-Gloss	M2	148,1136	Cat Minyak Dulux V-Gloss	0,10	14,81	kg
I	PEMIPAAN AIR BERSIH						
A	LANTAI 1						
1	Pipa PVC Kelas AW dia. 1"	M'	5,6	Pipa PVC Kelas dia 25 mm	1,20	6,72	M
				Perlengkapan Pipa PVC Kelas AW dia 25 (12.5%)	1,00	5,60	M
2	Pipa PVC Kelas AW dia. 3/4"	M'	136,41	Pipa PVC Kelas dia 20 mm	1,20	163,69	M
				Perlengkapan Pipa PVC Kelas AW dia 20 (12.5%)	1,00	136,41	
B	LANTAI 2						
1	Pipa PVC Kelas AW dia. 3/4"	M'	93,51	Pipa PVC Kelas dia 20 mm	1,20	112,21	M
				Perlengkapan Pipa PVC Kelas AW dia 20 (12.5%)	1,00	93,51	
II	PEMIPAAN AIR KOTOR						
A	LANTAI 1						
1	Pipa PVC Kelas AW (Incl. Fitting & Accessories) dia. 4"	M'	64,92	PVC Kelas AW dia. 110- 4"	1,20	77,90	M
				Perlengkapan Pipa PVC Kleas AW dia 110 (12.5%)	1,00	64,92	
A	LANTAI 2						
1	Pipa PVC Kelas AW (Incl. Fitting & Accessories) dia. 4"	M'	15	PVC Kelas AW dia. 110- 4"	1,20	18,00	M
				Perlengkapan Pipa PVC Kleas AW dia 110 (12.5%)	1,00	15,00	
III	PEMIPAAN AIR BEKAS						
A	LANTAI 1						
1	Pipa PVC Kelas AW (Incl. Fitting & Accessories) dia. 3"	M'	95,84	PVC Kelas AW dia. 75- 3"	1,20	115,01	M
				Perlengkapan Pipa PVC Kleas AW dia 75 (12.5%)	1,00	95,84	
A	LANTAI 2						

1	Pipa PVC Kelas AW (Incl. Fitting & Accessories) dia. 3"	M'	31,38	PVC Kelas AW dia. 75- 3"	1,20	37,66	M
				Perlengkapan Pipa PVC Kelas AW dia 75 (12.5%)	1,00	31,38	
IV	PEMIPAAN AIR HUJAN						
A	LANTAI 1						
1	Pipa PVC Kelas AW (Incl. Fitting & Accessories) dia. 4"	M'	22,96	PVC Kelas AW dia. 110- 4"	1,20	27,55	M
				Perlengkapan Pipa PVC Kelas AW dia 110 (12.5%)	1,00	22,96	
A	LANTAI 2						
1	Roof Drain	Buah	2	Roof Drain	1,00	2,00	Buah
V	INSTALASI KABEL FEEDER						
A	LANTAI 1						
1	NYM 3 x 4 mm ²	M'	41,8	power Cables NYM 4 x 4 mm	1,20	50,16	M
				Materil Bantu Kabel NYM 4x4(12.5%)	1,00	41,80	
B	LANTAI 2						
1	NYM 3 x 4 mm ²	M'	48,71	power Cables NYM 4 x 4 mm	1,20	58,45	M
				Materil Bantu Kabel NYM 4x4(12.5%)	1,00	48,71	
VI	INSTALASI KABEL TRAY						
A	LANTAI 1						
1	Pemasangan 1 m' Electronic Cable Tray size 150x50x3000x1 (2 mm)	M'	41,8	Cable Tray size 150x50x3000x1 (2 mm)	1,00	41,80	M
				Material Bantu Cable Tray size 150x40x3000x1 (12.5%)	1,00	41,80	
B	LANTAI 2						
1	Pemasangan 1 m' Electronic Cable Tray size 150x50x3000x1 (2 mm)	M'	48,71	Cable Tray size 150x50x3000x1 (2 mm)	1,00	48,71	M
				Material Bantu Cable Tray size 150x40x3000x1 (12.5%)	1,00	48,71	
VII	INSTALASI ARMATUR LAMPU, SAKLAR & STOP KONTAK						
A	LANTAI 1						
1	Lampu TL LED 2 x 14 Watt	Buah	35	Lampu TL LED 2 x 16 Watt	1,00	35,00	Buah

2	Lampu TL LED 14 Watt	Buah	4	Lampu TL LED 14 Watt	1,00	4,00	Buah
3	Lampu Bohlam LED 10 Watt	Buah	14	Lampu Bohlam LED 10 Watt	1,00	14,00	Buah
4	Saklar Tunggal 10A	Buah	10	Saklar 1 Gang	1,00	10,00	Buah
5	Saklar Seri 10A	Buah	8	Saklar 2 Gang	1,00	8,00	Buah
6	Stop Kontak 250 watt	Buah	23	Stop Kontak 250 watt	1,00	23,00	Buah
A	LANTAI 2						
1	Lampu TL LED 2 x 14 Watt	Buah	36	Lampu TL LED 2 x 16 Watt	1,00	36,00	Buah
2	Lampu TL LED 14 Watt	Buah	4	Lampu TL LED 14 Watt	1,00	4,00	Buah
3	Lampu Bohlam LED 10 Watt	Buah	14	Lampu Bohlam LED 10 Watt	1,00	14,00	Buah
4	Saklar Tunggal 10A	Buah	5	Saklar 1 Gang	1,00	5,00	Buah
5	Saklar Seri 10A	Buah	8	Saklar 2 Gang	1,00	8,00	Buah
6	Stop Kontak 250 watt	Buah	17	Stop Kontak 250 watt	1,00	17,00	Buah
VII	INSTALASI PENERANGAN & STOP KONTAK						
A	LANTAI 1						
1	NYA 3 x 2,5 mm ² + PVC Conduit dia.20 untuk Lampu	M'	532,47	NYA 3 x 2.5 mm ²	1,20	638,96	M
				PVC Conduit dia.20	1,00	532,47	M
2	NYA 3 x 2,5 mm ² + PVC Conduit dia.20 untuk Stop Kontak	M'	211,22	NYA 3 x 2.5 mm ²	1,20	253,46	M
				PVC Conduit dia.20	1,00	211,22	M
A	LANTAI 2						
1	NYA 3 x 2,5 mm ² + PVC Conduit dia.20 untuk Lampu	M'	537,987	NYA 3 x 2.5 mm ²	1,20	645,58	M
				PVC Conduit dia.20	1,00	537,99	M
2	NYA 3 x 2,5 mm ² + PVC Conduit dia.20 untuk Stop Kontak	M'	163,28	NYA 3 x 2.5 mm ²	1,20	195,94	M
				PVC Conduit dia.20	1,00	163,28	M
VIII	INSTALASI KABEL CCTV						

A	LANTAI 1						
1	Kabel Croaxial Tipe RG59	M'	100,056	Kabel Croaxial RG59	1,20	120,07	M
				Material Bantu Kabel Croaxial RG59(12.5%)	1,00	100,06	0
B	LANTAI 2						
1	Kabel Croaxial Tipe RG59	M'	98,7	Kabel Croaxial RG59	1,20	118,44	M
				Material Bantu Kabel Croaxial RG59(12.5%)	1,00	98,70	M
IX	INSTALASI KABEL CCTV						
A	LANTAI 1						
1	Kabel LAN untuk Wifi	M'	49,94	Kabel Lan	1,20	59,93	M
				Material Bantu Kabel LAN (12.5)	1,00	49,94	0
B	LANTAI 2						
1	Kabel LAN untuk Wifi	M'	45,44	Kabel Lan	1,20	54,53	M
				Material Bantu Kabel LAN (12.5)	1,00	98,70	0

