

## BAB 6

### KESIMPULAN DAN SARAN

#### 6.1. Kesimpulan

Dari hasil perancangan alat pengecoran kuningan dapat ditarik beberapa kesimpulan, yang dapat dilihat pada tabel 6.1.

Tabel 6.1. Spesifikasi tungku peleburan kuningan

<b>Spesifikasi</b>	<b>Tungku Peleburan kuningan</b>
Dimensi	Panjang = 800 mm Lebar = 500 mm Tinggi = 1005 mm
Bahan bakar	Briket batu bara
Material	Tungku = -Tong besi -Coran semen, fireclay, pasir (1 : 1 : 2) Trolley = Besi iser Ø 12 mm Besi as Ø 1 inch Pipa besi Ø 2 inch
Kapasitas lebur	10 Kg
Waktu lebur	105 menit
Tap-to-tap time	120 menit
Kebutuhan bahan bakar per peleburan	8 Kg batu bara 1 liter minyak tanah 577.5 watt listrik
Biaya Pembuatan Tungku	Rp 840.000,00
Biaya 1 Kali Peleburan	Rp 23.100,00

## **6.2. Saran**

Pada penelitian ini hanya membahas mengenai proses peleburan kuningan, dan belum membahas mengenai kualitas hasil cor dan cetakan yang dibutuhkan. Untuk penelitian dan pengembangan lebih lanjut disarankan untuk meneliti bagaimana membuat cetakan yang baik sehingga menghasilkan cor dengan kualitas yang baik.



## DAFTAR PUSTAKA

Cross, N., 1994, *Engineering Design Methods*, Second Edition, John Willey & Sons.

Groover, Mikell., 1996, *Fundamentals of modern Manufacturing Materials, Processes and System*, Prentice Hall.

Madyana, 1996, *Analisis Perancangan Kerja dan Ergonomi*, UAJY, Yogyakarta.

Surdia, Tata., Chijiwa, Kenji., 2006, *Teknik Pengecoran Logam*, PT. Pradnya Paramita, Jakarta.

Wongky Yudha, 1998, *Perencanaan Tungku Pengecoran Alumunium*, Skripsi, Program Studi Teknik Industri, Universitas Atma Jaya Yogyakarta, Yogyakarta.

Young, Hugh., Freedman, Roger., 2001, *Fisika universitas*, Erlangga, Jakarta.

[WWW.nuc.berkeley.edu](http://WWW.nuc.berkeley.edu), diakses tanggal 8 maret 2007.

<http://phoenix.phys.clemson.edu>, diakses tanggal 8 maret 2007.

# LAMPIRAN



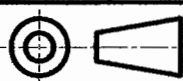

<i>Revision Index</i>	<i>Drawn by</i> : CHRISTIAN		<i>Scale</i> : 1 : 5	
	<i>Reg. Nr.</i> : -		<i>Unit</i> : mm	
	<i>Date</i> : 22 APRIL 2007		<i>Material</i> : -	
	<i>Checked by</i> : T.B. Hanandaka S.T., M.T.		<i>Sign</i> :	
	<b>A4</b>	<b>TUNGKU PELEBURAN KUNINGAN</b>		
<b>INDUSTRIAL ENGINEERING UAJY</b>		<i>Operation</i>		<i>Dwg. Nr.</i>
<i>Origin.</i>	<i>Rep.</i>	<i>Rep.by.</i>	<i>SN. NS.</i>	

NO	DISCRPTION	MATERIAL	QTY	REMARK
1	TUAS	PIPA HITAM	1	
2	RANGKA BELAKANG	EISER Ø 12	1L/1R	
3	PENGUAT RANGKA	EISER Ø 12	2	
4	RANGKA ATAS	EISER Ø 12	1	
5	RANGKA DEPAN	EISER Ø 12	1	
6	RANGKA BAWAH	EISER Ø 12	1	
7	BATANG PENGUNCI	EISER Ø 12	1	
8	PENGUNCI ATAS	EISER Ø 12	1	
9	PENGUNCI BAWAH	EISER Ø 12	1	
10	LENGKUN AYUN	EISER Ø 12	1L/1R	
11	DUDUKAN BLOWER	PLAT STRIP 5x50	1	
12	GANTUNGAN TUTUP	PLAT 2.5"x60mm	1	
13	GANTUNGAN AYUN	PLAT 2.5"x60mm	1	
14	TUNGKU	CORAN	1	
15	TUTUP TUNGKU	CORAN	1	
16	KOWI	PIPA BESI	1	
17	PENGANGKAT KOWI	EISER Ø 12	1	
18	PENJANG KOWI	EISER Ø 12	1	
19	ENGSEL	PIPA HITAM Ø 1/2"	1	
20	BASE RODA	BESI AS Ø 1"	1	
21	BASE ENGSEL	BESI AS Ø 1"	1	

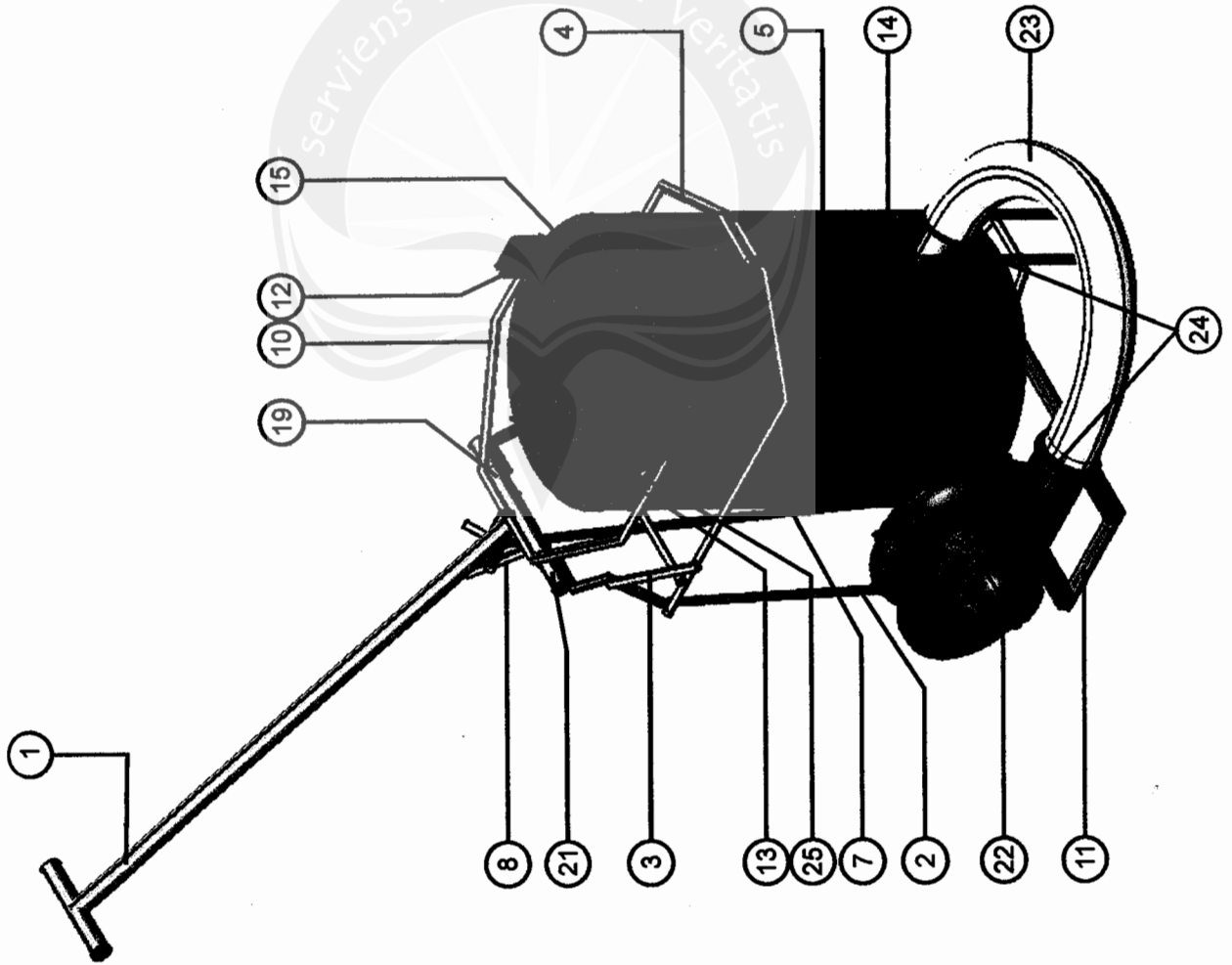

Revisi No. : 00	Drawn by : CHRISTIAN	Scale : 1 : 1.5
Reg. No. : --	Date : 22 APRIL 2007	Unit : mm
Checked by : T.R. Hanudata S.T., A.T. Sign :		Material : --
A4 ASSEMBLY		Dwg. No. :
INDUSTRIAL ENGINEERING		Dep. by :
UATY		Origin :
SN. :		NS. :

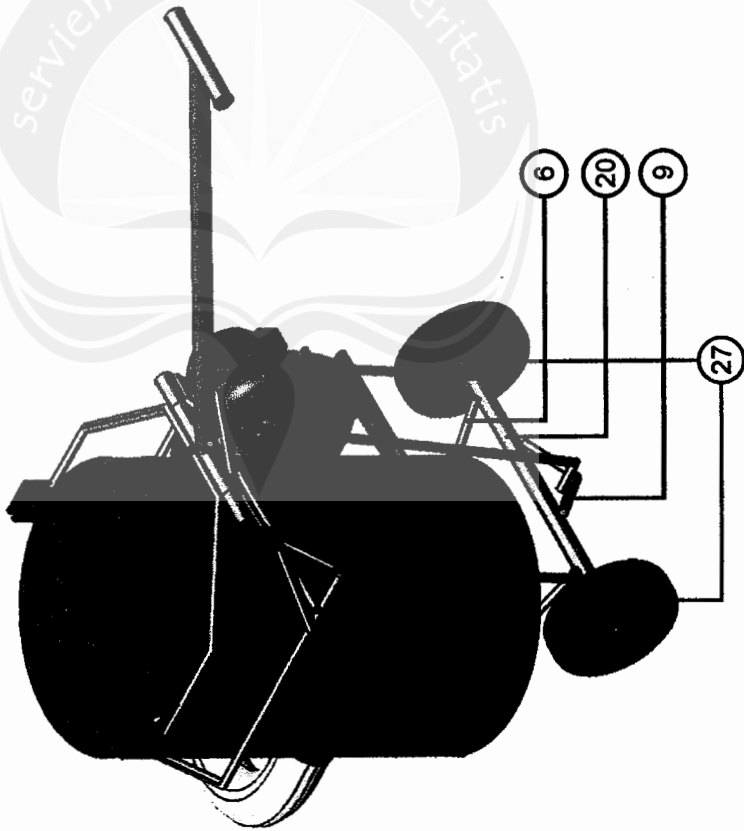

NO	DISCRPTION	MATERIAL	QTY	REMARK
1	TIAS	PIPA HITAM	1	
2	RANGKA BELAKANG	EISER Ø 12	1L/1R	
3	PENGUAT RANGKA	EISER Ø 12	2	
4	RANGKA ATAS	EISER Ø 12	1	
5	RANGKA DEPAN	EISER Ø 12	1	
6	RANGKA BAWAH	EISER Ø 12	1	
7	BATANG PENGUNCI	EISER Ø 12	1	
8	PENGUNCI ATAS	EISER Ø 12	1	
9	PENGUNCI BAWAH	EISER Ø 12	1	
10	LENGKUN AYUN	EISER Ø 12	1L/1R	
11	DUDUKAN BLOWER	PLAT STRIP S450	1	
12	GANTUNGAN TUTUP	PLAT 2.5*60mm	1	
13	GANTUNGAN AYUN	PLAT 2.5*60mm	1	
14	TUNGKU	CORAN	1	
15	TUTUP TUNGKU	CORAN	1	
16	KOWI	PIPA BESI	1	
17	PENANGKAT KOWI	EISER Ø 12	1	
18	PENJANG KOWI	EISER Ø 12	1	
19	ENGSEL	PIPA HITAM Ø 1.5"	1	
20	BASE RODA	BESI AS Ø 1"	1	
21	BASE ENGSEL	BESI AS Ø 1"	1	

DRAWING TITLE		Drawn by : CHRISTIAN	Scale : 1 : 1.5
Draw. No. :		Date : 22 APRIL 2007	Unit : mm
Checked by : T.R. HANINDHA S.T. M.T. SIGN :		Revisi : -	
A4		ASSEMBLY	
INDUSTRIAL ENGINEERING		Dwg. No.	
LULY		Rep. by.	
Origin.		SN. MS.	

NO	NAME	MATERIAL	PIECES	REVISION
1	TUAS	PIPA HITAM	1	
2	RANGKA BELAKANG	EISER Ø 12	1L/1R	

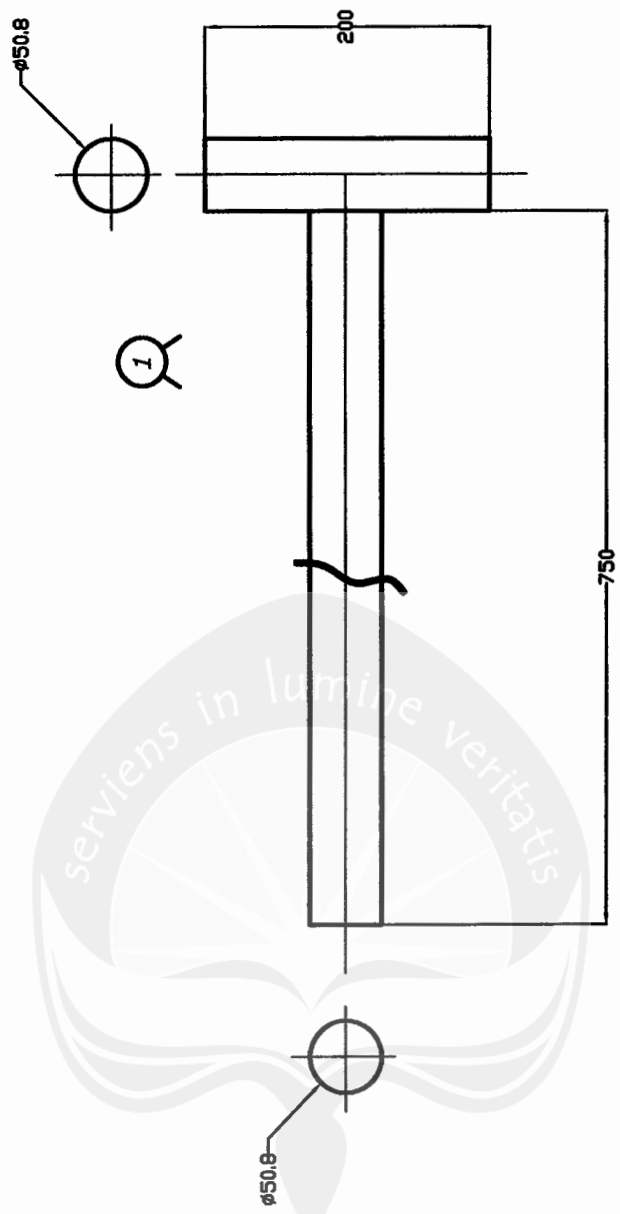
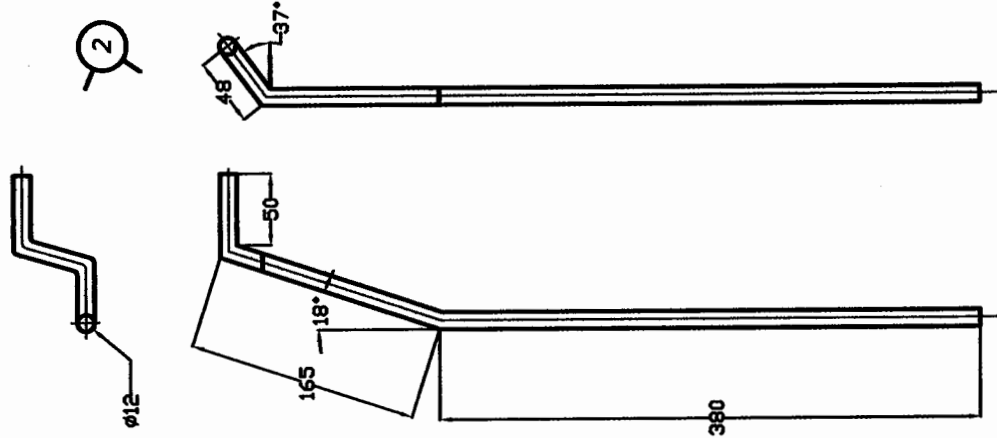

Revision Index		Drawn by : CRHISTIAN	Scale : 1 : 5
		Reg. Nr. : -	Unit : mm
		Date : 22 APRIL 2007	Material : -
		Checked by : -	Sign : -
INDUSTRIAL ENGINEERING UAJU		PART 1-2	
Origin.		Rep.	Dwg. Nr.
Rep.		Rep.by.	SN. NS.



NO	NAME	MATERIAL	PIECES	REVISION
3	PENGUAT RANGKA	EISER Ø 12	2	
4	RANGKA ATAS	EISER Ø 12	1	
5	RANGKA DEPAN	EISER Ø 12	1	

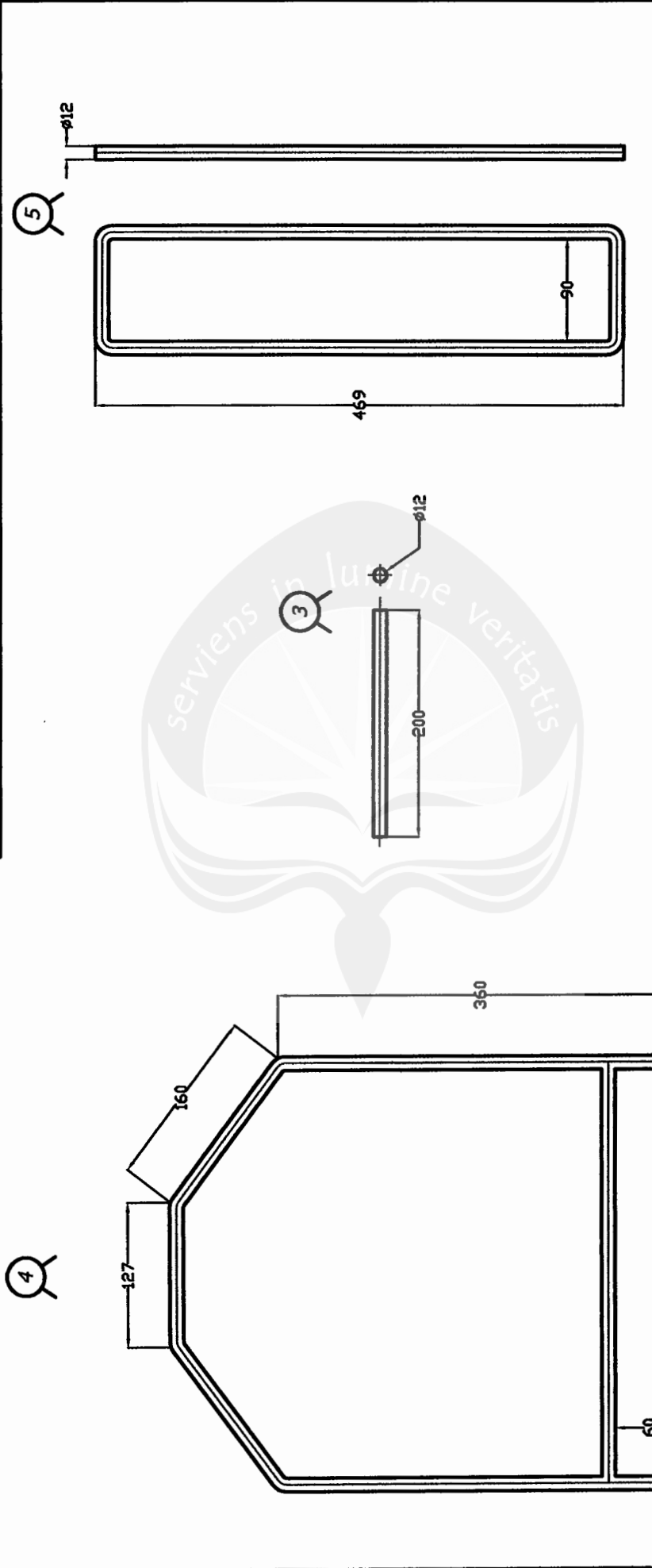

Revision Index		Drawn by : CRHISTIAN	Scale : 1 : 5
		Reg. Nr. : -	Unit : mm
		Date : 22 APRIL 2007	Material : -
		Checked by : -	Sign :
INDUSTRIAL ENGINEERING UAJY		PART 3-5	
Origin.		Rep.by.	SN. NS.

NO	NAME	MATERIAL	PIECES	REVISION
6	RANGKA BAWAH		1	
7	BATANG PENGUNCI		1	

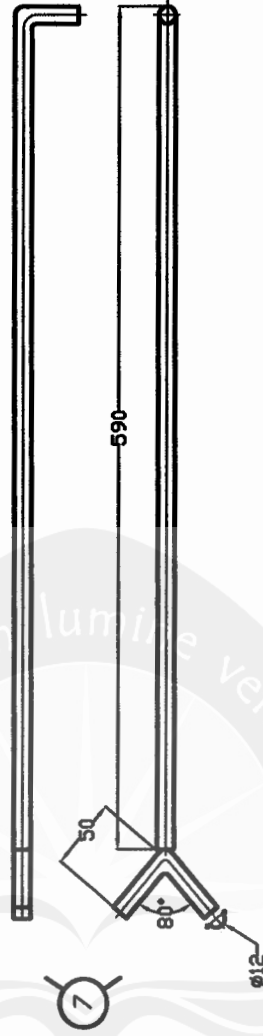
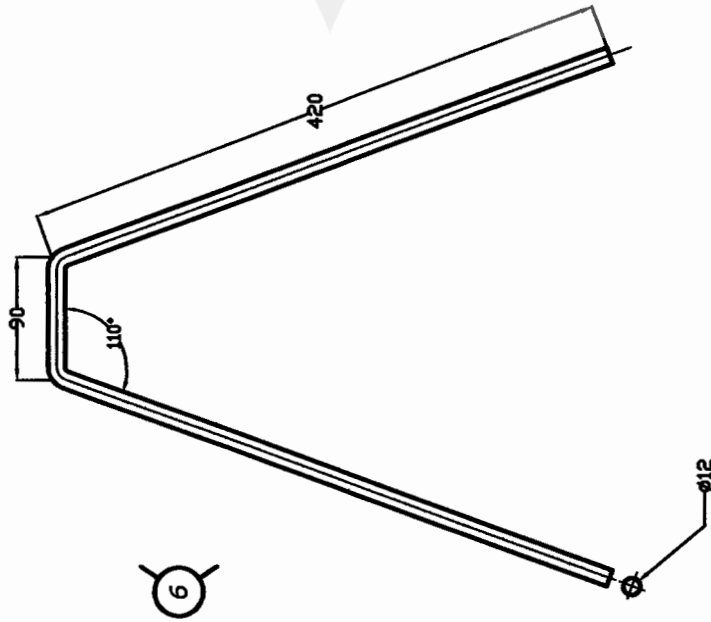

Revision Index		Drawn by : CRHISTIAN	Scale : 1 : 5
		Reg. Nr. : -	Unit : mm
		Date : 22 APRIL 2007	Material : -
		Checked by : -	Sign :
A4		PART 6-7	
INDUSTRIAL ENGINEERING UAJU		Operation	Dwg. Nr.
Origin.	Rep.	Rep.by.	SN. NS.

NO	NAME	MATERIAL	PIECES	REVISION
8	PENGUNCI ATAS	EISER Ø 12	1	
9	PENGUNCI BAWAH	EISER Ø 12	1	
10	LENGAN AYUN	EISER Ø 12	1L/1R	
11	DUDUKAN BLOWER	PLAT STRIP 5x50	1	

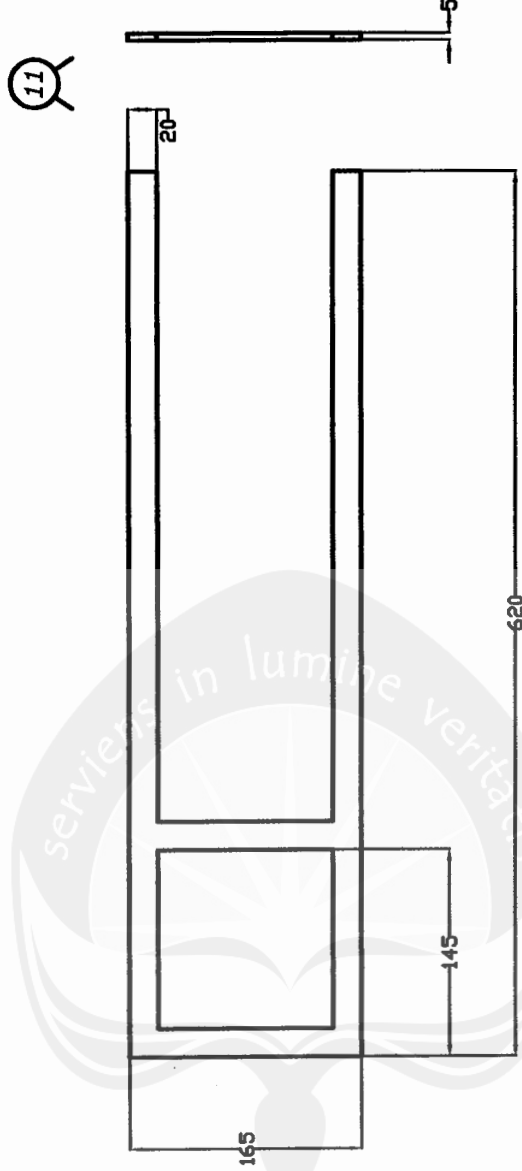
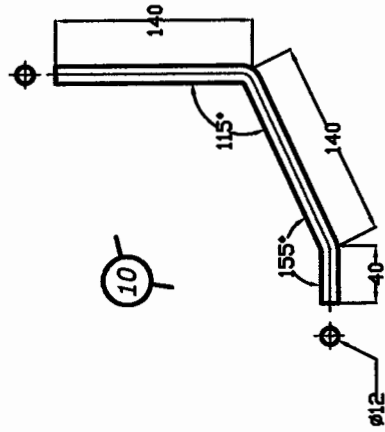
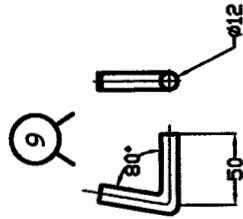
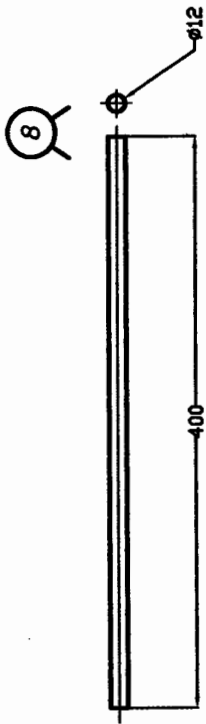

Revision Index		Drawn by : CRHISTIAN	Scale : 1 : 5
		Reg. Nr. : -	Unit : mm
		Date : 22 APRIL 2007	Material : -
		Checked by : -	Sign : -
A4		PART 8-11	
INDUSTRIAL ENGINEERING UAJY	Operation	Dwg. Nr.	
Origin.	Rep.	Rep.by.	SN. NS.

NO	NAME	MATERIAL	PIECES	REVISION
12	GANTUNGAN TUTUP	PLAT 2.5"x6mm	1	
13	GANTUNGAN AYUN	PLAT 2.5"x6mm	1	
17	PENGANGKAT KOWI	EISER Ø 12	1	
18	PENUANG KOWI	EISER Ø 12	1	
19	ENGSEL	PIPA HITAM Ø 1½"	1	
20	BASE RODA	BESI AS Ø 1"	1	
21	BASE ENGSEL	BESI AS Ø 1"	1	

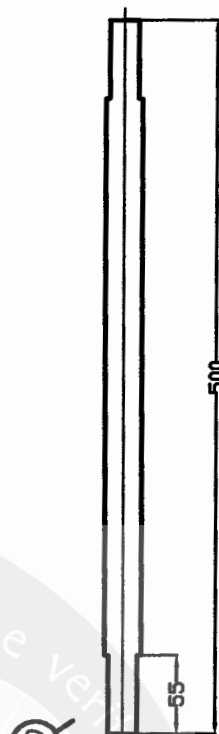
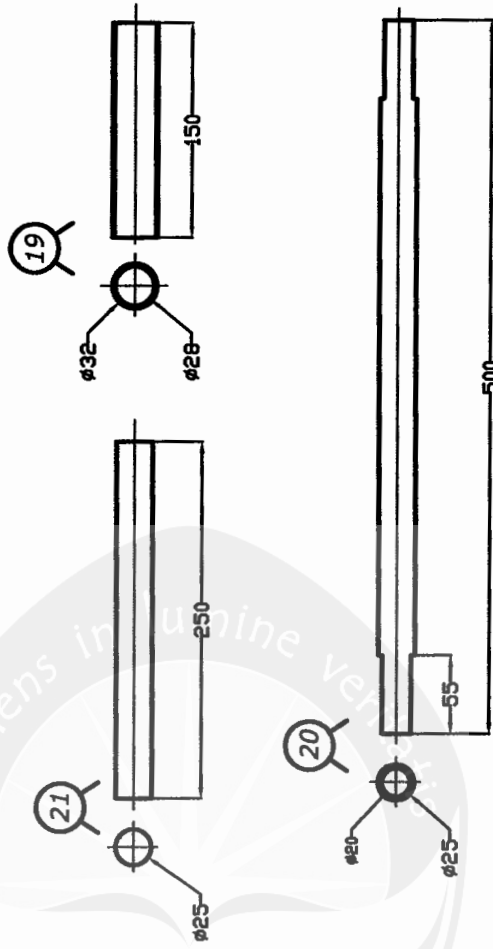
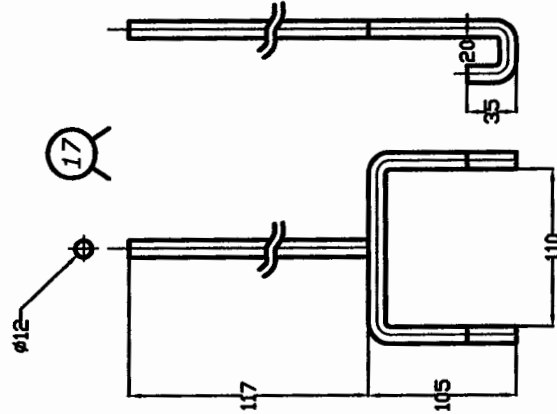
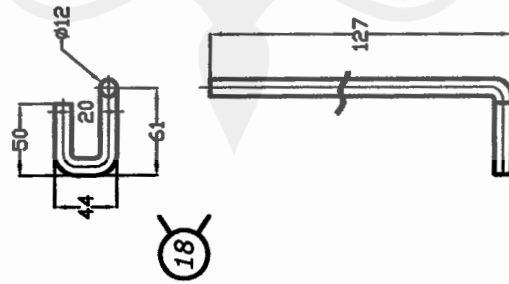
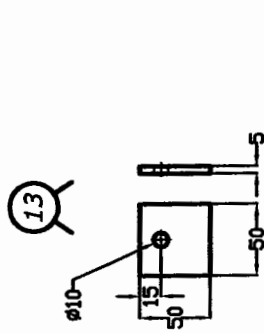
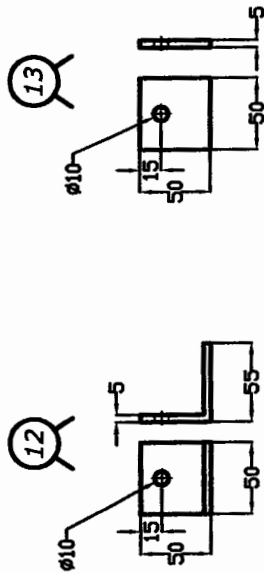

Revision Index		Drawn by : CRHISTIAN	Scale : 1 : 5
		Reg. Nr. : -	Unit : mm
		Date : 22 APRIL 2007	Material : -
		Checked by : -	Sign :
A4		PART 12-13, 17-21	
INDUSTRIAL ENGINEERING UAJY		Operation	Dwg. Nr.
Origin.	Rep.	Rep.by.	SN. NS.

NO	NAME	MATERIAL	PIECES	REVISION
14	TUNGKU	CORAN	1	
15	TUTUP TUNGKU	CORAN	1	
16	KOWI	PIPA BESI	1	

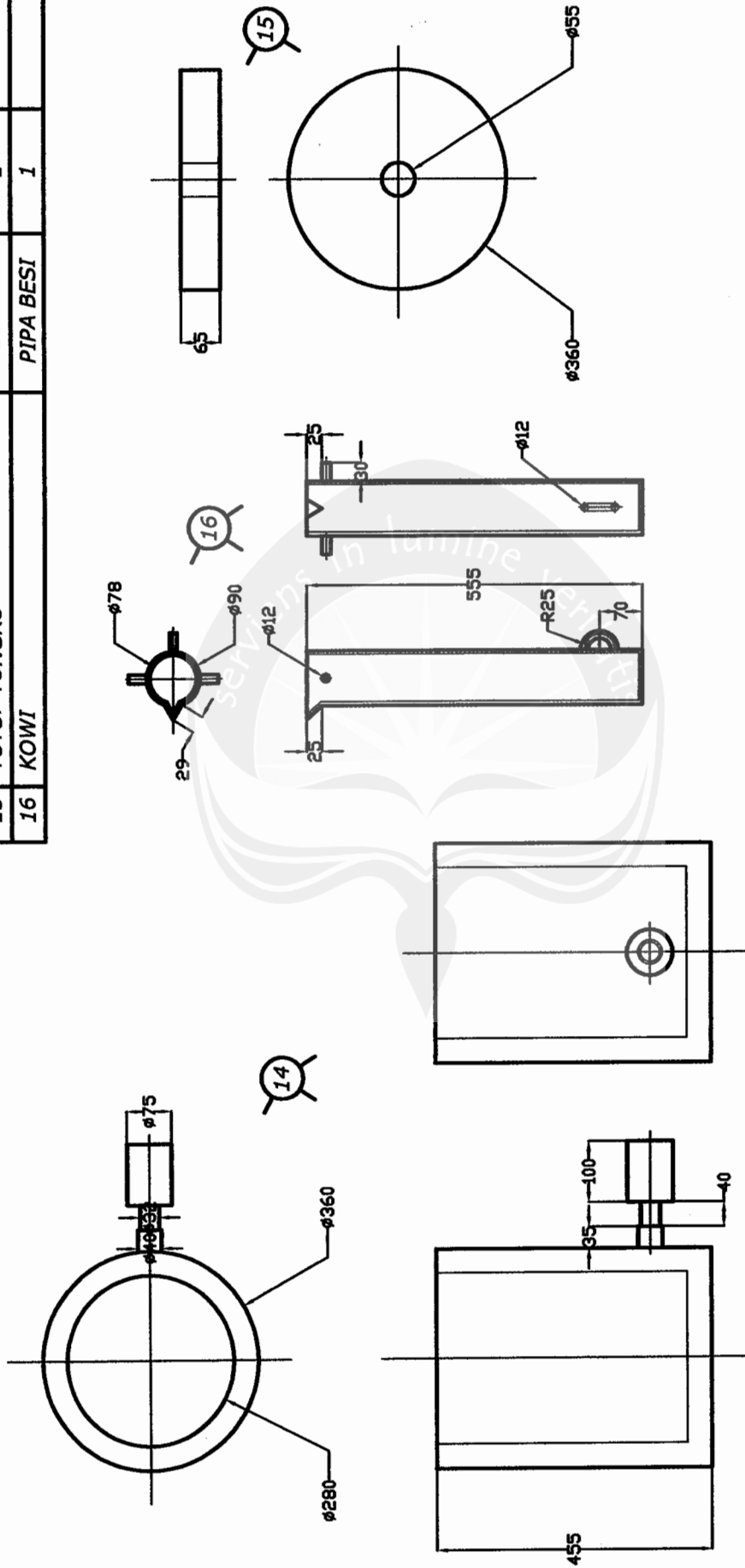

Revision Index	Drawn by : CHRISTIAN	Scale : 1 : 10
	Reg. Nr. : -	Unit : mm
	Date : 22 APRIL 2007	Material : -
	Checked by : -	Sign : -
A4		PART 14-16
INDUSTRIAL ENGINEERING UAJY	Operation	Dwg. Nr.
Origin.	Rep.by.	SN. NS.

### Uji keseragaman data TSB

$$k = 1 + 3.3 \log N$$

$$N = 15$$
$$k = 4,8811 = 5$$

subgrup	Data (Xi)			Rata2	Ket
1	100,0	100,0	105,0	101,7	seragam
2	105,0	107,0	102,0	104,7	seragam
3	108,0	100,0	107,0	105,0	seragam
4	105,0	105,0	106,0	105,3	seragam
5	109,0	107,0	109,0	108,3	seragam
Jumlah Rata2Subgrup				525,0	

Rata2 subgroup	105,00
SD	3,1396
SD rata2	1,8127
BKA	110,44
BKB	99,56
Keterangan	Data seragam

### Uji kecukupan data TSB

	%	Nilai
Keyakinan	95	2
ketelitian	5	0.05
K/S	#VALUE!	

N hitung = #VALUE!  
Keterangan = #VALUE!

Xi	Xi <sup>2</sup>	Xi-Xbar	(Xi-Xbar) <sup>2</sup>
		-	
100,0	10000,00	5,0000	25,0000
		-	
100,0	10000,00	5,0000	25,0000
105,0	11025,00	0,0000	0,0000
105,0	11025,00	0,0000	0,0000
107,0	11449,00	2,0000	4,0000
		-	
102,0	10404,00	3,0000	9,0000
108,0	11664,00	3,0000	9,0000
		-	
100,0	10000,00	5,0000	25,0000
107,0	11449,00	2,0000	4,0000
105,0	11025,00	0,0000	0,0000
105,0	11025,00	0,0000	0,0000
106,0	11236,00	1,0000	1,0000
109,0	11881,00	4,0000	16,0000
107,0	11449,00	2,0000	4,0000
109,0	11881,00	4,0000	16,0000
			138,0000

data Xi <sup>2</sup>		
10000,0	10000,0	11025,0
11025,0	11449,0	10404,0
11664,0	10000,0	11449,0
11025,0	11025,0	11236,0
11881,0	11449,0	11881,0
Jmlh Xi <sup>2</sup>		165513,0
Jmlh Xi		1575,0
(Jmlh Xi <sup>2</sup> )		2480625,0

Percentil 5%                    100  
 Percentil 50%                   105  
 Percentil 95%                   109

## Uji Kenormalan Data

### One-Sample Kolmogorov-Smirnov Test

		TSB
N		15
Normal Parameters <sup>a,b</sup>	Mean	105,00
	Std. Deviation	3,140
Most Extreme Differences	Absolute	,233
	Positive	,144
	Negative	-,233
Kolmogorov-Smirnov Z		,904
Asymp. Sig. (2-tailed)		,388

a. Test distribution is Normal.

b. Calculated from data.

