

BAB 6

KESIMPULAN DAN SARAN

6.1. Kesimpulan

Melihat dari ketersediaan mesin di lantai produksi, waktu produksi tersedia tiap bulan, waktu produksi yang dibutuhkan, dan jumlah mesin yang harus dioperasikan, dapat dibuat kebijakan terkait kapasitas produksi, yaitu:

- a. Tanpa menggunakan tambahan waktu lembur dan dengan mengoperasikan seluruh mesin yang tersedia, kapasitas produksi egrek maksimum yang dapat dibuat oleh perusahaan adalah 600 unit/bulan.
- b. Dengan tambahan waktu lembur (maksimal 2 jam/hari kerja) dan dengan mengoperasikan seluruh mesin yang tersedia, kapasitas produksi egrek maksimum yang dapat dibuat oleh perusahaan adalah 800 unit/bulan.
- c. Kebutuhan mesin dapat dilihat pada Tabel 5.52. dan Tabel 5.53

6.2. Saran

Jumlah pesanan yang melebihi kondisi yang terdapat pada poin a dan b pada sub-bab 6.1 dapat diterima dengan syarat harus dilakukan pemerataan beban produksi tiap bulan atau disubkontrakkan. Penelitian selanjutnya dapat dilakukan dengan mempertimbangkan aspek biaya, hal ini termasuk perhitungan biaya langsung maupun biaya *overhead*. Penelitian selanjutnya juga dapat dilakukan dengan mempertimbangkan adanya produk lain yang diproduksi di lantai produksi yang sama.

Perencanaan perawatan mesin juga dapat menjadi alternatif pengembangan dari penelitian ini.



DAFTAR PUSTAKA

- Ahyari, A., Drs., 1986, *Manajemen Produksi, Perencanaan Sistem Produksi Buku I*; BPFE, Yogyakarta.
- Arifin, Miftahol, 2009, *Simulasi Sistem Industri*, Graha Ilmu, Yogyakarta.
- Baroto, T., 2002, *Perencanaan dan Pengendalian Produksi*, Ghalia Indonesia, Yogyakarta.
- Djati, B.S.L., 2007, *Simulasi Teori dan Aplikasinya*, Andi, Yogyakarta.
- Gasperstz, V., MST., 1998, *Production Planning and Inventory Control, Berdasarkan Pendekatan Sistem Terintegrasi MRP II dan JIT menuju Manufacturing 21, PPIC*, Vincent Foundation, PT. Gramedia Pustaka Utama, Jakarta.
- Gitosudarmo, I., Drs., 1985, *Sistem Perencanaan dan Pengendalian Produksi*, BPFE, Yogyakarta.
- Groover, M., P., 2001, *Automation, Production Systems, and Computer Integrated Manufacturing*, Prentice Hall of India, New Delhi.
- Gujarathi, Nikhil S., Rohit M. Ogale, Tarun Gupta, 2004, *Production Capacity Analysis of a Shock Absorber Assembly Line Using Simulation*, Proceedings of the 2004 Winter Simulation Conference.
- Handoko, Drs. T. Hani, 1984, *Dasar-Dasar Manajemen Produksi dan Operasi*, BPFE, Yogyakarta.
- Kakiay, Thomas J., 2004, *Dasar Teori Antrian untuk Kehidupan Nyata*, Andi, Yogyakarta.

- Kelton, W.D., Randall P. Sadowski, David T. Sturrock, 2007, *Simulation with Arena 4th Edition*, McGraw Hill Companies Inc., New York.
- Law, A.M., W. David Kelton, 2000, *Simulation Modeling and Analysis 3rd Edition*, McGraw Hill Companies Inc., New York.
- Marvel, Jon H., Mark A. Schaub, Gary Weckman, 2005, *Validating the Capacity Planning Process and Flowline Product Sequencing Through Simulation Analysis*, Proceedings of the 2005 Winter Simulation Conference.
- Narasimhan, Sim, Dennis W. McLeavey, Peter Billington, 1995, *Production Planning and Inventory Control 2nd Edition*, Prentice-Hall Inc., New Jersey
- Silver, Edward A., David E. Pyke, Rein Peterson, 1998, *Inventory Management and Production Planning and Scheduling*, John Wiley & Sons, United States of America.
- Sumayang, Lalu, 2003, *Dasar-Dasar Manajemen Produksi & Operasi*, Salemba Empat, Jakarta.
- Widodo, Stefanus -K., 2007, *Penentuan Jumlah Ketersediaan VCD yang Optimum dengan Simulasi (Studi Kasus di Paris van Movie Disc)*, Skripsi, Program Studi Teknik Industri, Fakultas Teknik Industri, Universitas Atma Jaya Yogyakarta.



serviens in lumine veritatis

Lampiran A

Distribusi Data Proses Tempa

Distribusi Waktu Proses Pemotongan Bahan

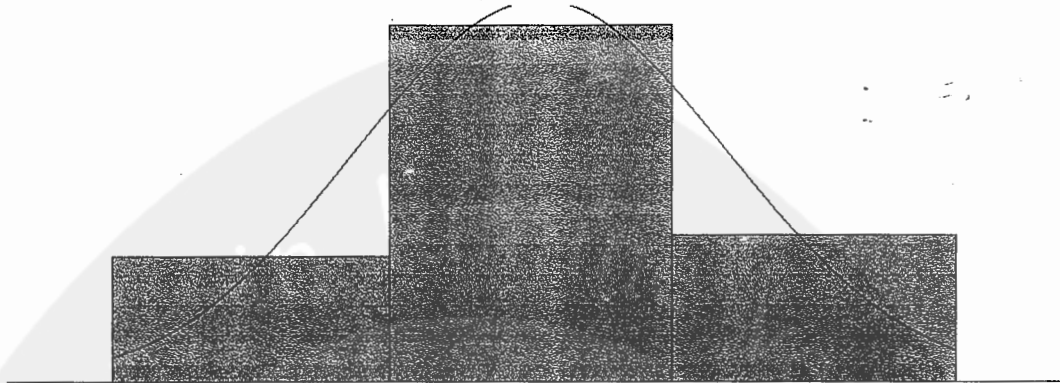

Distribution Summary

Distribution: Normal
Expression: NORM(7.03,
0.657)
Square Error: 0.000256

Data Summary

Number of Data Points = 30
Min Data Value = 6
Max Data Value = 8
Sample Mean = 7.03
Sample Std Dev = 0.669

Chi Square Test

Number of intervals = 3
Degrees of freedom = 0
Test Statistic = 0.0182
Corresponding p-value < 0.005

Histogram Summary

Histogram Range = 5.5 to
8.5
Number of Intervals = 3

Distribusi Waktu Proses Heating 1

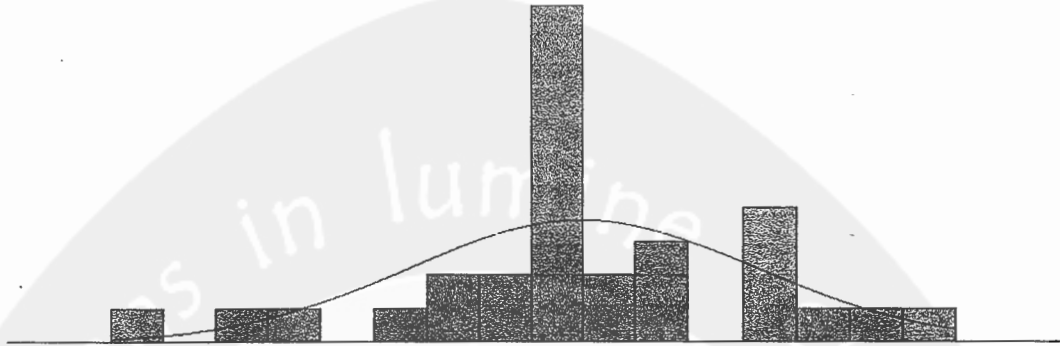

Distribution Summary

Distribution: Normal
 Expression: NORM(216, 3.29)
 Square Error: 0.068628

Data Summary

Number of Data Points = 30
 Min Data Value = 208
 Max Data Value = 223
 Sample Mean = 216
 Sample Std Dev = 3.35

Chi Square Test

Number of intervals = 4
 Degrees of freedom = 1
 Test Statistic = 5.85
 Corresponding p-value = 0.0173

Histogram Summary

Histogram Range = 208 to 224
 Number of Intervals = 16

Distribusi Waktu Proses Rek Kedua Ujung

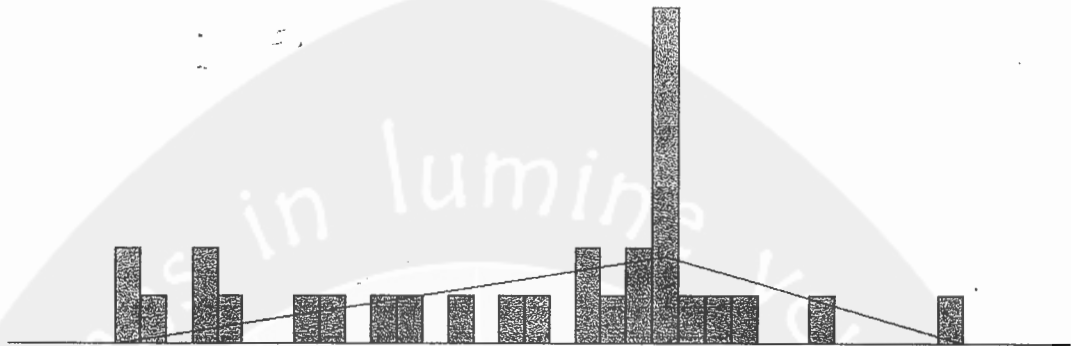

Distribution Summary

Distribution: Triangular
 Expression: TRIA(267, 288,
 300)
 Square Error: 0.052675

Data Summary

Number of Data Points = 30
 Min Data Value = 267
 Max Data Value = 299
 Sample Mean = 282
 Sample Std Dev = 8.66

Chi Square Test

Number of intervals = 5
 Degrees of freedom = 3
 Test Statistic = 13.2
 Corresponding p-value <
 0.005

Histogram Summary

Histogram Range = 267 to
 300
 Number of Intervals = 33

Distribusi Waktu Proses Heating 2

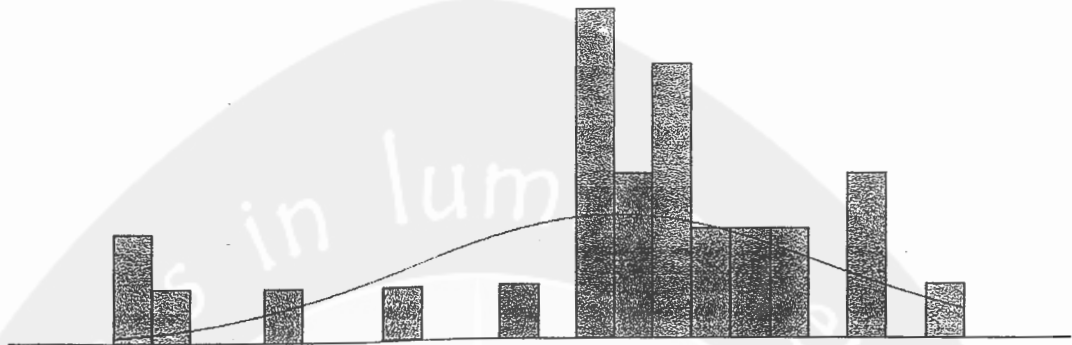

Distribution Summary

Distribution: Normal
Expression: NORM(217, 5.3)
Square Error: 0.052131

Chi Square Test

Number of intervals = 4
Degrees of freedom = 1
Test Statistic = 12.6
Corresponding p-value <
0.005

Data Summary

Number of Data Points = 30
Min Data Value = 204
Max Data Value = 225
Sample Mean = 217
Sample Std Dev = 5.39

Histogram Summary

Histogram Range = 204 to
226
Number of Intervals = 22

Distribusi Waktu Proses Bending

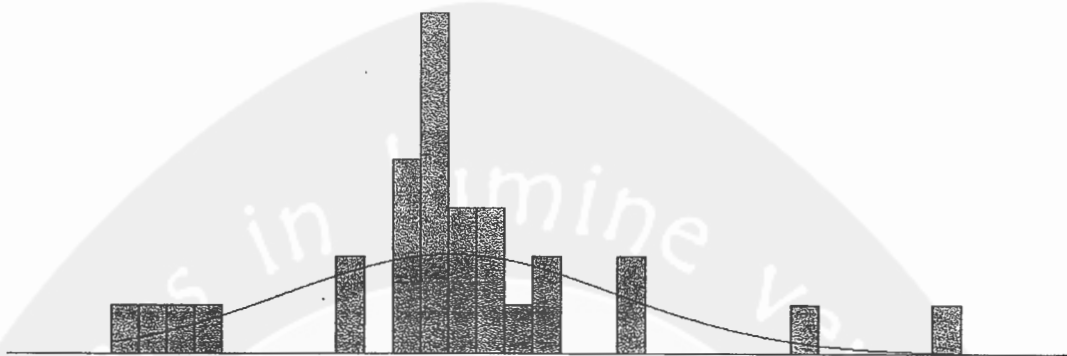

Distribution Summary

Distribution: Normal
Expression: NORM(217, 5.85)
Square Error: 0.056276

Data Summary

Number of Data Points = 30
Min Data Value = 205
Max Data Value = 234
Sample Mean = 217
Sample Std Dev = 5.95

Chi Square Test

Number of intervals = 5
Degrees of freedom = 2
Test Statistic = 16.6
Corresponding p-value < 0.005

Histogram Summary

Histogram Range = 205 to 235
Number of Intervals = 30

Distribusi Waktu Proses Heating 3

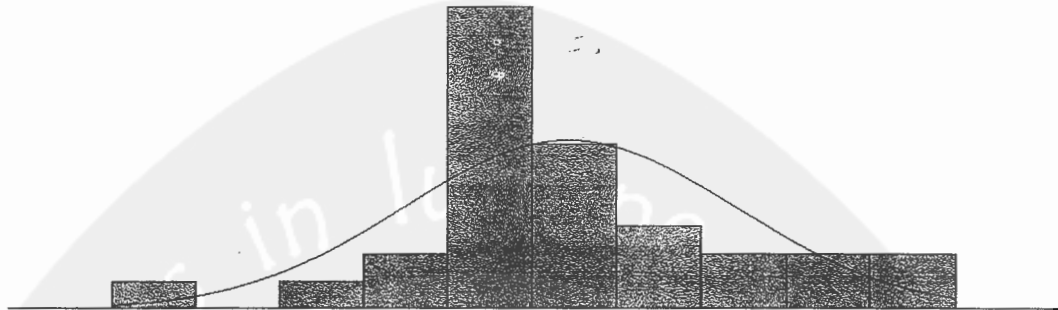

Distribution Summary

Distribution: Normal
 Expression: NORM(18.9, 1.95)
 Square Error: 0.050351

Data Summary

Number of Data Points = 30
 Min Data Value = 14
 Max Data Value = 23
 Sample Mean = 18.9
 Sample Std Dev = 1.98

Chi Square Test

Number of intervals = 5
 Degrees of freedom = 2
 Test Statistic = 8.18
 Corresponding p-value = 0.0184

Histogram Summary

Histogram Range = 13.5
 to 23.5
 Number of Intervals = 10

Distribusi Waktu Proses Forming 1

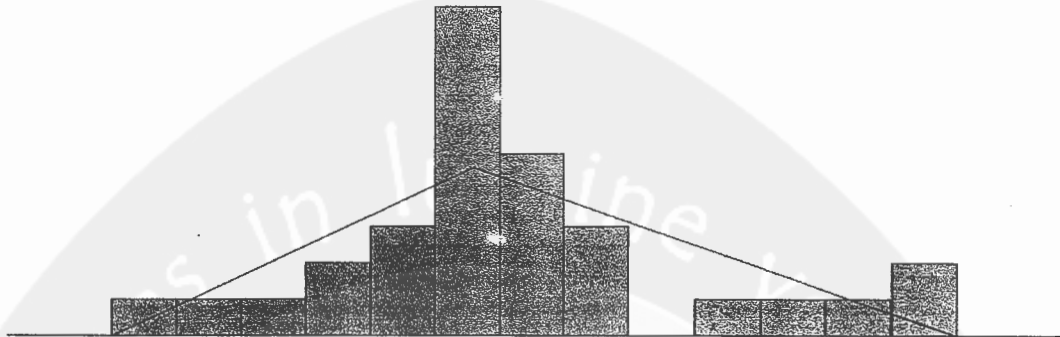

Distribution Summary

Distribution: Triangular
 Expression: $TRIA(12.5, 18, 25.5)$
 Square Error: 0.041486

Data Summary

Number of Data Points = 30
 Min Data Value = 13
 Max Data Value = 25
 Sample Mean = 18.7
 Sample Std Dev = 2.87

Chi Square Test

Number of intervals = 4
 Degrees of freedom = 2
 Test Statistic = 6.43
 Corresponding p-value = 0.0421

Histogram Summary

Histogram Range = 12.5 to 25.5
 Number of Intervals = 13

Distribusi Waktu Proses Forming 2

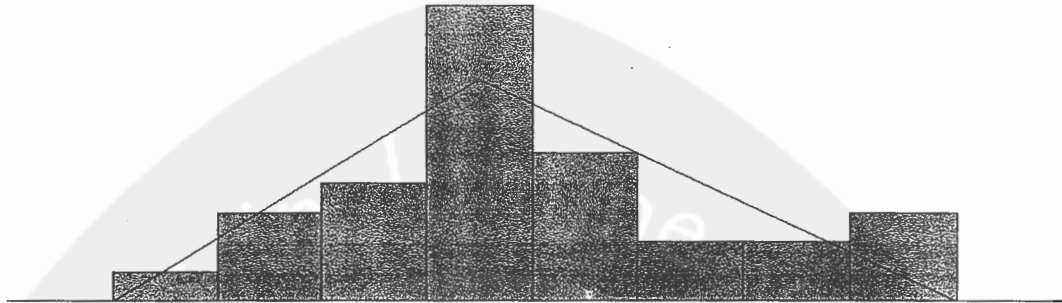

Distribution Summary

Distribution: Triangular
 Expression: $TRIA(14.5, 18, 22.5)$
 Square Error: 0.023427

Chi Square Test

Number of intervals = 4
 Degrees of freedom = 2
 Test Statistic = 2.76
 Corresponding p-value = 0.252

Data Summary

Number of Data Points = 30
 Min Data Value = 15
 Max Data Value = 22
 Sample Mean = 18.5
 Sample Std Dev = 1.83

Histogram Summary

Histogram Range = 14.5 to 22.5
 Number of Intervals = 8

Distribusi Waktu Proses Trimming

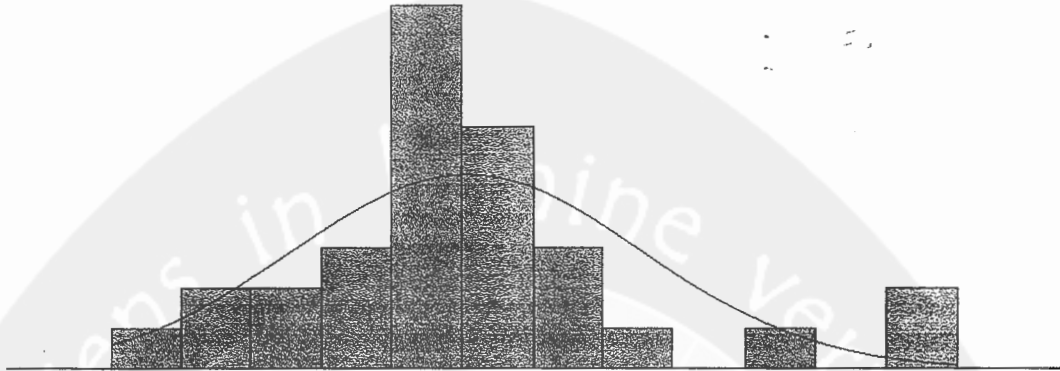

Distribution Summary

Distribution: Normal
 Expression: NORM(18.6, 2.49)
 Square Error: 0.037974

Data Summary

Number of Data Points = 30
 Min Data Value = 14
 Max Data Value = 25
 Sample Mean = 18.6
 Sample Std Dev = 2.53

Chi Square Test

Number of intervals = 4
 Degrees of freedom = 1
 Test Statistic = 4.87
 Corresponding p-value = 0.0283

Histogram Summary

Histogram Range = 13.5 to 25.5
 Number of Intervals = 12

Distribusi Waktu Proses Heating 4

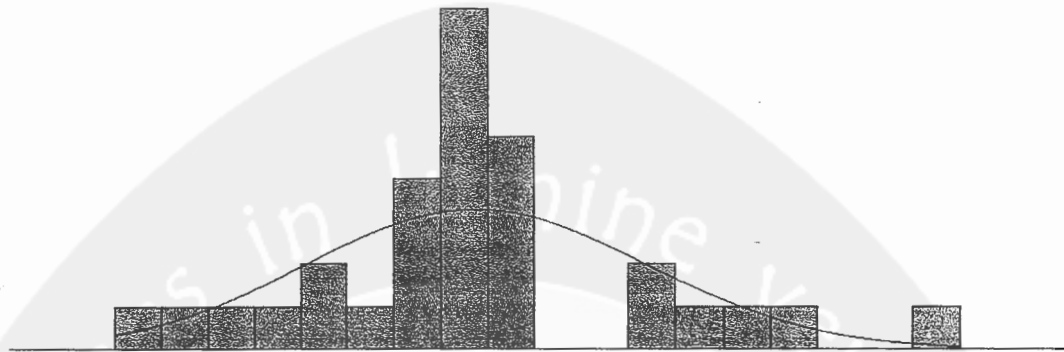

Distribution Summary

Distribution: Normal
Expression: $NORM(108, 3.64)$
Square Error: 0.051210

Data Summary

Number of Data Points = 30
Min Data Value = 101
Max Data Value = 118
Sample Mean = 108
Sample Std Dev = 3.7

Chi Square Test

Number of intervals = 5
Degrees of freedom = 2
Test Statistic = 12.1
Corresponding p-value < 0.005

Histogram Summary

Histogram Range = 101 to 119
Number of Intervals = 18

Distribusi Waktu Proses Tekuk Bagian Ujung

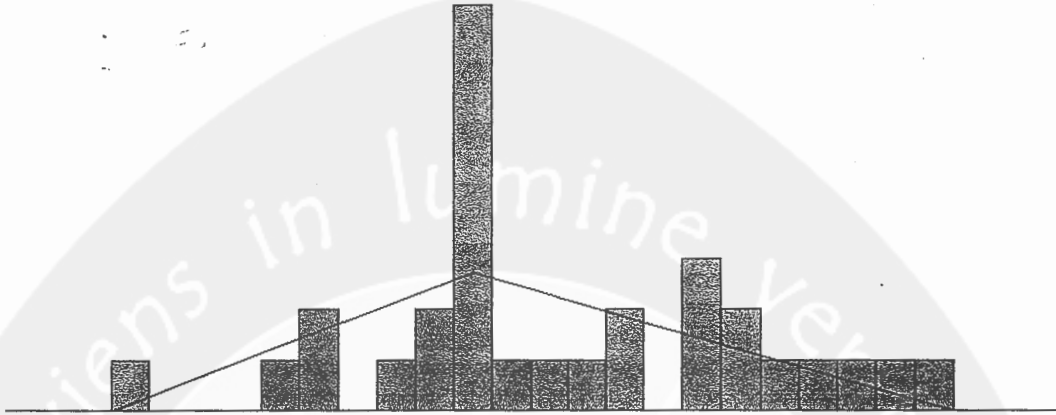

Distribution Summary

Distribution: Triangular
 Expression: TRIA(423, 432,
 445)
 Square Error: 0.054031

Data Summary

Number of Data Points = 30
 Min Data Value = 423
 Max Data Value = 444
 Sample Mean = 434
 Sample Std Dev = 5.06

Chi Square Test

Number of intervals = 5
 Degrees of freedom = 3
 Test Statistic = 7.15
 Corresponding p-
 value = 0.0711

Histogram Summary

Histogram Range = 423 to
 445
 Number of Intervals = 22

Distribusi Waktu Proses Straightening

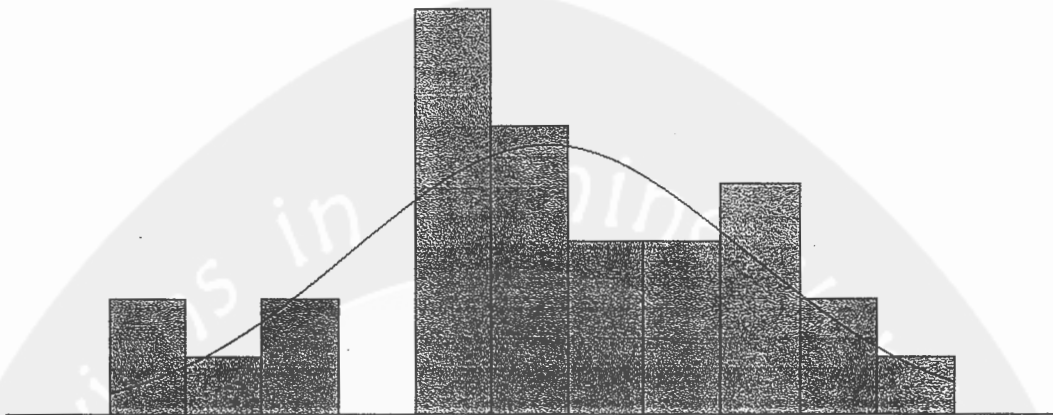

Distribution Summary

Distribution: Normal
 Expression: $NORM(15.2, 2.56)$
 Square Error: 0.027974

Chi Square Test

Number of intervals = 4
 Degrees of freedom = 1
 Test Statistic = 3.13
 Corresponding p-value = 0.0815

Data Summary

Number of Data Points = 30
 Min Data Value = 10
 Max Data Value = 20
 Sample Mean = 15.2
 Sample Std Dev = 2.61

Histogram Summary

Histogram Range = 9.5 to 20.5
 Number of Intervals = 11

Distribusi Waktu Proses Inspeksi

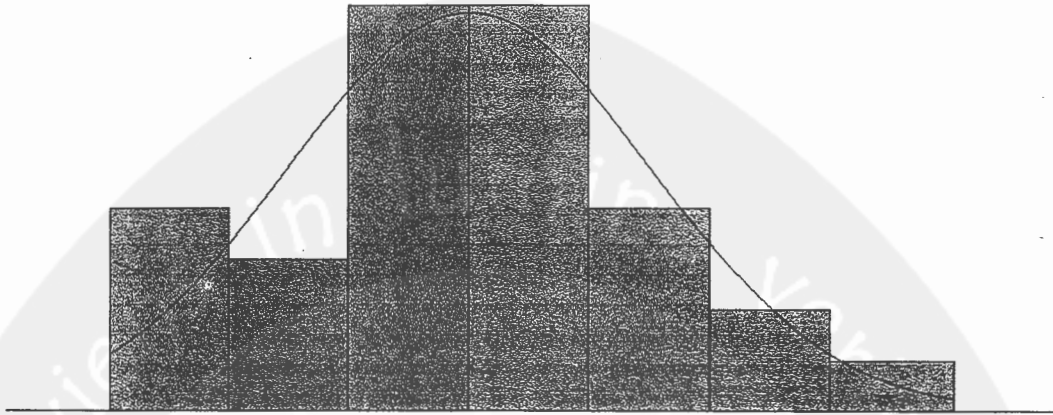

Distribution Summary

Distribution: Normal
 Expression: NORM(7.5, 1.52)
 Square Error: 0.009698

Data Summary

Number of Data Points = 30
 Min Data Value = 5
 Max Data Value = 11
 Sample Mean = 7.5
 Sample Std Dev = 1.55

Chi Square Test

Number of intervals = 4
 Degrees of freedom = 1
 Test Statistic = 0.287
 Corresponding p-value = 0.619

Histogram Summary

Histogram Range = 4.5 to 11.5
 Number of Intervals = 7



serviens in lumine veritatis

Lampiran B

Distribusi Data Proses

Machining

Distribusi Waktu Proses Frais 1

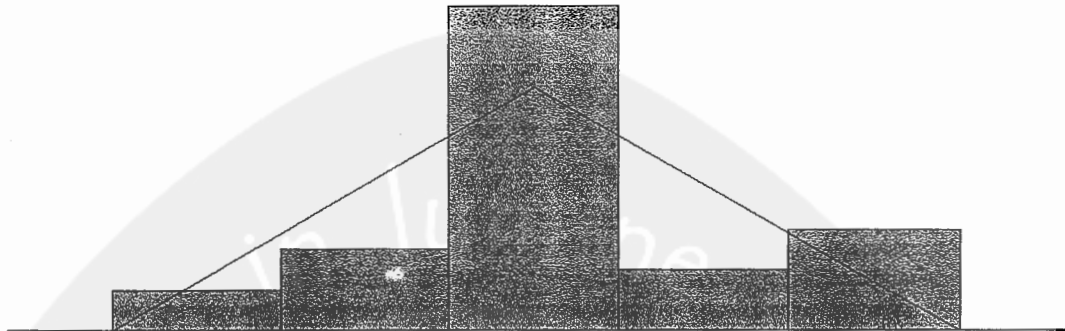

Distribution Summary
 Distribution: Triangular
 Expression: TRIA(4.18e+003,
 4.34e+003, 4.5e+003)

Square Error: 0.068711

Chi Square Test

Number of intervals = 3

Degrees of freedom = 1

Test Statistic = 6.57

Corresponding p-value
 = 0.0106

Kolmogorov-Smirnov Test

Test Statistic = 0.236

Corresponding p-value =
 0.0612

Data Summary

Number of Data Points = 30

Min Data Value = 4.18e+003

Max Data Value = 4.5e+003

Sample Mean = 4.34e+003

Sample Std Dev = 77.8

Histogram Summary

Histogram Range =
 4.18e+003 to 4.5e+003

Number of Intervals = 5

Distribusi Waktu Proses Frais 2

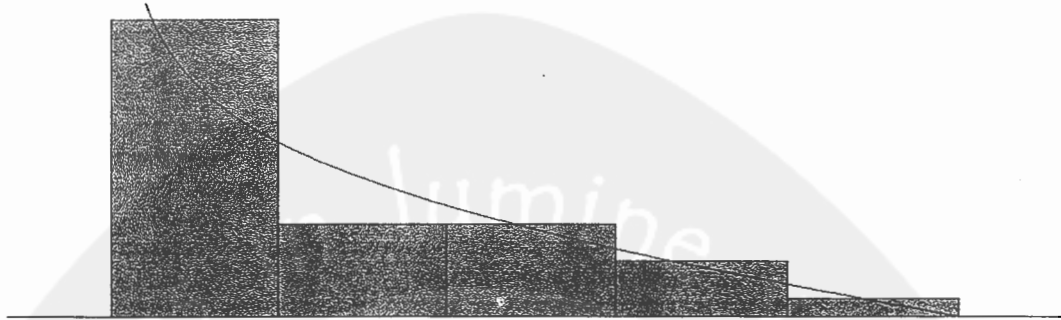

Distribution Summary
 Distribution: Beta
 Expression: $3.18e+003 + 588 * \text{BETA}(0.737, 1.94)$
 Square Error: 0.008206

Corresponding p-value=
 0.0966

Chi Square Test
 Number of intervals = 3
 Degrees of freedom = 0
 Test Statistic = 0.994
 Corresponding p-value <
 0.005

Data Summary
 Number of Data Points= 30
 Min Data Value = $3.18e+003$
 Max Data Value = $3.77e+003$
 Sample Mean = $3.34e+003$
 Sample Std Dev = 137

Kolmogorov-Smirnov Test
 Test Statistic = 0.22

Histogram Summary
 Histogram Range =
 $3.18e+003$ to $3.77e+003$
 Number of Intervals = 5

Distribusi Waktu Proses Marking

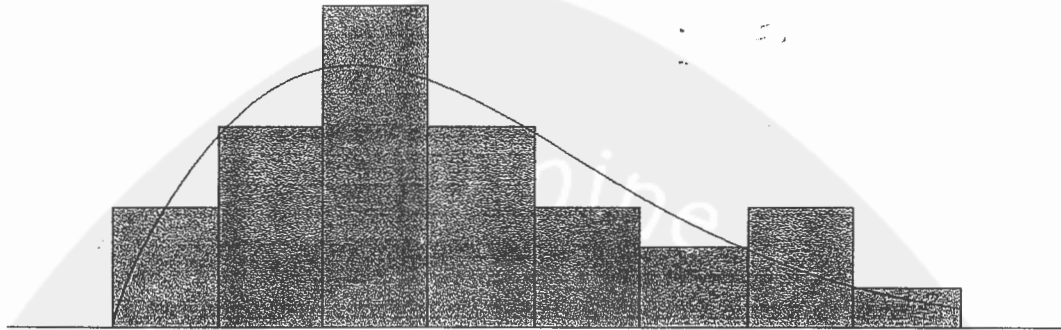

Distribution Summary

Distribution: Weibull
Expression: $15.5 +$
WEIB(3.67, 1.78)
Square Error: 0.008162

Data Summary

Number of Data Points = 30
Min Data Value = 16
Max Data Value = 23
Sample Mean = 18.8
Sample Std Dev = 1.92

Chi Square Test

Number of intervals = 4
Degrees of freedom = 1
Test Statistic = 0.885
Corresponding p-value =
0.376

Histogram Summary

Histogram Range = 15.5
to 23.5
Number of Intervals = 8

Distribusi Waktu Proses Slep Kedua Sisi

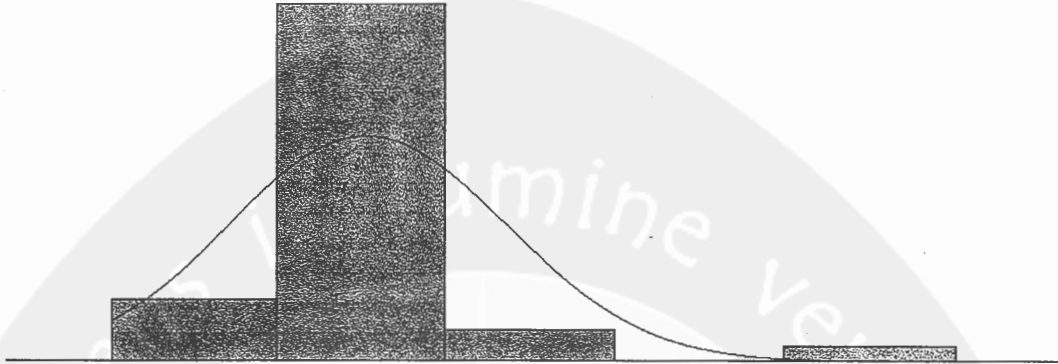

Distribution Summary Corresponding p-value =
 Distribution: Normal 0.0373

Expression: NORM(1.45e+003,
 106)

Square Error: 0.140609

Data Summary

Number of Data Points = 30

Min Data Value = 1.25e+003

Max Data Value = 1.89e+003

Sample Mean = 1.45e+003

Sample Std Dev = 108

Chi Square Test

Number of intervals = 3

Degrees of freedom = 0

Test Statistic = 15.1

Corresponding p-value <

0.005

Histogram Summary

Histogram Range =

1.25e+003 to 1.89e+003

Number of Intervals = 5

Kolmogorov-Smirnov Test

Test Statistic = 0.253

Distribusi Waktu Proses Vernis

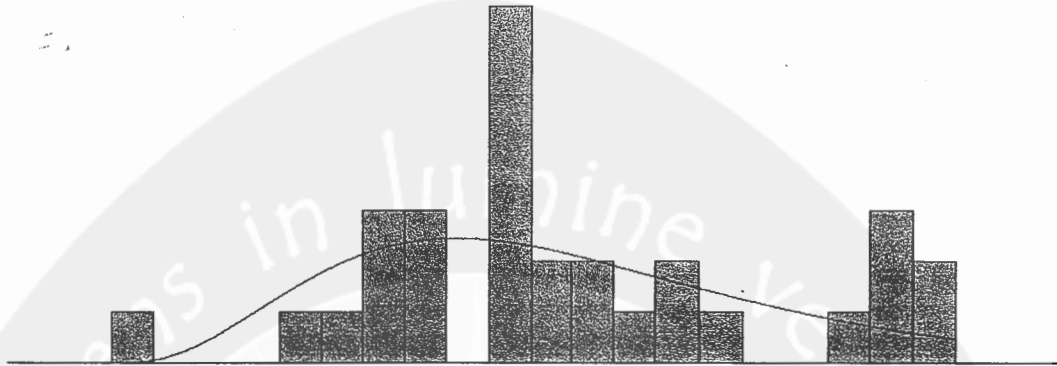

Distribution Summary

Distribution: Erlang
 Expression: $20.5 +$
 ERLA(2.74, 4)
 Square Error: 0.047713

Data Summary

Number of Data Points = 30
 Min Data Value = 21
 Max Data Value = 40
 Sample Mean = 31.5
 Sample Std Dev = 4.84

Chi Square Test

Number of intervals = 4
 Degrees of freedom = 1
 Test Statistic = 4.87
 Corresponding p-value =
 0.0283

Histogram Summary

Histogram Range = 20.5
 to 40.5
 Number of Intervals = 20

Distribusi Waktu Proses Inspeksi

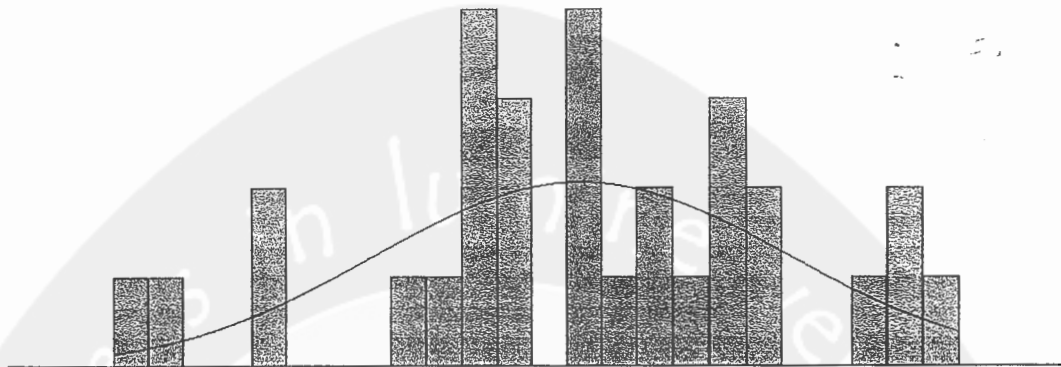

Distribution Summary

Distribution: Normal
 Expression: NORM(29.9, 5.79)
 Square Error: 0.032998

Data Summary

Number of Data Points = 30
 Min Data Value = 17
 Max Data Value = 40
 Sample Mean = 29.9
 Sample Std Dev = 5.89

Chi Square Test

Number of intervals = 5
 Degrees of freedom = 2
 Test Statistic = 1.9
 Corresponding p-value = 0.407

Histogram Summary

Histogram Range = 16.5
 to 40.5
 Number of Intervals = 24



serviens in lumine veritatis

Lampiran C

**Surat Keterangan Kerja
Praktek**



PT. PINDAD (PERSERO)

No. : Sket / 531 / P / BD/ VIII / 2009

Surat Keterangan

Menerangkan bahwa :

Nama : *Berardus Budhi Hufiantoro*
Tempat / Tanggal Lahir : *Jogyakarta, 16 Januari 1987*
No. Induk / NIRM : *060605063*
Sekolah / Universitas : *Universitas Atmajaya Yogya*

Telah Melaksanakan

Praktek Kerja Industri / Penelitian di PT. Pindad (Persero) Bandung

Pada bidang Teknik Industri mulai tanggal 01 Juni 2009 sampai dengan tanggal 01 Agustus 2009
Keterangan ini di buat untuk dipergunakan sebagaimana mestinya.

Dikeluarkan di : **B a n d u n g**
Pada tanggal : **01 Agustus 2009**



PT. PINDAD (PERSERO)
A.n. DEPUTI DIREKTUR PENGEMBANGAN
SUMBER DAYA DITRENBANG
[Signature]
P. K. LASMAN TAMPUBOLON, MBA
KADepdiklat DITRENBANG

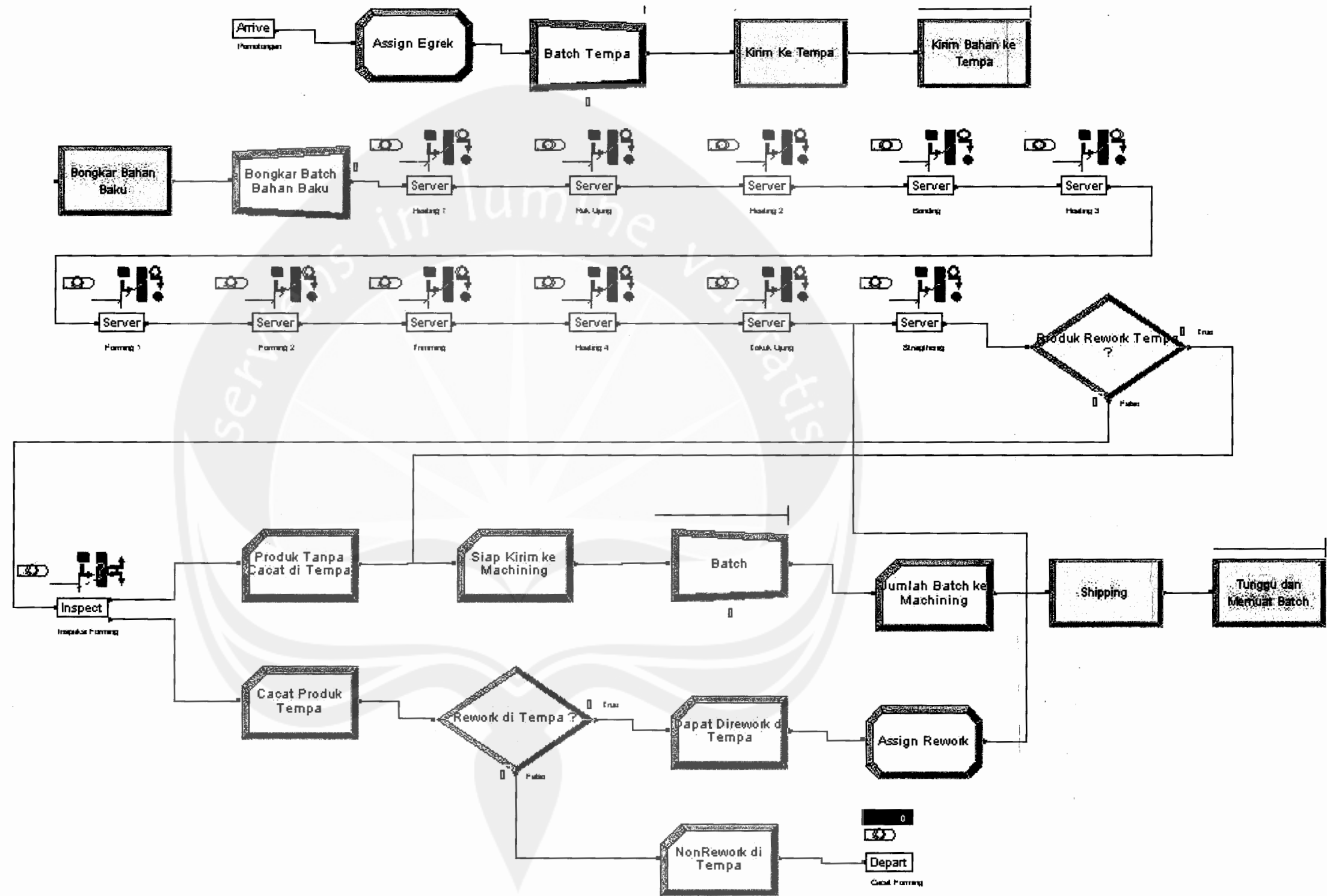

Gambar 5.1. Model Proses Tempa di ARENA 7.01

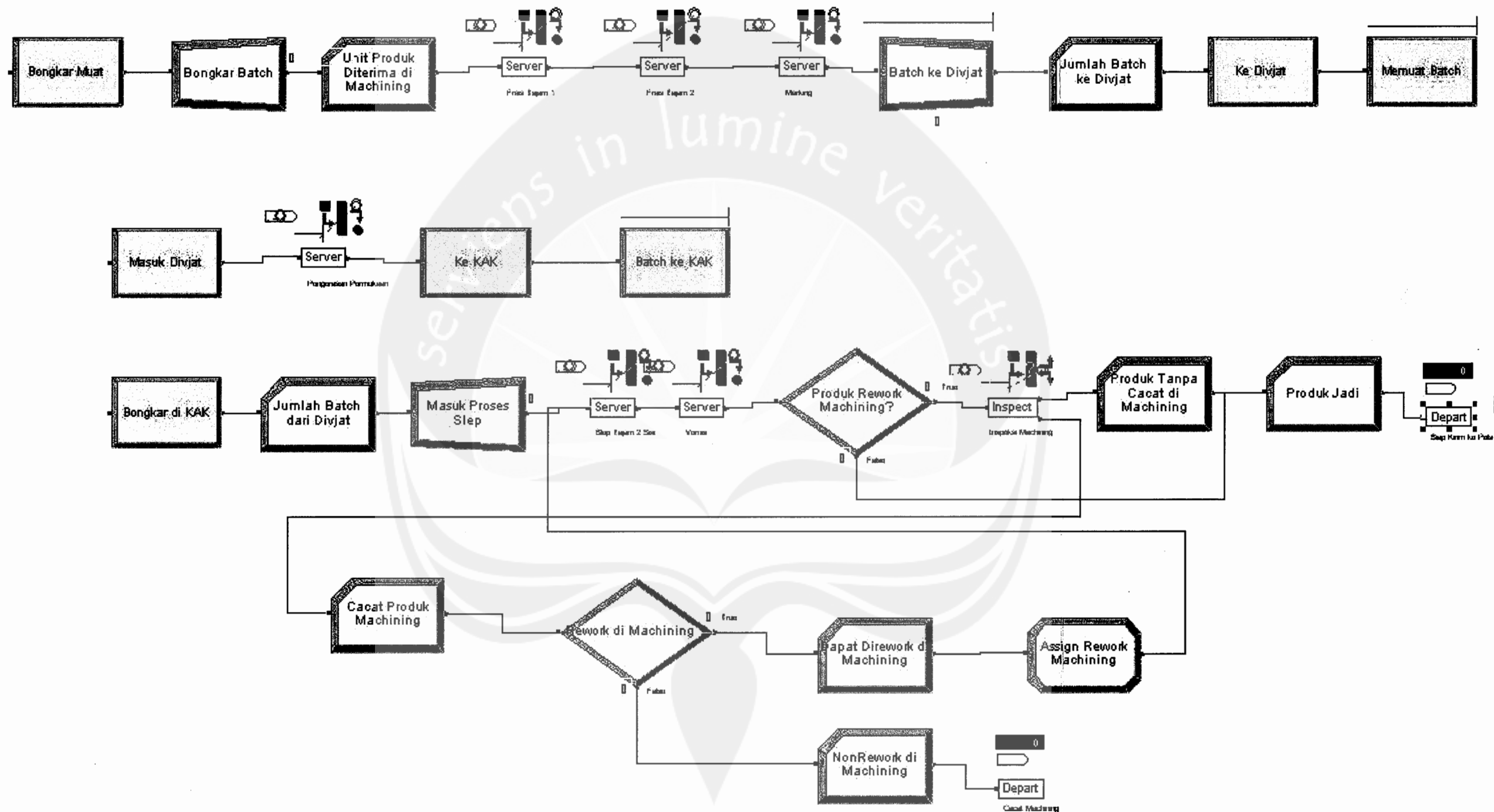

Gambar 5.2. Model Proses Machining di ARENA 7.01

Sedang

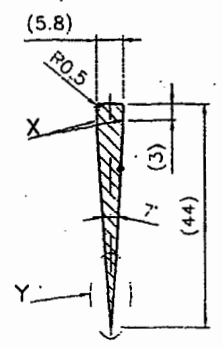
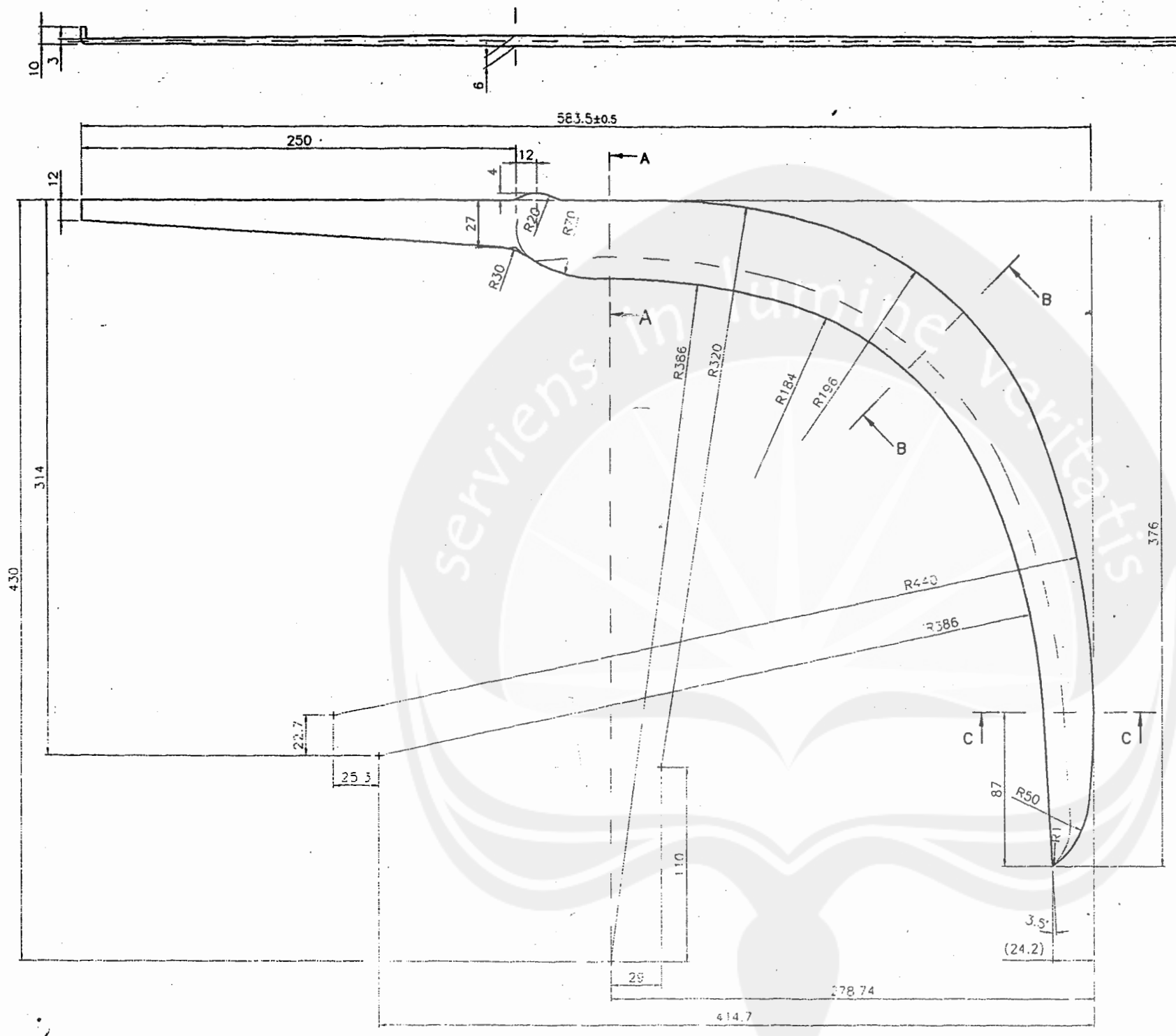

POT. A-A (SKALA 1:1)

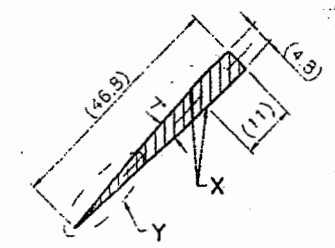

POT. B-B (SKALA 1:1)

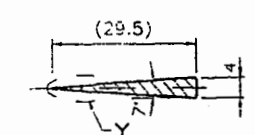

POT. C-C (SKALA 1:1)

CATATAN :
 Kekerasan badan pisau 30 - 35 Hrc.
 Kekerasan mata pisau 50 - 55 Hrc.

*) Ukuran sebelum diasah
 X : Pembuangan sudut (grinding), sisa proses milling
 Y : Asah tajam (grinding)

PENJ.MERK TN :
 TINGGI HURUF 9
 KEDALAMAN LEKUKAN 0.5
 TEBAL GARIS HURUF 1

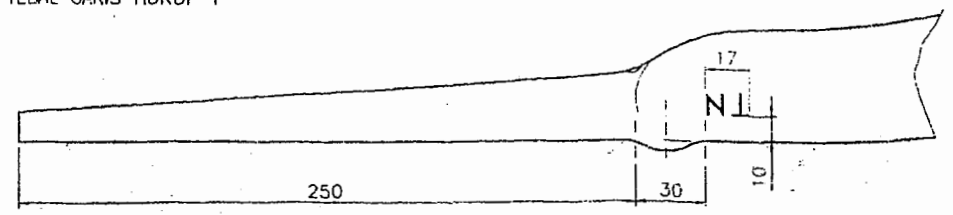

Nomor Bagian	NAMA BAGIAN	Jmlh.	BAHAN & SPEC.	KETERANGAN
-	-	-	SUP.9 Ø20	
	NAMA : E G R E K (FINISHING)		Skala: 1:2 Satuan: mm	Digambar: 29.05.09
				Diperiksa:
PT PINDAD (PERSERO) DIVISI TEMPA DAN COR			Nomor Induk Gambar : F.06-09/P	Nomor Gambar : F.062-09/P