

1	Base plate	1			
Pieces	Description	Item	Material	Dimension	Remarks
Revision Index		Drawn by : Galih		Scale : 1:1	
		Reg. Nr. : 101606381		Unit : mm	
		Date : 11102011		Material : SS41	
		Checked by : Wisnu		Sign. :	
		A4	MESIN VACUUM THERMOFORMING OTOMATIS		
INDUSTRIAL ENGINEERING UAJY				Operation	Cut Drill
Dwg. Nr. 1201		Origin.		Rep.	Rep.by.
Sn.		Ns.			

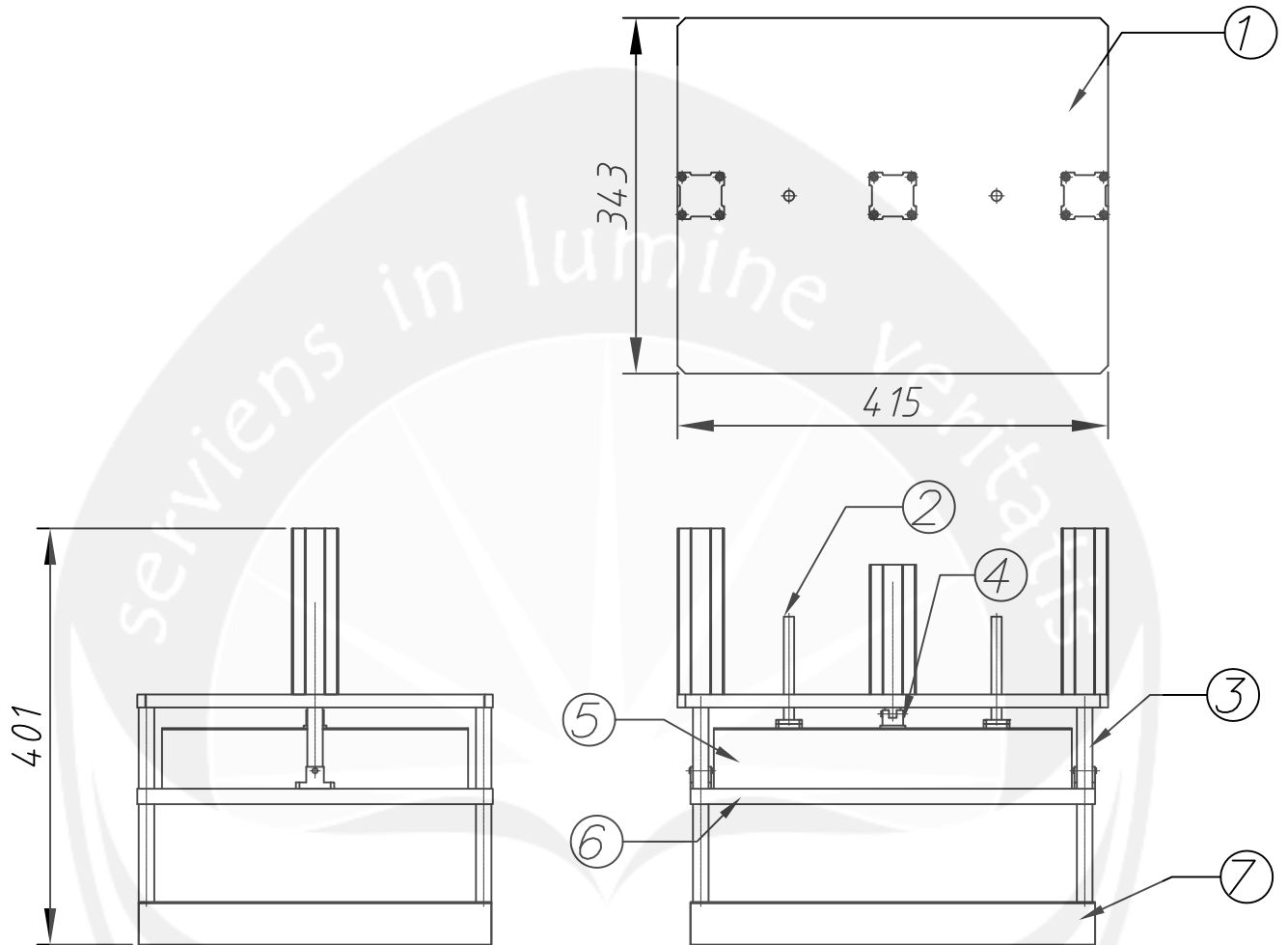

Sub Assy 2 (Heater Unit)					
Pieces	Description	Item	Material	Dimension	Remarks
Revision Index		Drawn by : Galih		Scale : 1:1	
		Reg. Nr. : 101606381		Unit : mm	
		Date : 11102011		Material :	
		Checked by : Wisnu		Sign. :	
		A4	MESIN PEMOTONG LEMBARAN PLASTIK		
INDUSTRIAL ENGINEERING UAJY				Operation Cut Drill	Dwg. Nr. 1200
Origin.	Rep.	Rep.by.		Sn. Ns.	

Item 6
Qty 2 pcs

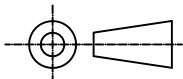
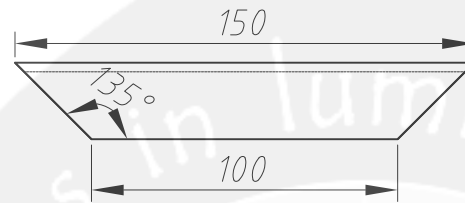

Item 8
Qty 2 pcs

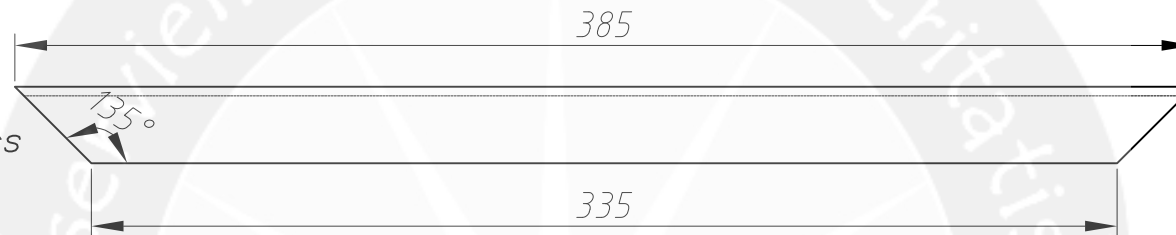

Item 9
Qty 3 pcs

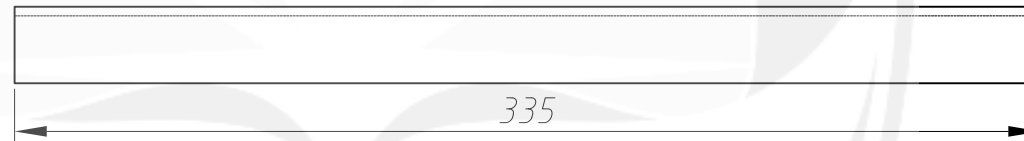

Note :
All Item 6,8,9 profile U
material same

Pieces	Frame	Item	Material	Dimension	Remarks
Revision Index		Drawn by : Galih		Scale : 1:1	
		Reg. Nr. : 101606381		Unit : mm	
		Date : 11102011		Material :	
		Checked by : Wisnu		Sign. :	
		A4	MESIN VACUUM THERMOFORMING OTOMATIS		
INDUSTRIAL ENGINEERING UAJY				Operation	Cutting
Dwg. Nr.		Origin.		Rep. by.	
Sn.		Rep.		Ns.	

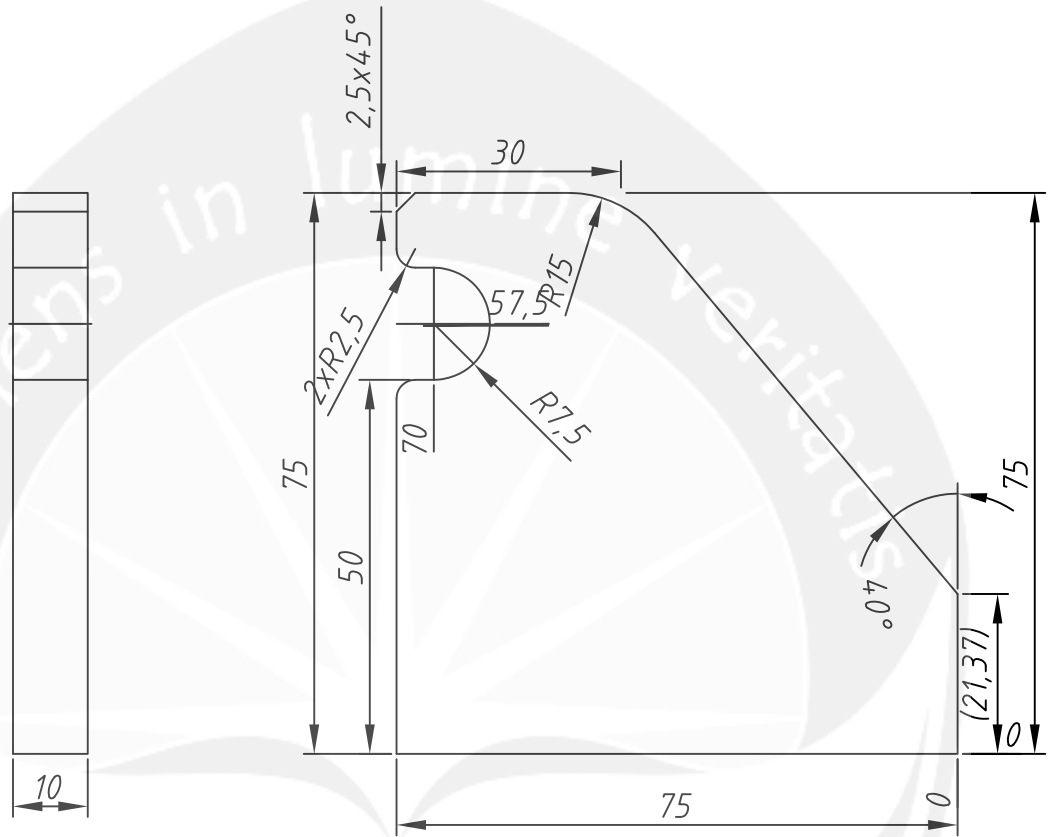

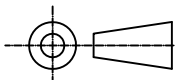
2	Frame	5			
Pieces	Description	Item	Material	Dimension	Remarks
Revision Index		Drawn by : Galih		Scale : 1:1	
		Reg. Nr. : 101606381		Unit : mm	
		Date : 11102011		Material : SS41	
		Checked by : Wisnu		Sign. :	
		A4	MESIN VACUUM THERMOFORMING OTOMATIS		
INDUSTRIAL ENGINEERING UAJY				Operation Cutting	Dwg. Nr. 1105
Origin.	Rep.	Rep.by.	Sn.		Ns.

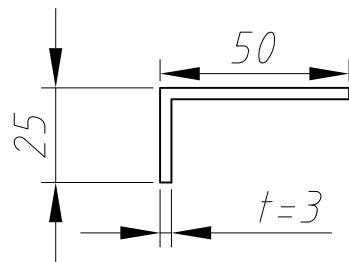

2	profil L	4	profil L		
Pieces	Description	Item	Material	Dimension	Remarks
Revision Index		Drawn by : Galih		Scale : 1:1	
		Reg. Nr. : 101606381		Unit : mm	
		Date : 11102011		Material : profil L	
		Checked by : Wisnu		Sign. :	
		A4	MESIN VACUUM THERMOFORMING OTOMATIS		
INDUSTRIAL ENGINEERING UAJY				Operation Cut Drill	Dwg. Nr. 1104
Origin.		Rep.		Rep.by.	Sn. Ns.

Item 1
Qty 2 pcs



Item 2
Qty 4 pcs

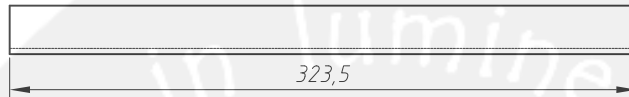

Item 3
Qty 2 pcs

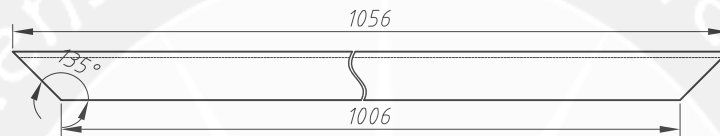

Item 7
Qty 2 pcs

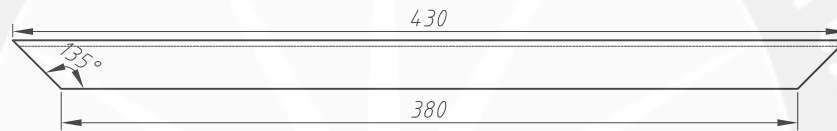

Note :
All Item 1,2,3,&7 profile U
material same

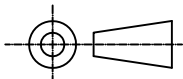
Pieces	Description	Item	Material	Dimension	Remarks
Revision Index		Drawn by : Galih		Scale : 1:1	
		Reg. Nr. : 101606381		Unit : mm	
		Date : 11102011		Material : profil U	
		Checked by : Wisnu		Sign. :	
		A4	MESIN VACUUM THERMOFORMING OTOMATIS		
INDUSTRIAL ENGINEERING UAJY				Operation Cutting	Dwg. Nr.
Origin.	Rep.	Rep.by.		Sn. Ns.	

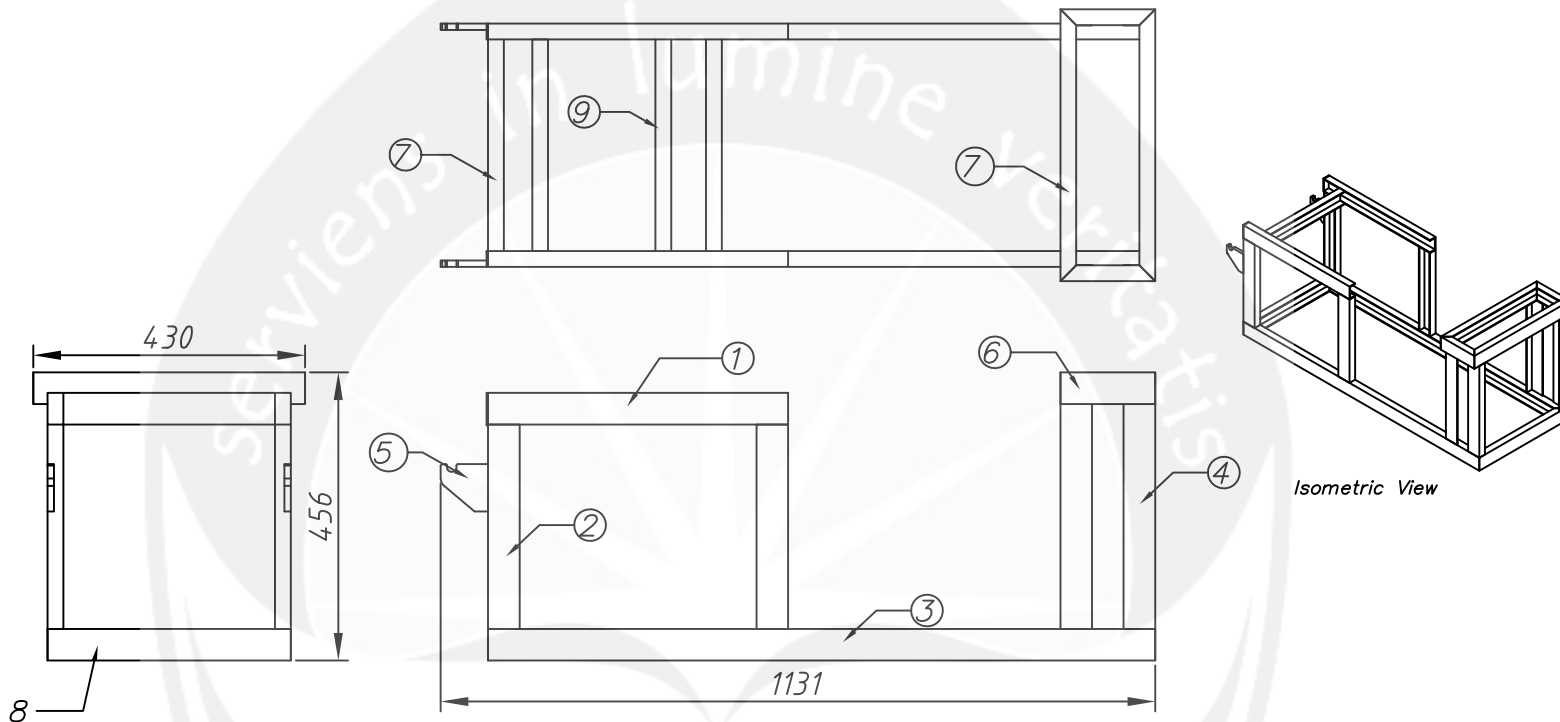

Sub Assy 1 (Main frame)						
Pieces	Description	Item	Material	Dimension	Remarks	
Revision Index		Drawn by : Galih		Scale : 1:1		
		Reg. Nr. : 101606381		Unit : mm		
		Date : 11102011		Material : profil U		
		Checked by : Wisnu		Sign. :		
		A4	MESIN VACUUM THERMOFORMING OTOMATIS			
INDUSTRIAL ENGINEERING UAJY				Operation	Cutting Welding	Dwg. Nr. 1100
Origin.	Rep.	Rep.by.	Sn.	Ns.		

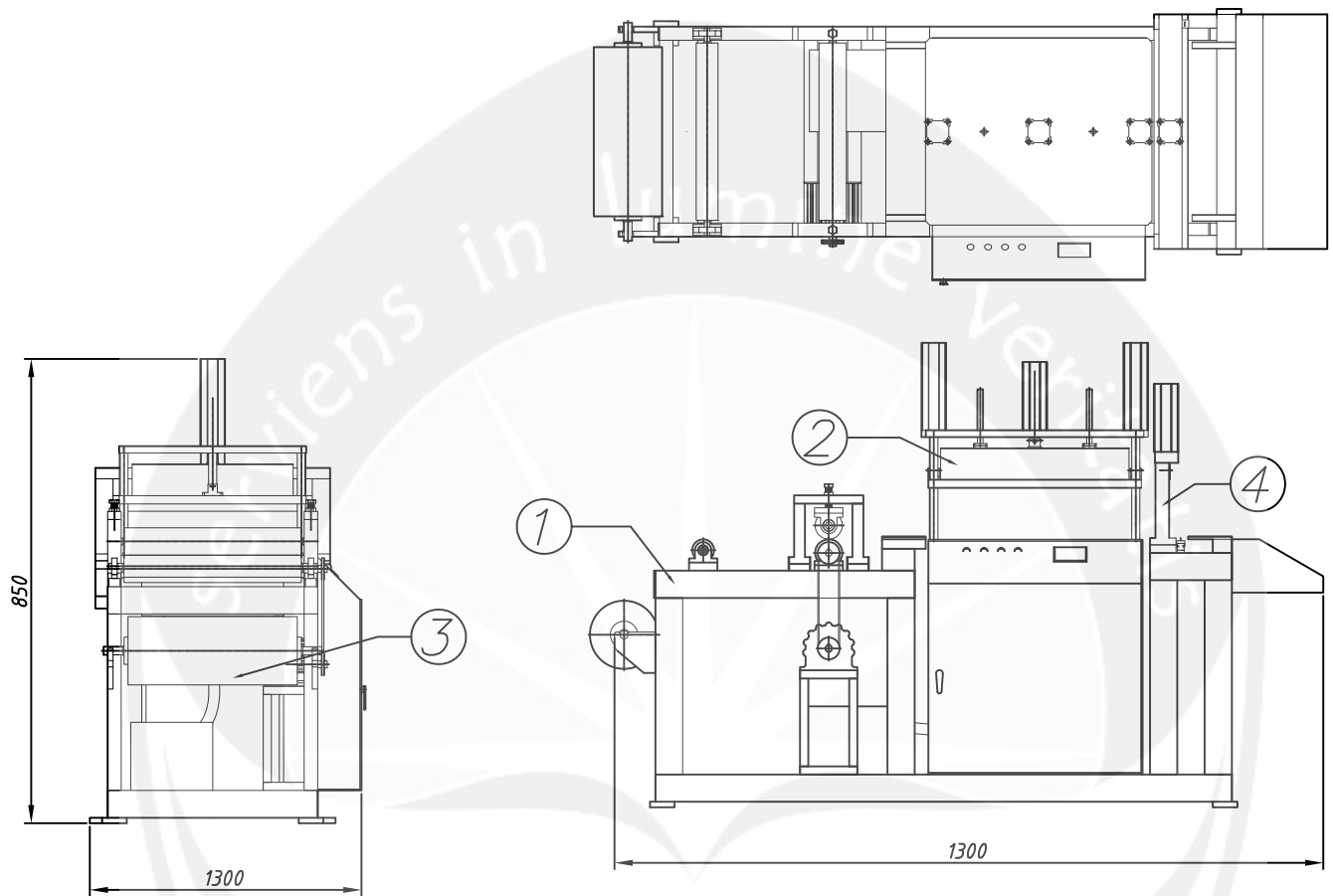

	Sub Assy 1 (Main Frame)	1			1100	
	Sub Assy 2 (Heater Unit)	2			1200	
	Sub Assy 3 (Vacuum Unit)	3			1300	
	Sub Assy 4 (Cutter Unit)	4			1400	
Pieces	Description	Item	Material	Dimension	Remarks	
Revision Index		Drawn by : Galih		Scale : 1:1		
		Reg. Nr. : 101606381		Unit : mm		
		Date : 11102011		Material :		
		Checked by : Wisnu		Sign. :		
		A4	MESIN VACUUM THERMOFORMING OTOMATIS			
INDUSTRIAL ENGINEERING UAJY				Operation		Dwg. Nr. 1000
Origin.	Rep.	Rep.by.		Sn. Ns.		